

PRODUCT DATA DRAWING

REVISION HISTORY			
REV	DESCRIPTION	DATE	APPROVED
-	REL. DCN 39275	08/09/12	STW

EXPIRED

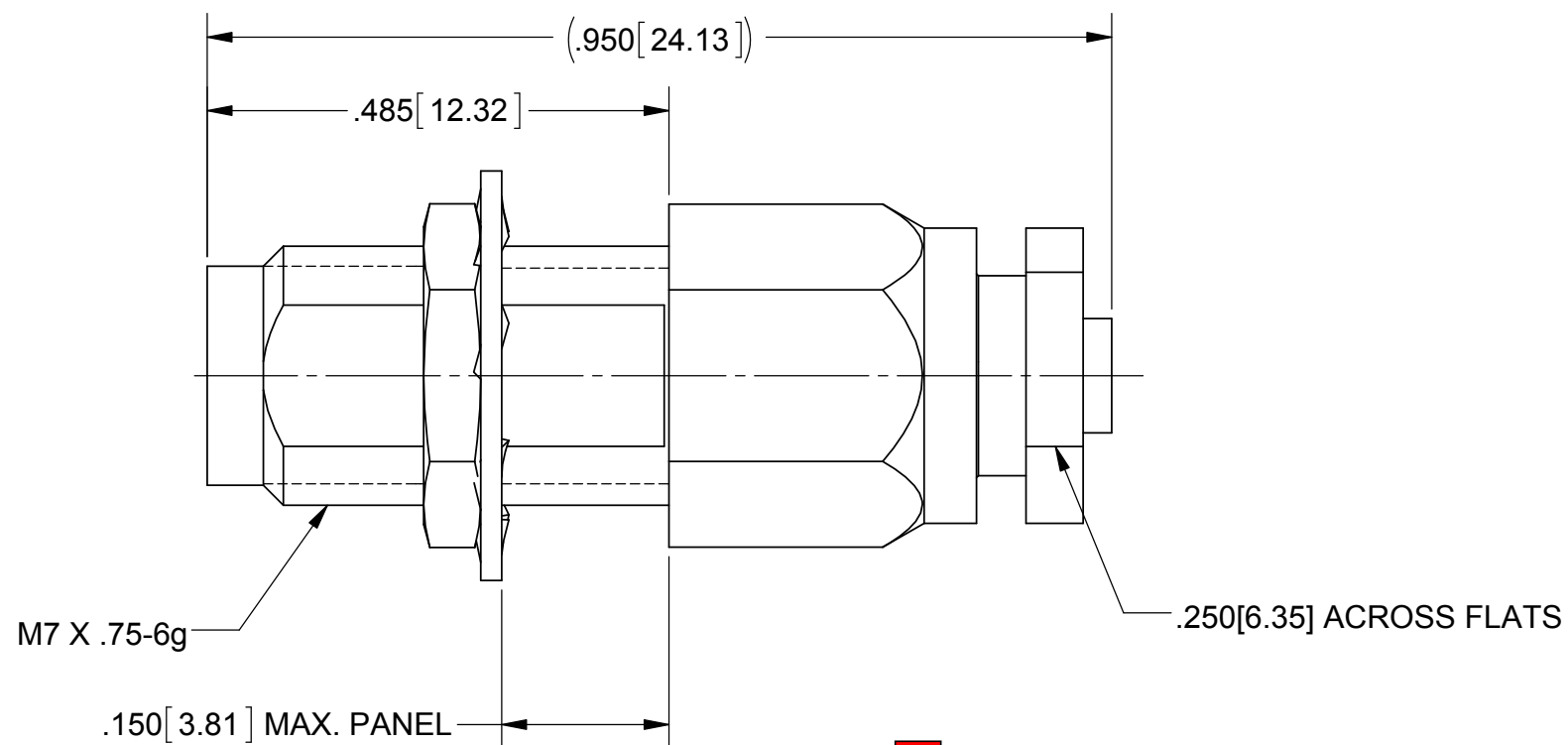
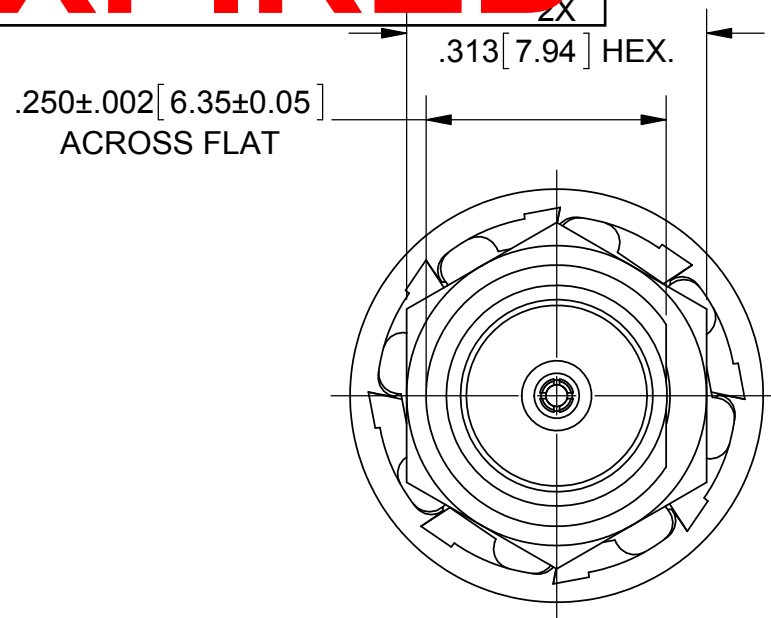

- MATERIAL:**
 BODY, HEX NUT, FERRULE, CLAMP NUT, INSERTS & SLEEVES: STAINLESS STEEL PER AMS-5640, ALLOY UNS S30300, TYPE 1
- CONTACT:**
 BERYLLIUM COPPER PER ASTM B196, ALLOY No. UNS C17300, TD04
- LOCKWASHER:**
 STAINLESS STEEL 300 SERIES
- INSULATOR:**
 PCTFE PER ASTM D1430
- FINISH:**
 BODY, HEX NUT, CLAMP NUT, INSERTS & SLEEVES: PASSIVATED PER AMS-2700.
- FERRULE & CONTACT:**
 GOLD PER ASTM B488, TYPE II, CODE C, CLASS 1.27, OVER NICKEL PER AMS-QQ-N-290, CLASS 1, .000050" MIN.

- PERFORMANCE:**
- IMPEDANCE: 50 OHMS
 FREQ. RANGE: DC TO 65.0 GHz
 VSWR: 1.33:1 DC TO 65.0 GHz
 INSERTION LOSS: .03 X SQRT(F(F IN GHz))
 DWV: 500 VRMS
 OPERATING TEMP.: -55°C TO +125°C

ENGAGEMENT/
 DISENGAGEMENT: 2 IN-LBS

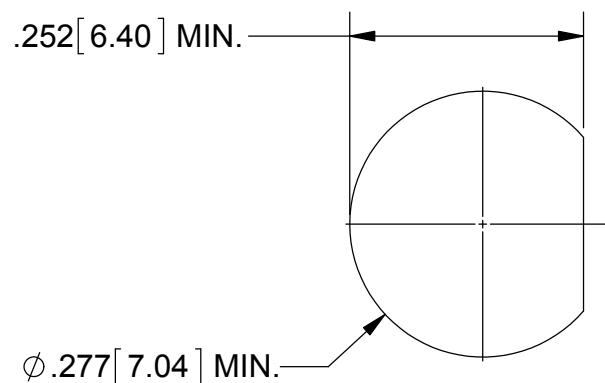

RECOMMENDED MOUNTING HOLE

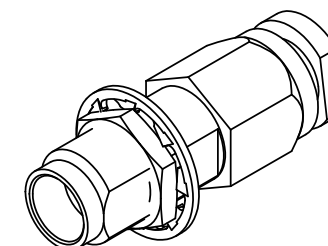

MATERIAL: SEE NOTES	DIMENSIONS ARE IN INCHES TOLERANCES: FRACTIONAL: ±1/64 ANGULAR: X° ±1'0" X'X' ±15'	UNLESS OTHERWISE SPECIFIED 1) ALL DIMENSIONS ARE IN INCHES (MILLIMETERS) 2) ALL DIMENSIONS ARE AFTER PLATING. 3) BREAK CORNERS & EDGES .005 R. MAX. 4) CHAM. 1ST & LAST THREADS. 5) SURFACE ROUGHNESS 63-MIL-STD-10. 6) DIA.'S ON COMMON CENTERS TO BE CONCENTRIC WITHIN .005 T.I.R. 7) REMOVE ALL BURRS	SV Microwave, Inc. 2400 Centrepark West Drive, Suite 100 West Palm Beach, FL 33409
FINISH: SEE NOTES	DECIMAL: .X ±.030 .XX ±.010 .XXX ±.005	INTERPRET DIMENSIONS AND TOLERANCES PER ASME Y14.5M - 1994	TITLE: 1.85MM JACK, BULKHEAD MT. FOR Ø .085 CABLE
SURFACE AREA: N/A	THIRD ANGLE PROJECTION	DRAWN: JMC 08/08/12	SIZE: B CAGE CODE: 95077 DWG. NO. SF3321-60007
PROPRIETARY THE INFORMATION CONTAINED IN THIS DRAWING IS THE SOLE PROPERTY OF SV MICROWAVE, INC. ANY REPRODUCTION IN PART OR AS A WHOLE WITHOUT THE WRITTEN PERMISSION OF SV MICROWAVE, INC IS PROHIBITED.		CHECKED: STW 08/09/12	SCALE: 5:1
		APPROVED: STW 08/09/12	SHEET 1 OF 1