

**BLOCK SD CONNECTOR**

**1. PURPOSE 目的**

Define the packaging specification and packaging method of BLOCK SD CONNECTOR.

订定 BLOCK SIM AND SD CONNECTOR 产品之包装规格及包装方式。

**2. APPLICABLE PRODUCT 适用范围**

Product Part No.	Description
2286981-1	BLOCK SD CONNECTOR(P14-CSSH-029)
2287217-1	BLOCK SIM CONNECTOR SIDE ENTRY

**3. PACKAGING MATERIAL 包装材料**

Package	Part No.	Description	Usage	
			2286981-1	2287217-1
INNER	1533558-1	EMBOSS TAPE(24W)	36.72 MR/3000	-
	1533566-1	EMBOSS TAPE(16W)	-	36.72 MR/3000
	(1533128-3)	REEL, PLASTIC(W16.4 X D330)	-	1/3000
	1-1533127-6	COVER TAPE(13.3mm)	-	40.0 MR/3000
	(1-1533128-4)	REEL, PLASTIC(W24.4 X D330)	1/3000	-
	2-1533127-4	COVER TAPE(21.3mm)	40.0 MR/3000	-
	623865-4	INNER LABEL	1/3000	1/3000
MIDDLE	1533282-5	PE BAG(457x407)	1/3000	1/3000
	1-623124-0	DESICCANT(10g)	2/3000	2/3000
	623880-7	Air bag	1/3000	1/3000
OUTER	2-1533040-7	SHIPPING BOX(380X380X200)	1/12000	1/15000
	8-912066-8	AIR CAP	2/12000	2/15000
	623897-6	PAPER PAD, FOLDER	4/12000	4/15000
	1-623865-7	OUTER LABEL	1/12000	1/15000

	Inner	Middle	Outer
LABEL	623865-4	-	1-623865-7
SEALING	Tape	-	Tape

**4. PACKAGING QUANTITY 包装数量**

PN	Inner	Middle	Outer
2286981-1	3000 pcs/reel	1 reel/bag	3000 X 4 bags = 12000 pcs/box
2287217-1	3000 pcs/reel	1 reel/bag	3000 X 5 bags = 15000 pcs/box

DR <b>Sam Wu</b>	CHK <b>Prince Lee</b>	APVD <b>Ansin Yang</b>
---------------------	--------------------------	---------------------------

## 5. PACKING METHOD 包装方法

5.1. Place one plastic reel on machine.

将一个塑料盘安装在收料器上。

5.2. Reel one circle of cover tape & 160 min.(at least 40 pockets) of empty carrier sealed with cover tape onto reel core.

Note: Cover tape stick method must be thermo-compression bonding type

在卷盘的中心先卷一圈胶布，然后再空最少300MM(40个空pocket)的编带和胶布(COVER TPAE 为热封方式)。

5.3. Inner packaging specification will be fixed based on action packing machine's operation.

内包装的方法依照机器的运作来操作。

**注： 1、当达到包装数量，再让其空走完剩余的编带和胶布，但至少不得少于40个空pocket，然后再绕一圈胶布。**

**2、包装方法(产品放入Carrier Tape 的方向及包好后产品引出的方向)请严格参照成品图纸。**

5.4. Stick the end of cover tape.

用皱纹纸贴住胶布末端(注：在皱纹纸的尾端反贴大约长10mm)。

5.5. Take off the plastic reel, then Place an inner label on the reel full of products..

取下塑料盘放好，然后在卷盘一侧贴一内标签（产品拉出时面向操作员一侧）。

5.7. Load 1 reels with products & two bags of dessciant into bag and heat seal it.

将1卷装好产品的卷盘和两袋干燥剂放入袋子中并用热封好袋口。

**注：贴有标签的一面朝上。**

5.8. Place one reel into air cap bag and secure the bag opening with adhensive tape.

将已包装好的一卷盘产品放气泡袋中，并用透明封箱胶带封住袋口。

5.9. Set up a box and secure bottom flaps with tape.

折叠好一包装箱，并用胶带封住箱的底部。

5.10. Set up and seal paper cushion with tape and put four paper cushiones in the coner of box.

折叠并用胶带贴好纸护角，将纸护角置于箱内四角处。

### **Only for 2286981-1:**

5.11.1. Wrap 4 bags of product with two pieces of air cap (8-912066-8) and place it into the box.

用两块气泡垫(8-912066-8) 十字交叉地将4卷产品裹包好，然后放入箱中，气泡朝外。

### **Only for 2287217-1:**

5.11.2. Wrap 5 bags of product with two pieces of air cap (8-912066-8) and place it into the box.

用两块气泡垫(8-912066-8) 十字交叉地将5卷产品裹包好，然后放入箱中，气泡朝外。

## 5. PACKING METHOD 包装方法

5.12. Seal the box with tape. And place product identification label in "product id" marked on box.  
 用胶带封箱，在箱外印有“PRODUCT ID”标识处贴上外标签。

## 6. PACKAGING ILLUSTRATION 包装示意图

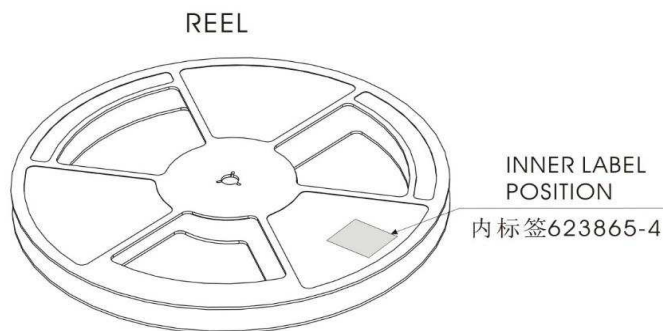
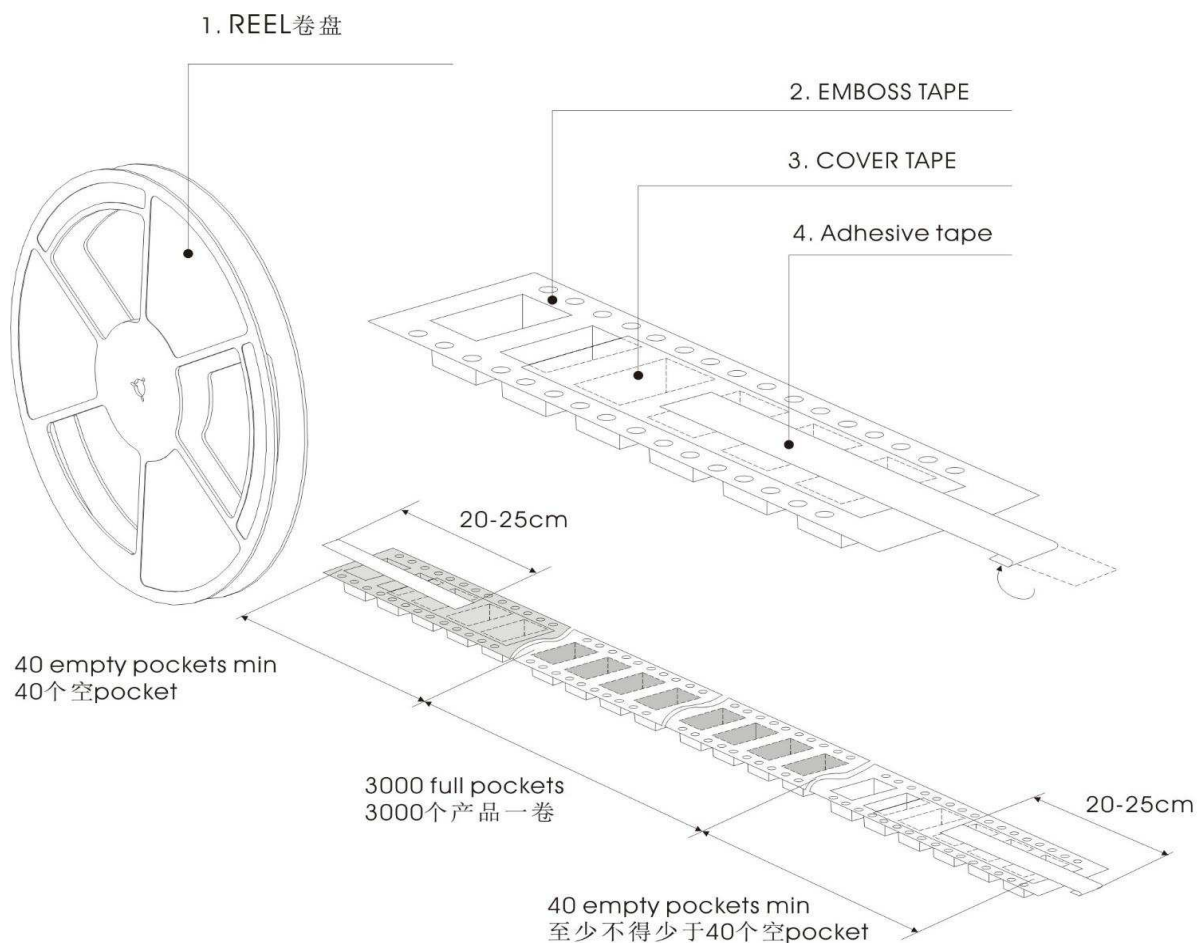

NB: put the label only on one side of the reel  
 在卷盘一侧贴一内标签

6. PACKAGING ILLUSTRATION 包装示意图

