

Package: QFN, 16-Pin, 3 mm x 3 mm



### Product Description

The RFFC0085 is a downconverter designed to be used as an Out-of-Band Tuner for use in CATV set-top box and Digital Cable Ready TV applications. The RFFC0085 consists of an input AGC amplifier, mixer, and a video/AGC amplifier. This device offers optimum performance with low power consumption and low distortion. This product is RoHS compliant.

### Features

- 3.3V Single Supply Operation
- Low Power Consumption (345 mW)
- Low Distortion: -53dBc at 1V<sub>pp</sub>
- 77 dB Total Conversion Gain
- 55 dB Total Gain Control Range
- Low LO-RF Leakage

### Applications

- Cable Set-Top Boxes
- Digital Cable Ready Televisions

**Optimum Technology Matching® Applied**

- GaAs HBT
- GaAs MESFET
- InGaP HBT
- SiGe BiCMOS
- Si BiCMOS
- SiGe HBT
- GaAs pHEMT
- Si CMOS
- Si BJT
- GaN HEMT
- InP HBT
- RF MEMS
- LDMOS

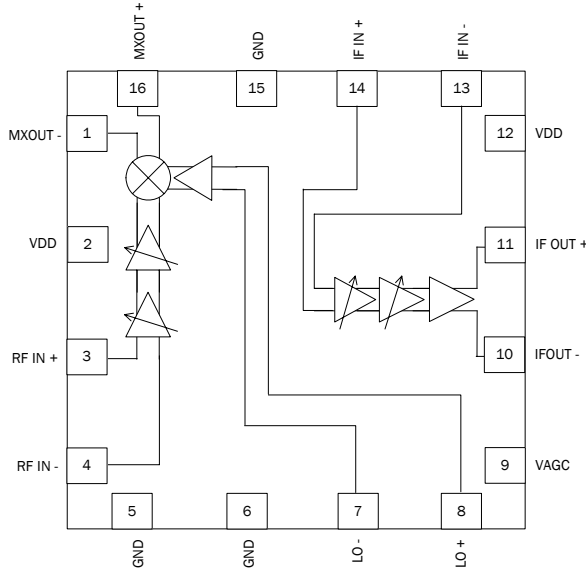

Parameter	Specification			Unit	Condition
	Min.	Typ.	Max.		
RF Input Frequency Range	50		150	MHz	High Side LO
LO Input Frequency Range	80		220	MHz	High Side LO
Maximum Conversion Gain		77		dB	Includes saw filter loss at V <sub>AGC</sub> =3.0V
AGC Voltage	0		3	V	
AGC Dynamic Range	50	55		dB	V <sub>AGC</sub> =0V to 3.0V
Third Order Intermodulation	53	60		dBc	1V <sub>pp</sub> Differential Output, 1kΩ load
IF Output Level		1	2	V <sub>pp</sub>	Differential Output, 1kΩ load
Noise Figure		15	16.5	dB	V <sub>AGC</sub> =3.0V
LO Leakage at the RF Port			-87	dB	
Supply Voltage	3.0	3.3	3.6	V	
Supply Current		106	123	mA	V <sub>AGC</sub> =3.0V
		104	123	mA	V <sub>AGC</sub> =0.0V

Test Conditions: T<sub>A</sub> = 25 °C, V<sub>DD</sub> = 3.3V, unless otherwise specified

## Absolute Maximum Ratings

Parameter	Rating	Unit
Supply Voltage ( $V_{DD}$ )	-0.3 to +3.6	V
Operating Temperature ( $T_{OP}$ )	-40 to +85	°C
Storage Temperature ( $T_{STG}$ )	-65 to +150	°C
Junction Temperature ( $T_j$ )	99	°C
RF Input ( $V_{AGC}=0V_{DC}$ ) for an IF OUT=1V <sub>P-P</sub>	30	dBmV
RF Input ( $V_{AGC}=3V_{DC}$ ) for an IF OUT=1V <sub>P-P</sub>	-24	dBmV



Caution! ESD sensitive device.

Exceeding any one or a combination of the Absolute Maximum Rating conditions may cause permanent damage to the device. Extended application of Absolute Maximum Rating conditions to the device may reduce device reliability. Specified typical performance or functional operation of the device under Absolute Maximum Rating conditions is not implied.

RoHS status based on EU Directive 2002/95/EC (at time of this document revision).

The information in this publication is believed to be accurate and reliable. However, no responsibility is assumed by RF Micro Devices, Inc. ("RFMD") for its use, nor for any infringement of patents, or other rights of third parties, resulting from its use. No license is granted by implication or otherwise under any patent or patent rights of RFMD. RFMD reserves the right to change component circuitry, recommended application circuitry and specifications at any time without prior notice.

Operation of this device beyond any one of these limits may cause permanent damage. For reliable continuous operation, the device voltage and current must not exceed the maximum operating values specified in the table on page one.

## Typical Performance Curves

Conversion Gain versus RF

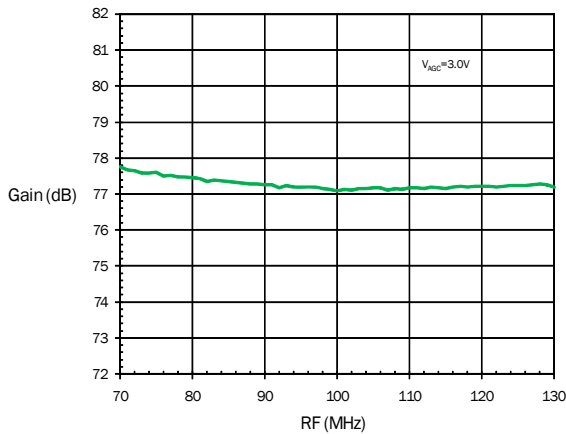

IF Output versus Frequency

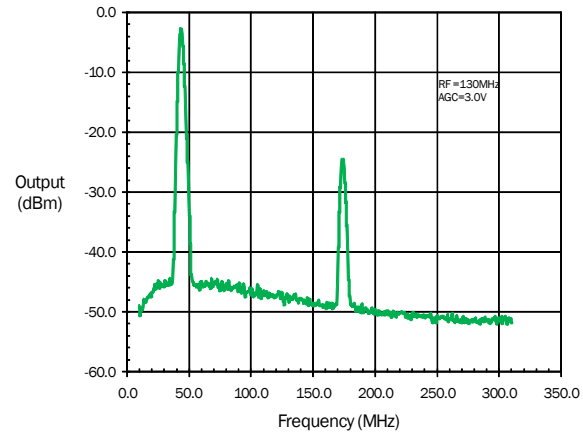

Conversion Gain versus AGC

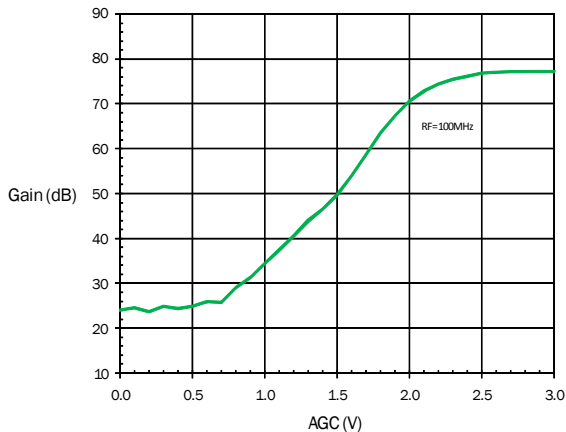

Noise Figure versus AGC

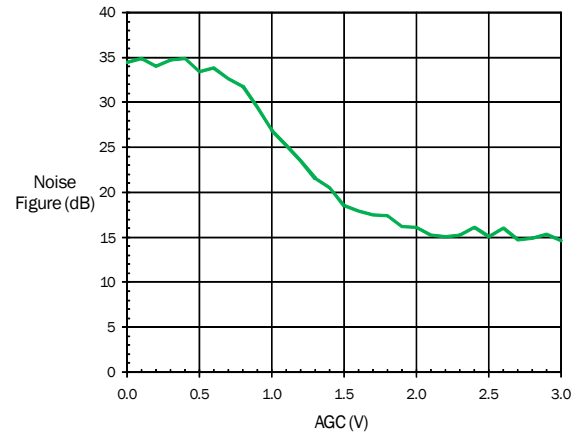

Typical Performance Curves (Continued)

Conversion Gain versus LO Power

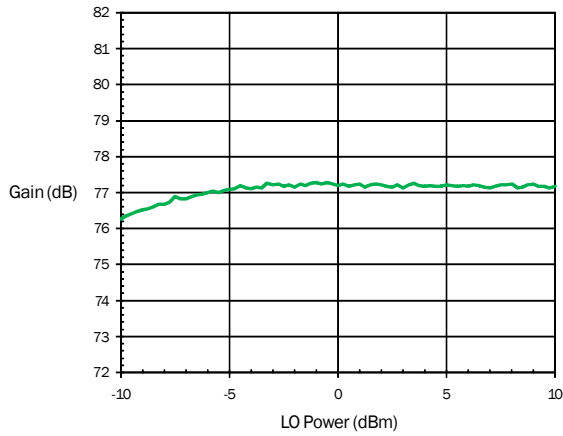

IM3 versus AGC

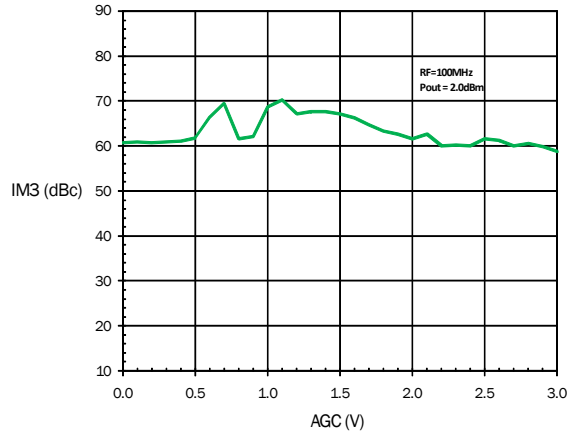

LO Leakage at RF versus LO Frequency

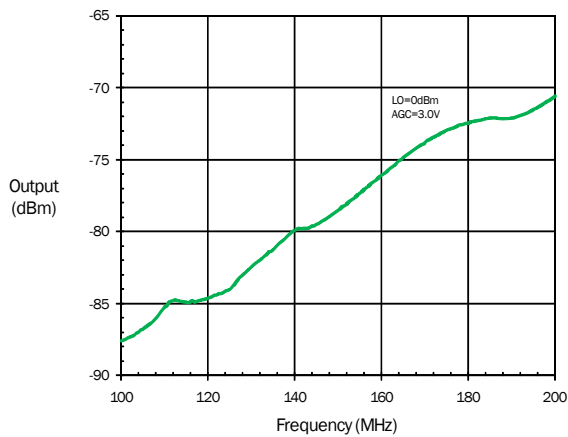

Input Voltage versus Current

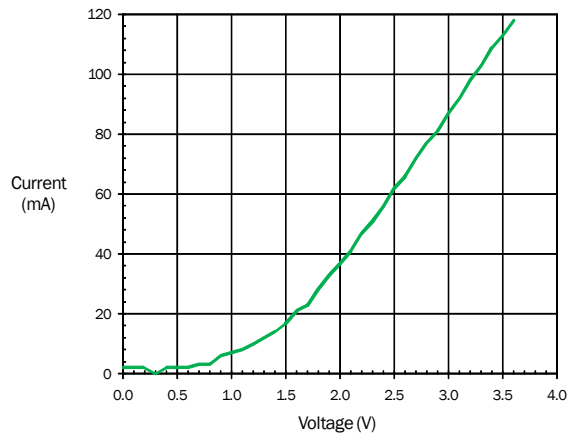

Output IP3 versus AGC

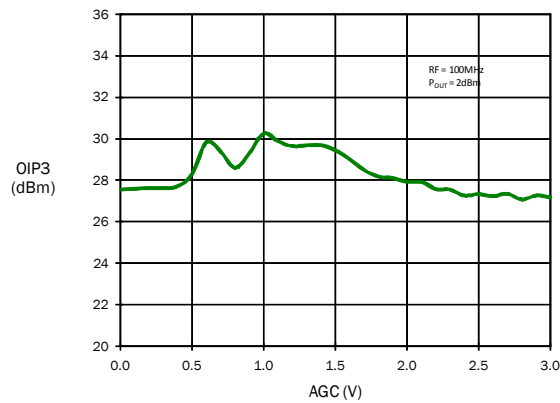

Pin	Function	Description
1	MX OUT (-)	MIXER Negative Output. Open Drain. See APPLICATION on Page 5.
2, 12	VDD	Supply Voltage, +3.3V
3	RF IN (+)	RF AMP Positive Input. Input impedance, 1K $\Omega$ single ended. See APPLICATION on Page 5.
4	RF IN(-)	RF AMP Negative Input. See APPLICATION on Page 5.
5, 6, 15	GND RF	Ground pins. Connect to ground plane with shortest possible length to minimize inductance.
7	LO IN (-)	LO Buffer Negative Input.
8	LO IN (+)	LO Buffer Positive Input.
9	AGC	Automatic Gain Control, Min Gain at AGC=0V, Max Gain at AGC=3.0V.
10	IF OUT (-)	VIDEO AMP Negative Output. This pin and IF OUT 2 form a 1K $\Omega$ output impedance. Open Drain. See APPLICATION on Page 5.
11	IF OUT (+)	VIDEO AMP Positive Output. See IF OUT (+).
13	IF IN (-)	VIDEO AMP Negative Input.
14	IF IN (+)	VIDEO AMP Positive Input.
16	MX OUT (+)	MIXER Positive Output. Open Drain. See APPLICATION on Page 5.

## Pin Configuration

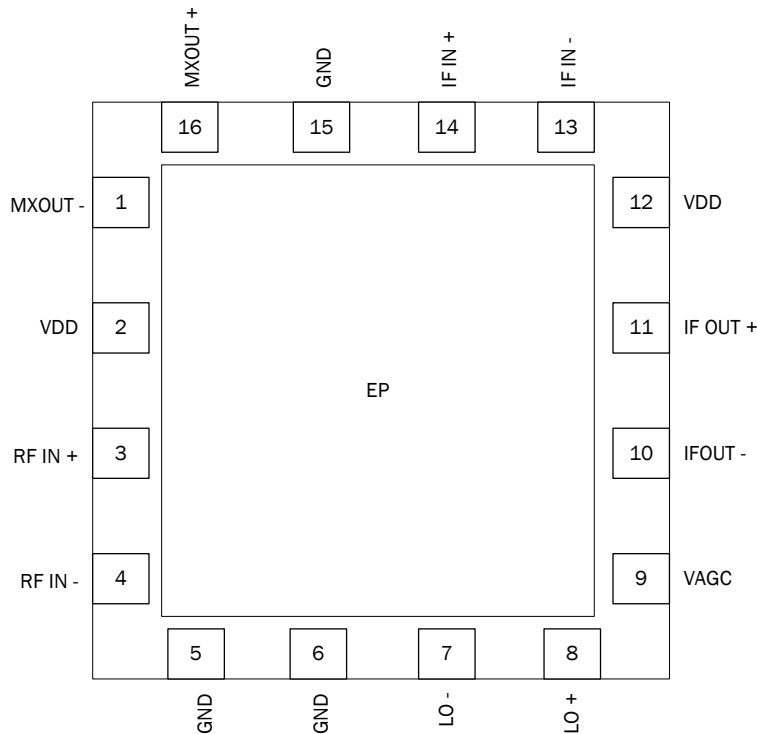

**\*Important Application Note**

The following low pass filter should proceed the RFFC0085 in all applications. This filter is used to reduce down stream interference. This low pass filter is not included on the RFFC0085 evaluation board.

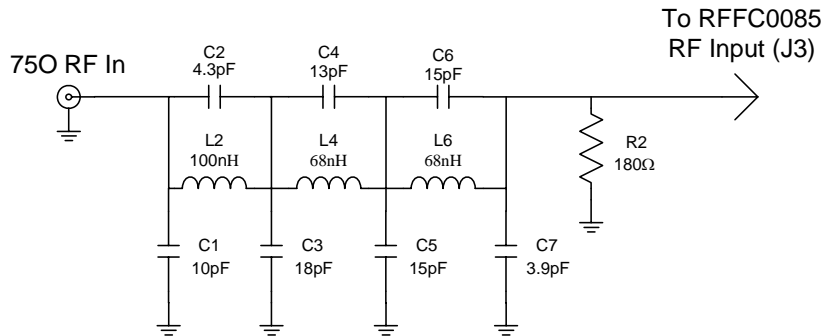

**Component List for Low Pass Filter:**

Circuit Symbol	Value
C7	3.9pF
C2	4.3pF
C1	10pF
C4	13pF
C5, C6	15pF
C3	18pF
L4, L6	68nH
L2	100nH
R2	180 ohm

## Application Circuit

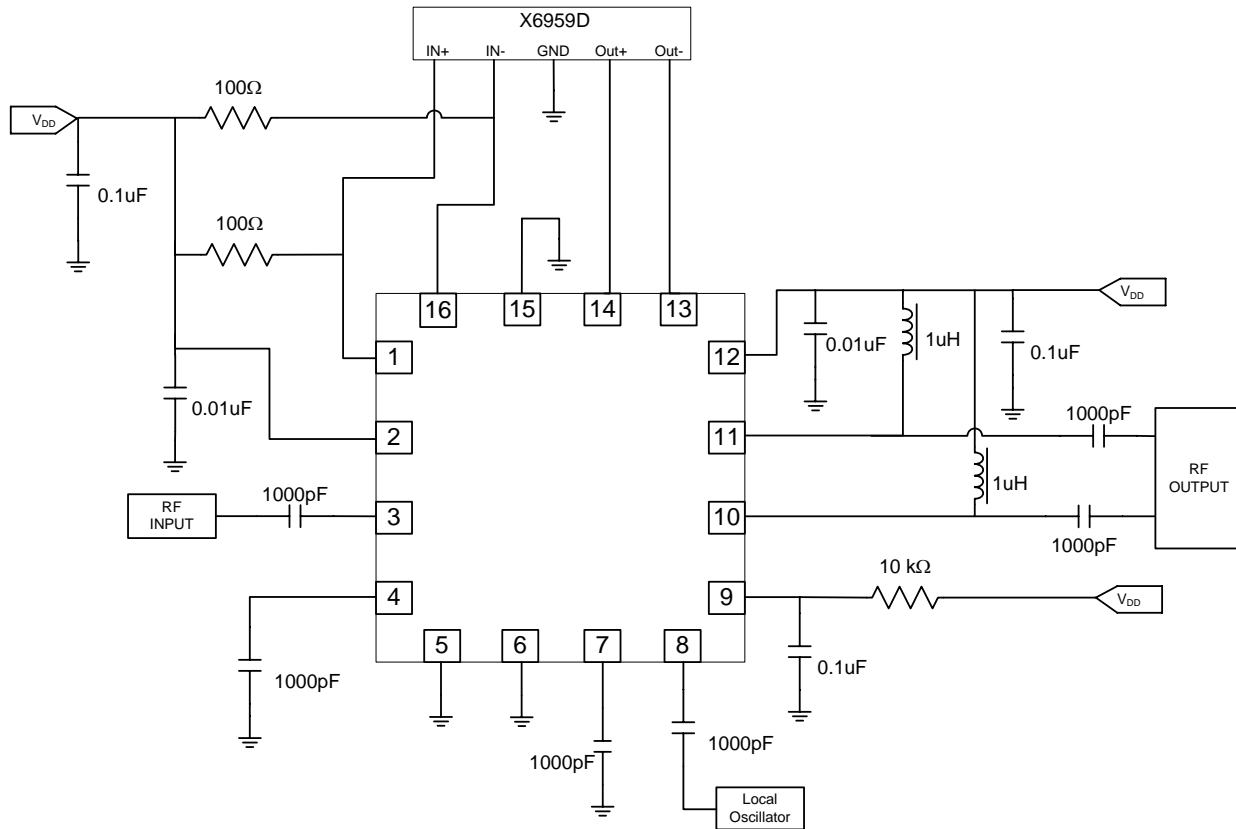

**Evaluation Board Schematic**

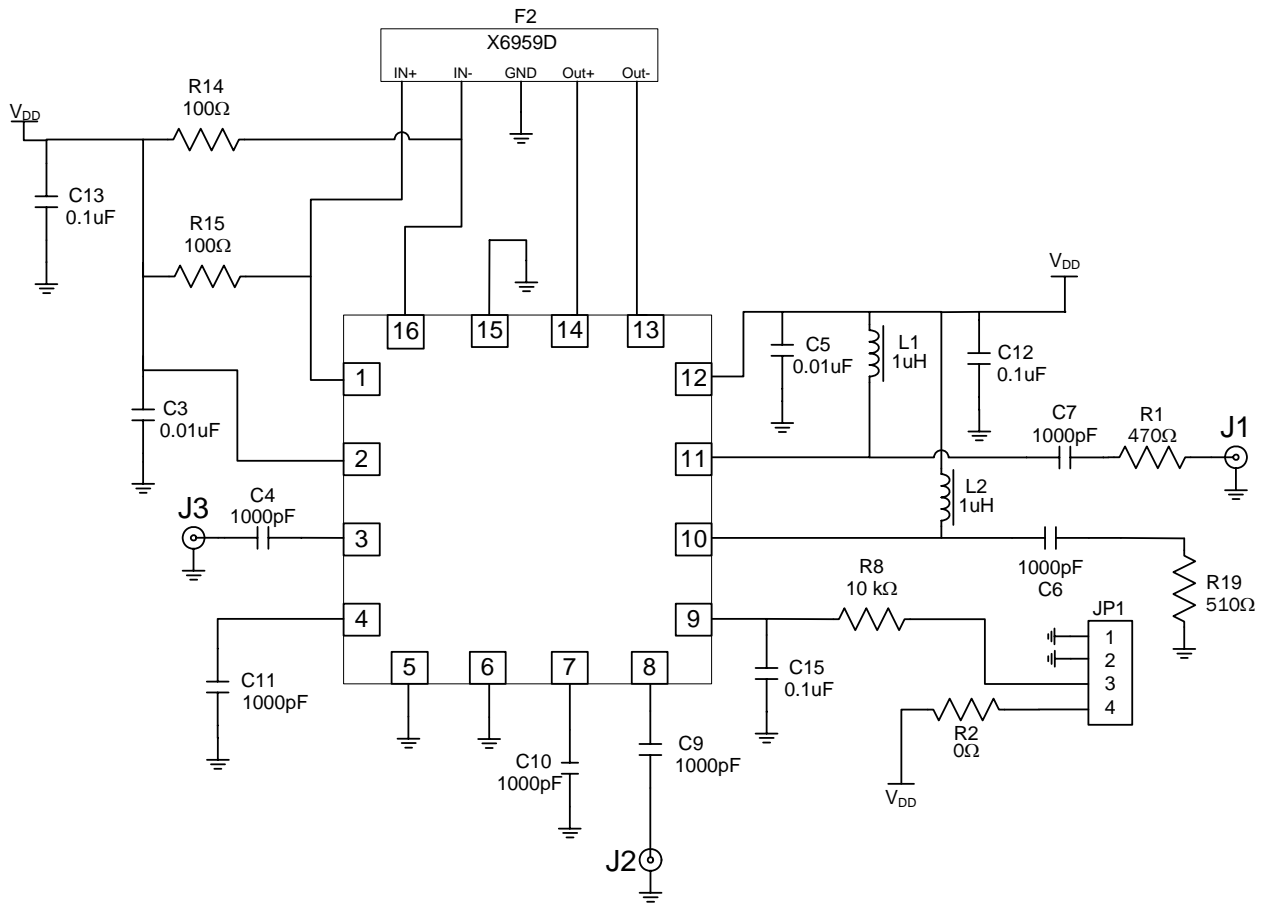

Designator	Component Type	Value	Manufacturer	Manufacturer's P/N
C3, C5	Capacitor	0.01uF	Murata Electronics	GRM155R71E103KA01D
C4, C6, C7, C9, C10, C11	Capacitor	1000pF	Murata Electronics	GRM155R71H102KA01E
C12, C13, C15	Capacitor	0.1uF	Murata Electronics	GRM155R71C104KA88D
R1	Resistor	470 ohms	Panasonic	ERJ-2GEJ471
R2	Resistor	0 ohms	Panasonic	ERJ-8GEYOR00
R14, R15	Resistor	100 ohms	Panasonic	ERJ-2GEJ101
R19	Resistor	510 ohms	Panasonic	ERJ-2GEJ511
R8	Resistor	10K ohms	Panasonic	ERJ-2GEJ103
L1, L2	Chip Bead	1uH	Steward	HZ0402B102R-10
F2	SAW Filter	44MHz	Epcos	B39440-X6959-N201
JP1	Connector	DC	Samtec	TSW-104-08-S-S
J1, J2, J3	Connector	SMA	Gigalane	PAF-S05-008

## Evaluation Board Layout

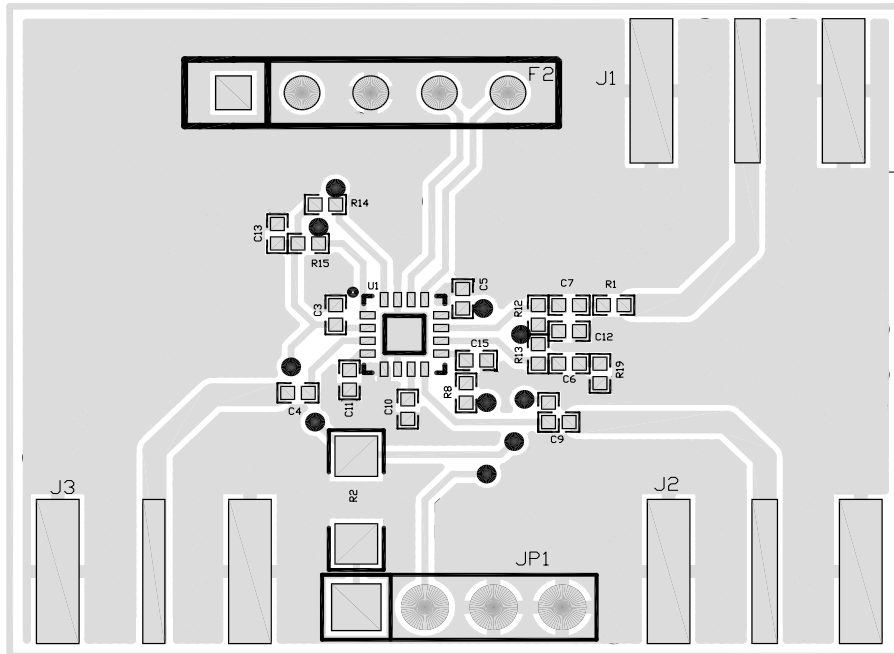

## Package Drawing

Dimensions in inches (millimeters)

Refer to drawing posted at [www.rfmd.com](http://www.rfmd.com) for tolerances.

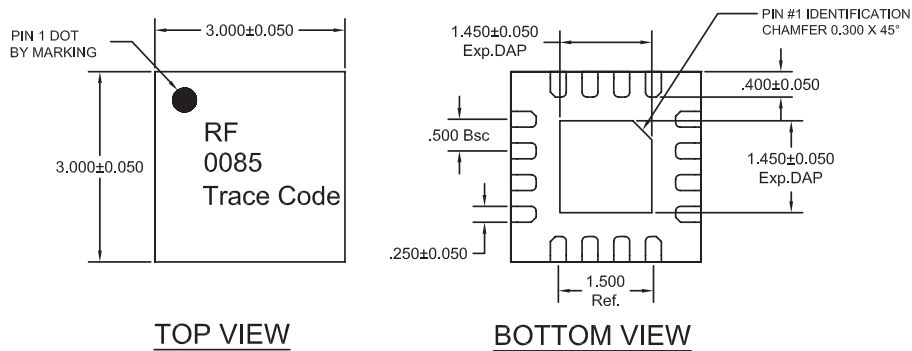



## Ordering Information

Part Number	Description
RFFC0085	25 pc Sample Bag
RFFC0085SB	5 pc Sample Bag
RFFC0085SR	100 pc Tape and Reel
RFFC0085TR7	2500 pc Tape and Reel
RFFC0085PCK-410	RFFC0085 Evaluation Board and 5 pc Sample Bag