

4

3

2

1

THIS DRAWING IS UNPUBLISHED.

RELEASED FOR PUBLICATION

© COPYRIGHT

ALL RIGHTS RESERVED.

LOC DIST

REVISIONS

P	LTR	DESCRIPTION	DATE	DWN	APVD

REPLACED BY OCEAN STYLE APPLICATOR PART NUMBER

FOR REPLACEMENT PARTS FOR APPLICATOR REFER TO ADDITIONAL PAGE(S). SPARE PARTS KIT (IF LISTED) WILL REMAIN AVAILABLE.

THE REPLACEMENT OCEAN STYLE APPLICATOR HAS THE SAME TERMINATOR/PRESS INTERFACE AS APPLICATOR

THIS DRAWING IS A CONTROLLED DOCUMENT.		DWN	 TE Connectivity		
DIMENSIONS:		CHK			
TOLERANCES UNLESS OTHERWISE SPECIFIED:		APVD	NAME		
 <ul style="list-style-type: none"> 0 PLC ± 1 PLC ± 2 PLC ± 3 PLC ± 4 PLC ± ANGLES ± 		PRODUCT SPEC	RESTRICTED TO		
		APPLICATION SPEC	SIZE	CAGE CODE	DRAWING NO
MATERIAL	FINISH	WEIGHT	A3	C-	
		SCALE	SHEET	OF	REV

PART NUMBER	REV	FIRST USED	TERMINATOR	FEED TYPE	DESCRIPTION
1238066-1	H	-	LEADMAKER	MECH POST FEED	CUTS CARRIER
1238066-2	G	-	BENCH	MECH PRE FEED	CUTS CARRIER
1238066-6	H	-	LEADMAKER	MECH POST FEED	CONTINUOUS CARRIER
7-1238066-1	H	-	LEADMAKER	MECH POST FEED	-1 AND SPARE PARTS
7-1238066-2	G	-	BENCH	MECH PRE FEED	-2 AND SPARE PARTS
7-1238066-6	H	-	LEADMAKER	MECH POST FEED	-6 AND SPARE PARTS
7-1238066-7	E	-	-	-	SPARE PARTS KIT

CRIMP DATA JST CO. TERMINAL AMP CRIMP SPECS			
TERMINAL NAME: 2.0MM PITCH HPI CRIMP CONTACT			
CRIMP	SIZE	TYPE	RANGE
WIRE	1.32 [.052 IN]	F	.05mm ² - .22mm ²
INSUL	1.50 [.059 IN]	F	0.89-1.50 [.035-.059 IN]
WIRE STRIP LENGTH		APPL INSTRUCTION	
1.91-2.49 [.075-.098 IN]		408-8322	
TERMINAL	-	-	FEED
APPL SPEC	114-57011	-	6.91 [.272 IN]
TERMINALS APPLIED			
AMP PN	MFR PN	-	-
440132	-	-	-
-	-	-	-
-	-	-	-
-	-	-	-
-	-	-	-
-	-	-	-
WIRE SIZE	CRIMP HEIGHT	PIN PN & LENGTH [IN]	
mm ² AWG			
.22mm ²	0.62-0.67 [.024-.026 IN]	6-354779-4 [.3310]	
.14mm ²	0.57-0.62 [.022-.024 IN]	6-354779-8 [.3330]	
.08mm ²	0.55-0.60 [.021-.023 IN]	7-354779-0 [.3340]	
.05mm ²	0.52-0.57 [.020-.022 IN]	7-354779-2 [.3350]	

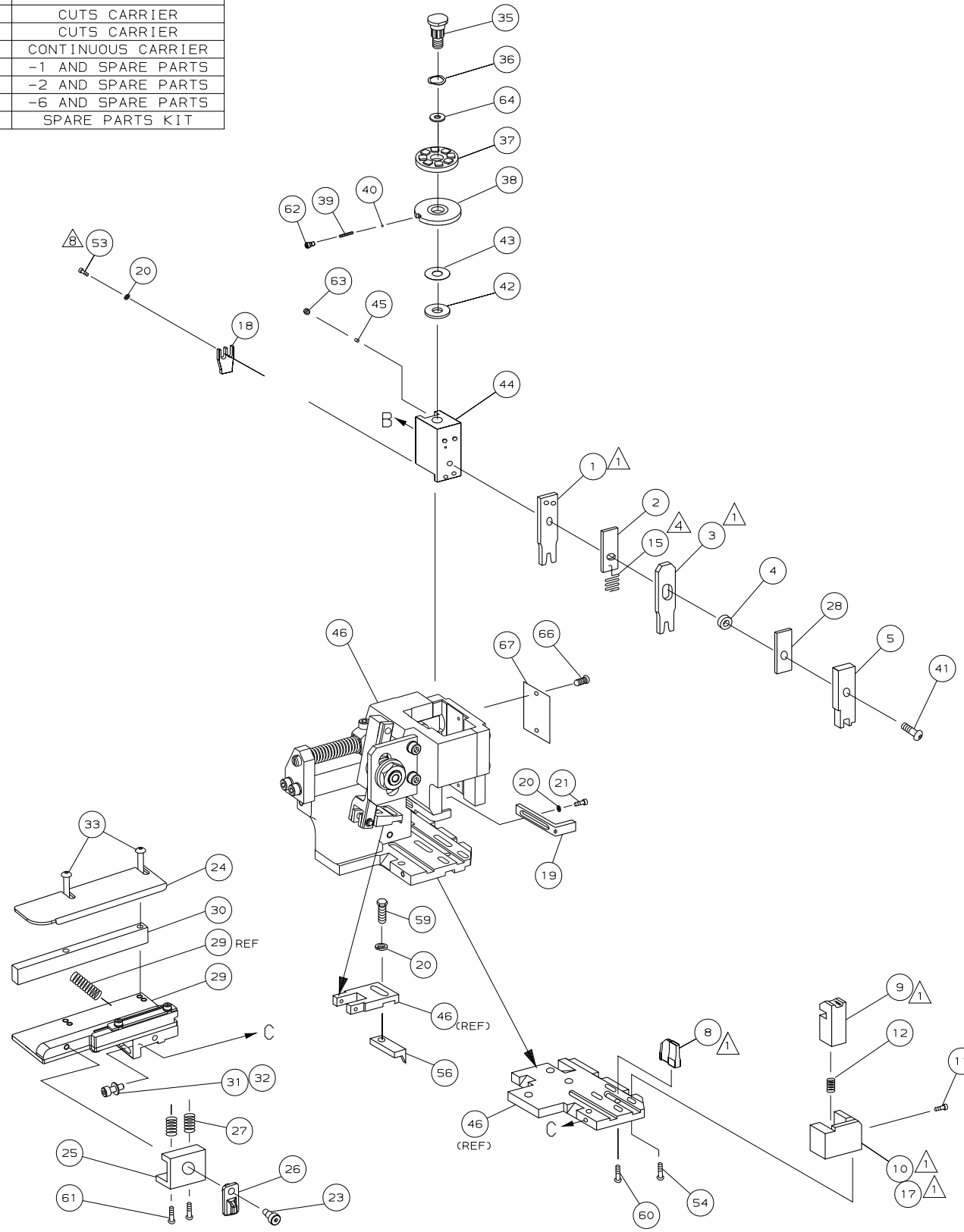

- 1. RECOMMENDED SPARE PARTS.
- 2. GREASE RAM, CAM, CAM FOLLOWER AND FEED ROD LIGHTLY.
- 3. LUBRICATE DAILY PER THE APPLICATOR INSTRUCTION SHEET SUPPLIED WITH THE APPLICATOR.
- 4. CUT TO AVOID HITTING NEXT TERMINAL.

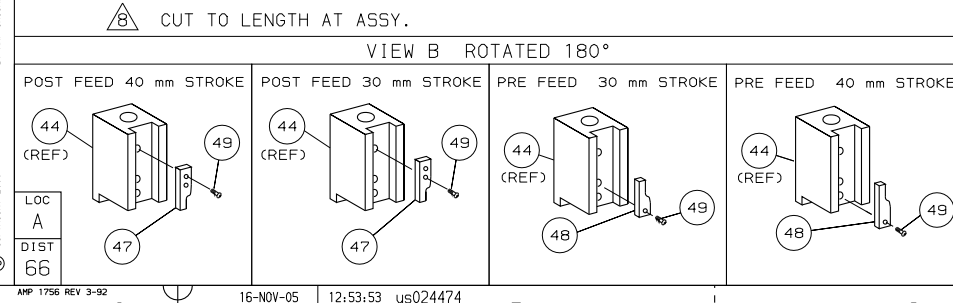

QTY	REQD	PER	ASSY	PART NO	DESCRIPTION	ITEM NO		
-	1	1	1	1	1	1385225	PRINT, APPLICATOR LOG SHEET	72
-	1	1	1	1	1	1338705-1	DOCUMENTATION PACKAGE	71
-	-	-	-	-	-	-	-	70
-	-	-	-	-	-	-	-	69
-	-	-	-	-	-	-	-	68
-	1	1	1	1	1	461264-1	PLATE, IDENTIFICATION	67
-	2	2	2	2	2	21017-2	SCR, DRIVE (#2X.19) ID PLATE	66
-	-	-	-	-	-	-	-	65
-	1	1	1	1	1	986950-1	WASHER, FLAT PRECISION	64
-	1	1	1	1	1	3-18031-0	SCR, SKT SET (M6X6) RAM	63
-	1	1	1	1	1	18023-9	SCR, SHC (M4X6) INS DISC	62
-	2	2	2	2	2	1-18024-5	SCR, BHC (M5X25) DRAG	61
-	1	1	1	1	1	18024-7	SCR, BHC (M4X10) ANVIL	60
-	1	1	1	1	1	5-18022-2	SCR, HEX (M4X8) FEED FINGER	59
-	-	-	-	-	-	-	-	58
-	-	-	-	-	-	-	-	57
-	1	1	1	1	1	1338685-1	PAWL, FEED	56
-	-	-	-	-	-	-	-	55
-	2	2	2	2	2	18024-8	SCR, BHC (M4X12) SHEAR HOLDER	54
-	2	2	2	2	2	18023-9	SCR, SHC (M4X6) TERM HLD DWN	53
-	-	-	-	-	-	-	-	52
-	-	-	-	-	-	-	-	51
-	-	-	-	-	-	-	-	50
-	1	1	1	1	1	18024-3	SCR, BHC (M3X10) CAM	49
-	-	-	-	-	-	-	-	48
-	1	1	1	1	1	1338675-1	CAM, PRE FEED 30 & 40 mm ST	48
-	1	1	1	1	1	1338676-1	CAM, POST FEED 30 & 40 mm ST	47
-	1	1	1	1	1	1320999-3	APPLICATOR BASIC SUBASSY	46
-	1	1	1	1	1	690191-1	PLUG, NYLON	45
-	1	1	1	1	1	1338660-3	RAM	44
-	1	1	1	1	1	690125-1	WASHER, LAMINATED	43
-	1	1	1	1	1	690124-1	WASHER, RAM	42
-	1	1	1	1	1	2-18024-6	SCR, BHC (M8X25) RAM	41
-	1	1	1	1	1	23241-1	BALL, STEEL	40
-	1	1	1	1	1	2-22278-7	SPRING, COMPRESSION	39
-	1	1	1	1	1	1320922-1	DISC, INSULATION	38
-	1	1	1	1	1	354777-1	WIRE DISC, PLASTIC	37
-	1	1	1	1	1	22480-5	WASHER, SPRING	36
-	1	1	1	1	1	690212-1	POST, RAM	35
-	-	-	-	-	-	-	-	34
-	2	2	2	2	2	1-18024-0	SCR, BHC (M4X20) STRIP GUIDE	33
-	1	1	1	1	1	18027-2	WASHER, FLAT (M4)	32
-	1	1	1	1	1	1-18023-2	SCR, SKT CAP (M4X12) MOUNT BLOCK	31
-	1	1	1	1	1	1320908-9	SPACER, STRIP GUIDE	30
-	1	1	1	1	1	1633073-3	STRIP GUIDE PLATE ASSY	29
-	1	1	1	1	1	1-455888-0	SPACER, FRONT SHEAR DEP	28
-	2	2	2	2	2	1-22284-0	SPRING, DRAG	27
-	1	1	1	1	1	356835-1	LEVER, DRAG RELEASE	26
-	1	1	1	1	1	240792-1	DRAG, TERMINAL	25
-	1	1	1	1	1	1320928-1	PLATE, STRIP GUIDE	24
-	1	1	1	1	1	980371-4	SCR, SHC 5HLD	23
-	-	-	-	-	-	-	-	22
-	1	1	1	1	1	1-18023-1	SCR, SHC (M4X10) STRIPPER	21
-	4	4	4	4	4	18025-2	WASHER, LOCK (M4) STRIPPER	20
-	1	1	1	1	1	1-1338987-8	STRIPPER	19
-	1	1	1	1	1	2-690518-4	HOLDER, TERMINAL	18
-	1	-	-	-	-	1338684-1	HOLDER, SHEAR, FRONT (NO-CUT)	17
-	-	-	-	-	-	-	-	16
-	1	1	1	1	1	576266-2	Z-SPRING WIRE DEPRESSOR	15
-	-	-	-	-	-	-	-	14
-	-	-	-	-	-	-	-	13
-	1	1	1	1	1	5-22280-0	SPRING, SHEAR	12
-	1	1	1	1	1	356885-6	STOP, SHEAR	11
-	-	-	-	-	-	-	-	10
-	1	1	1	1	1	1320921-1	HOLDER, SHEAR, FRONT (CUT)	10
-	1	1	1	1	1	904223-1	SHEAR, FLOAT (FRONT)	9
-	1	2	2	2	2	1338701-4	ANVIL	8
-	-	-	-	-	-	-	-	7
-	-	-	-	-	-	-	-	6
-	1	1	1	1	1	2-455889-0	DEPRESSOR, SHEAR (FRONT)	5
-	1	1	1	1	1	2-238011-0	SPACER, BLOCK CRIMPER	4
-	1	2	2	2	2	5-1213077-2	CRIMPER, INSULATION	3
-	1	1	1	1	1	793326-1	SPACER, CRIMPER	2
-	1	2	2	2	2	7-568176-6	CRIMPER, WIRE	1

QTY REQD PER ASSY

REVISION OF EACH ASSY NO (WHEN BLANK, USE DWG REVISION)

PARTS LIST

DIMENSIONS: mm [INCHES] MATL - HT TR - FIN -

DO NOT SCALE PRINT.

TOLERANCES UNLESS OTHERWISE SPECIFIED:

1 PLC DEC ±0.5 [.02 IN]

2 PLC DEC ±-

3 PLC DEC ±-

ANGLES ±-

SURF TEXTURE: ✓

REMOVE BURRS SHARP EDGES RO.3B MAX

SCALE: D DWG NO: 1238066 SHEET 1 of 1 REV H

NAME: SIDE FEED HD-I APPLICATOR MACHINE REF: HD-I APPL

DR: 06FEB01 APP: 06FEB01

C.REICHELDERFER T.ELBIN

CHK: - REL: -

AMP Incorporated Harrisburg, PA 17105-3608

DATE: 16-NOV-05 12:53:53 us024474

APP: 1756 REV 3-92

CHE CODE: 00779 CUSTOMER AND ASSEMBLY DRAWING

THIS DRAWING IS A CONTROLLED DOCUMENT

LAYOUT L2498 SET UP GAGE 458637-3

2000

RELEASED FOR PUBLICATION BY AMP INCORPORATED. ALL RIGHTS RESERVED.

THIS DRAWING IS UNPUBLISHED. © COPYRIGHT 2000

1385225

D

C

Q

B

A