

# G1G097 Series Centrifugal Blower

Ø 97mm



- DC single inlet, forward curved centrifugal blower. Reverse polarity and locked-rotor protection.
- Housing and impeller made of galvanised sheet-steel. Forward curved impellers are directly press-fitted onto the rotor of the external-rotor motor.
- Direction of rotation is CW as seen from inlet side.
- The external-rotor EC motor integrated in the impeller is mounted to the sidewall of the scroll housing.
- UL, CSA, VDE approvals on some models, please contact application engineering.

Part Number	Curve	CFM @ 0	VDC	Volt. Range	Power (W)	dB(A)	Max Amb. Temp C	Bearing Type	Features	Wgt. (lbs)
G1G097-AA05-01	1	55.9	24	16 to 28	16	59	60	Ball	No Flange	1.76
G1G097-AA07-01	1	55.9	48	36 to 57	16	59	60	Ball	No Flange	1.76

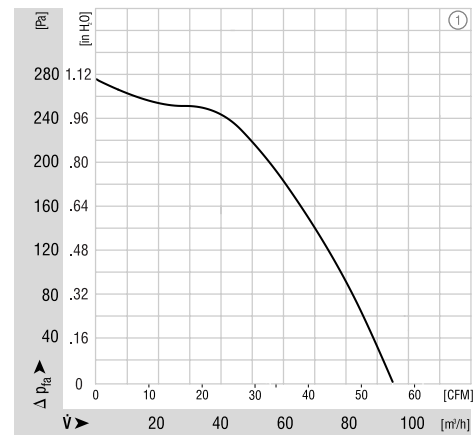
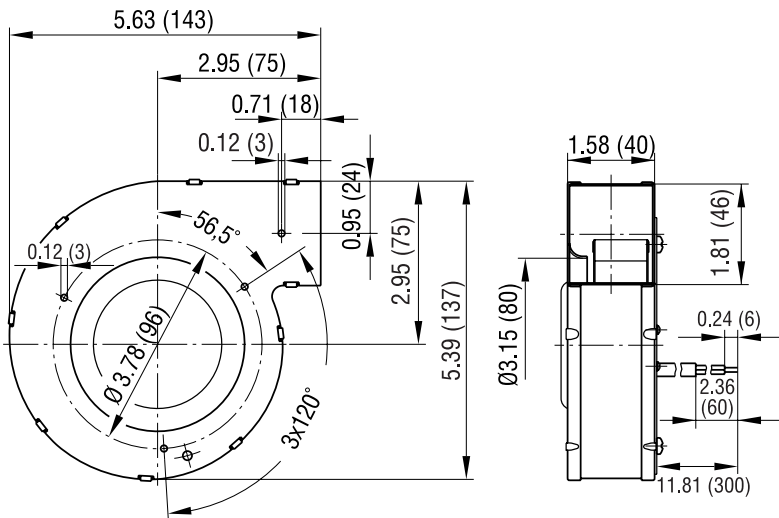

**ebmpapst**

e-mail: [sales@us.ebmpapst.com](mailto:sales@us.ebmpapst.com) · TEL: 860-674-1515 · FAX: 860-674-8536

ebm-papst Inc., 100 Hyde Road, Farmington, CT 06034 USA

ebm-papst Inc., 2006 © ebm-papst Inc. reserves the right to change any specifications or data without notice