

PART NAME: CASE      SCALE: 1:1      DATE: 8/3/70      DR. BY A.B.

THIS DRAWING IS THE PROPERTY OF DAVIES MOLDING COMPANY, IS SUBMITTED SOLELY AS A DESIGN OR ENGINEERING PROJECT. WE ACCEPT NO RESPONSIBILITY WHATSOEVER FOR THE PRACTICAL APPLICATION OF THE PIECES MADE TO THIS DESIGN.



P/N 0230	
M NO. 0230	
PIN	0230-A

CAD/REDRAWN : 8/22/94 : HD

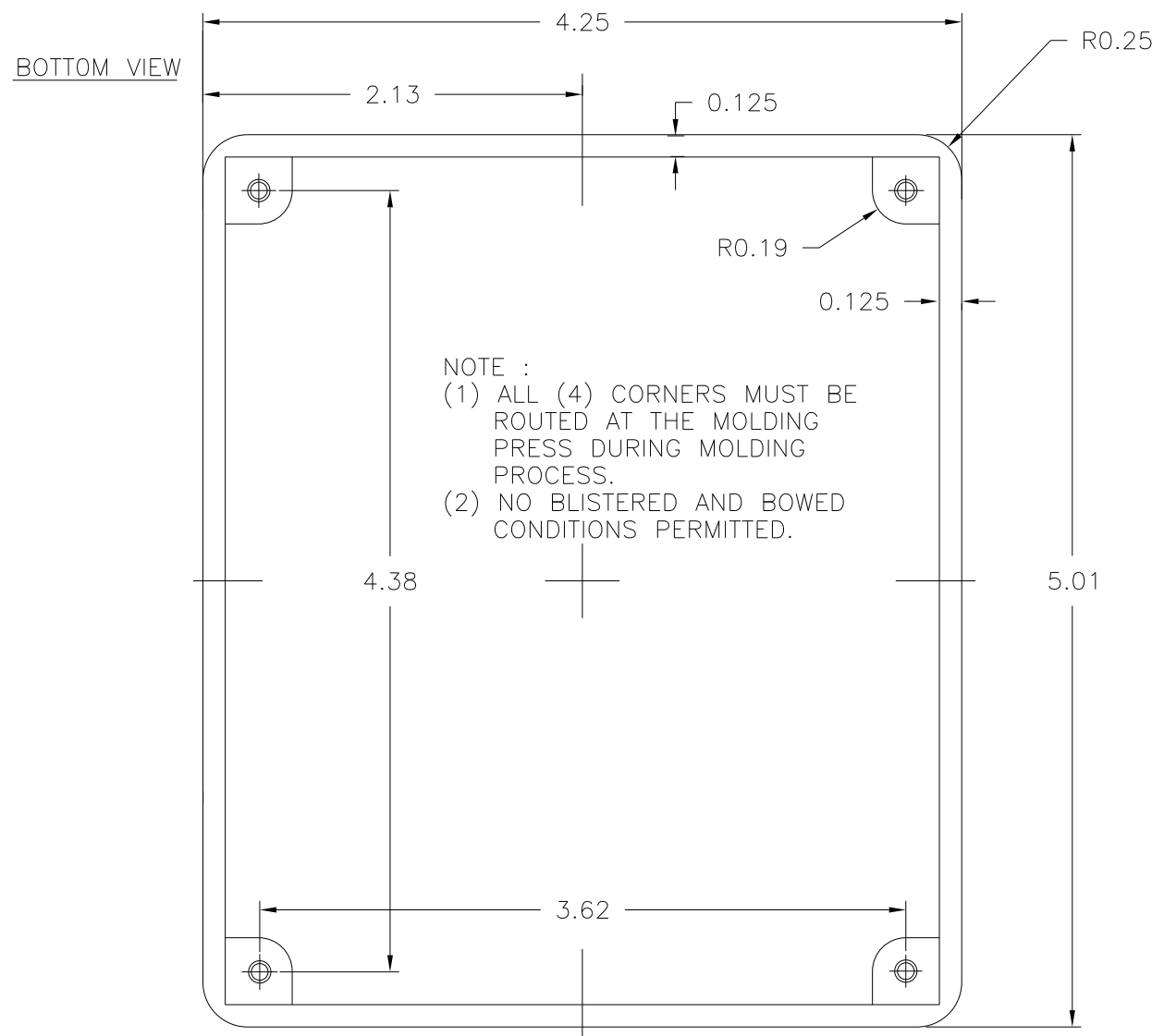

NOTE :  
 (1) ALL (4) CORNERS MUST BE ROUTED AT THE MOLDING PRESS DURING MOLDING PROCESS.  
 (2) NO BLISTERED AND BOWED CONDITIONS PERMITTED.

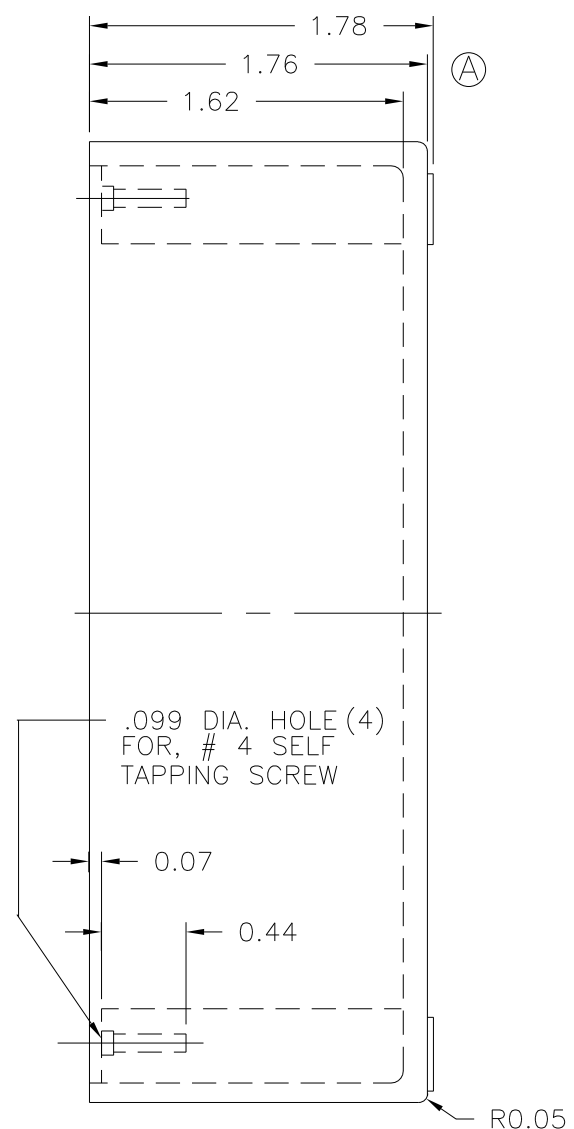

ⓑ MATERIAL: 02535 PHENOLIC (B35)  
 COLOR: BLACK

TOLERANCES: UNLESS OTHERWISE SPECIFIED	DO NOT SCALE DRAWING			
DECIMALS: X.XXX ± .005 X.XX ± .015	MM: X.XX ± 0.15MM X.X ± 0.4MM	B	WAS 02511 PHENOLIC (B11)	JAM 9/23/08
		A	ADDED 1.62, 1.75, & 1.78 DEPTH DIM.'S	DS 6/7/06
FRACTIONS ± 1/64	ANG. ± 1°	CHANGES		