

Dimensions: mm (In.)

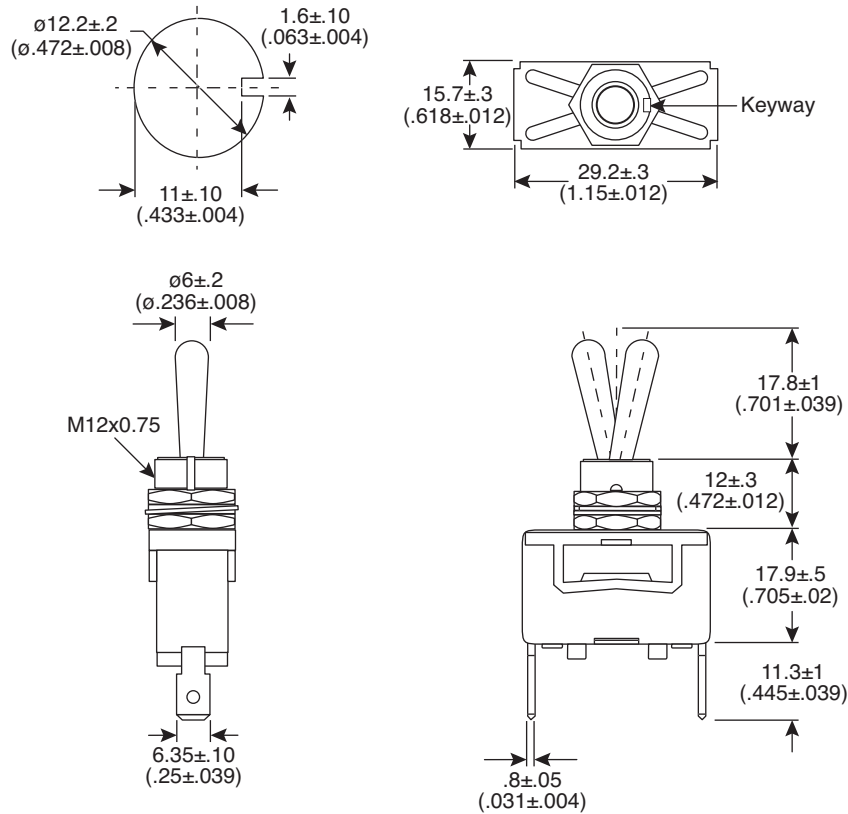

Electrical Specifications:

- Rating: 10A/250VAC 1/3HP; 15A/125VAC 1/8HP
- Contact Resistance: 50m Ω Max.
- Insulation Resistance: 500VDC 100M Ω Min.
- Dielectric Strength: 1500VAC 1 minute

Mechanical Specifications:

- Circuit: 2P SPST on-off

Note:

- RoHS Compliant by Exemption

Toggle Switch
103-0010-EVX

