



T2 Terminator Tooling Specification Sheet Part No. 63850-1500



FEATURES

- It is ideally suited for mid-volume bench operations
- This terminator can be installed in the TM42 and the TM40 press or Base Unit adapter for 3BF press
- Quick punch removal with the push of a button for fast and easy tooling change
- Track adjustment capabilities in the T2 Terminators for improved control of the bell mouth size and cutoff tab length
- T2 Terminator has standardized tooling with the Molex FineAdjust Applicator which will reduce your inventory requirements

SCOPE

Products: Mini-Fit Jr.™ Crimp Terminal 16 AWG with smaller insulation OD's.

Terminal Series No.	Terminal Order No.				Wire Size		Insulation Diameter		Strip Length	
					AWG	mm ²	mm	In.	mm	In.
5556	39-00-0077	39-00-0118	39-00-0173	39-00-0204	16	1.31	1.80-2.45	.071-.096	3.00-3.50	.118-.138
	39-00-0079	39-00-0141	39-00-0179	39-00-0211						
	39-00-0089	39-00-0157	39-00-0185	39-00-0217						
	39-00-0093	39-00-0167	39-00-0198	39-00-0447						
	39-00-0112									
5558	39-00-0081	39-00-0099	39-00-0147	40-01-0855	16	1.31	1.80-2.45	.071-.096	3.00-3.50	.118-.138
	39-00-0083	39-00-0124	39-00-0223	98-00-0176						
	39-00-0095	39-00-0130	39-00-0449							
44476	44476-3111	44476-3211			16	1.31	1.80-2.45	.071-.096	3.00-3.50	.118-.138
44478	44478-3111	44478-3211			16	1.31	1.80-2.45	.071-.096	3.00-3.50	.118-.138
44485	44485-3211	44485-3311	44485-3411		16	1.31	1.80-2.45	.071-.096	3.00-3.50	.118-.138
45750	45750-3111	45750-3211			16	1.31	2.20-2.45	.087-.096	3.00-3.50	.118-.138
46012	46012-3111	46012-3211			16	1.31	2.20-2.45	.087-.096	3.00-3.50	.118-.138
46018	46018-3541				16	1.31	2.20-2.45	.087-.096	3.00-3.50	.118-.138
46083	46083-3111	46083-3121	46083-3211	46083-3221	16	1.31	2.20-2.45	.087-.096	3.00-3.50	.118-.138
46098	46098-3541				16	1.31	2.20-2.45	.087-.096	3.00-3.50	.118-.138

⚠ This Terminator will crimp the above terminals and wires.

**However it provides optimum A-620 Class 2 crimps for 16 AWG wire
with insulation O.D. 2.20-2.45mm (example UL1007).**

Terminator 63850-1200 should be used for insulation O.D. 2.45-3.15mm (example UL1015).

DEFINITION OF TERMS

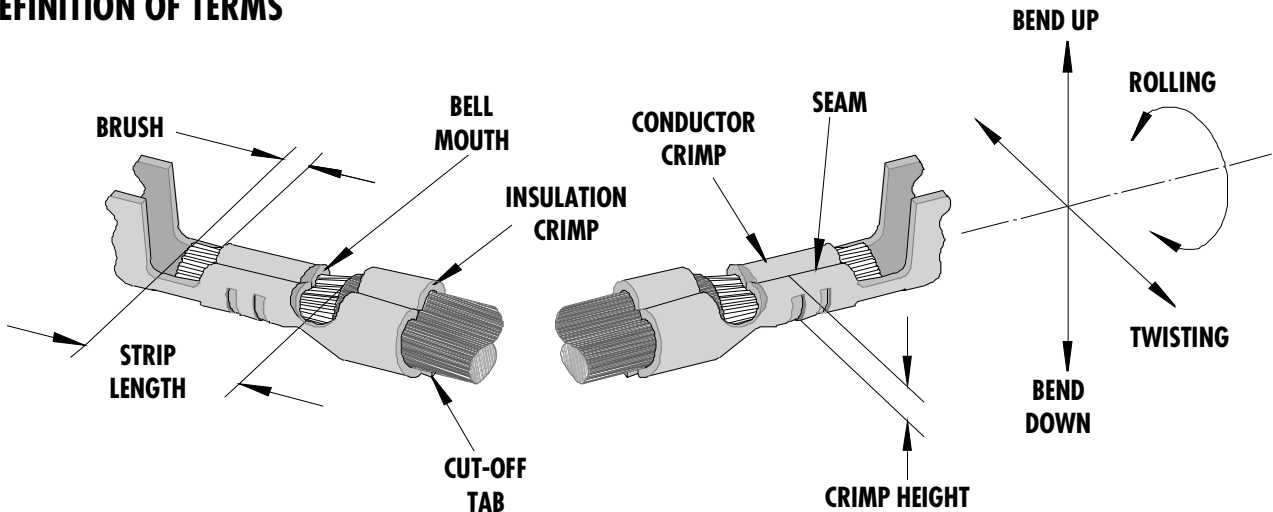

The above terminal drawing is a generic terminal representation. It is not an image of a terminal listed in the scope.

CRIMP SPECIFICATION

Terminal Series No.	Bell mouth		Cut-off Tab Max.		Conductor Brush	
	mm	In.	mm	In.	mm	In.
5556	0.20-0.50	.008-.020	0.30	.012	0.00-1.00	.000-.039
5558	0.20-0.50	.008-.020	0.30	.012	0.00-1.00	.000-.039
44476	0.20-0.50	.008-.020	0.30	.012	0.00-1.00	.000-.039
44478	0.20-0.50	.008-.020	0.30	.012	0.00-1.00	.000-.039
44485	0.20-0.50	.008-.020	0.30	.012	0.00-1.00	.000-.039
45750	0.20-0.50	.008-.020	0.30	.012	0.00-1.00	.000-.039
46012	0.20-0.50	.008-.020	0.30	.012	0.00-1.00	.000-.039
46018	0.20-0.50	.008-.020	0.30	.012	0.00-1.00	.000-.039
46083	0.20-0.50	.008-.020	0.30	.012	0.00-1.00	.000-.039
46098	0.20-0.50	.008-.020	0.30	.012	0.00-1.00	.000-.039

Terminal Series No.	Bend up	Bend down	Twist	Roll	Punch Width (Ref)				Seam Seam shall not be open And no wire allowed out of the crimping area
					Conductor		Insulation		
	Degree		Degree		mm	In.	mm	In.	
5556	5	2	5	15	1.90	.075	2.60	.102	
5558	5	2	5	15	1.90	.075	2.60	.102	
44476	5	2	5	15	1.90	.075	2.60	.102	
44478	5	2	5	15	1.90	.075	2.60	.102	
44485	5	2	5	15	1.90	.075	2.60	.102	
45750	5	2	5	15	1.90	.075	2.60	.102	
46012	5	2	5	15	1.90	.075	2.60	.102	
46018	5	2	5	15	1.90	.075	2.60	.102	
46083	5	2	5	15	1.90	.075	2.60	.102	
46098	5	2	5	15	1.90	.075	2.60	.102	

After crimping, the crimp profiles should measure the following:

Terminal Series No.	Wire Size		Conductor				Pull Force Min.	
			Crimp Height		Crimp Width (Ref)			
	AWG	mm ²	mm	In.	mm	In.	N	Lb.
5556	16	1.31	1.14-1.24	.045-.049	1.97	.078	68.4	15.4
5558	16	1.31	1.14-1.24	.045-.049	1.97	.078	68.4	15.4
44476	16	1.31	1.14-1.24	.045-.049	1.97	.078	68.4	15.4
44478	16	1.31	1.14-1.24	.045-.049	1.97	.078	68.4	15.4
44485	16	1.31	1.14-1.24	.045-.049	1.97	.078	68.4	15.4
45750	16	1.31	1.14-1.24	.045-.049	1.97	.078	68.4	15.4
46012	16	1.31	1.14-1.24	.045-.049	1.97	.078	68.4	15.4
46018	16	1.31	1.14-1.24	.045-.049	1.97	.078	68.4	15.4
46083	16	1.31	1.14-1.24	.045-.049	1.97	.078	68.4	15.4
46098	16	1.31	1.14-1.24	.045-.049	1.97	.078	68.4	15.4

 Tool Qualification Notes:

1. Pull Force should be measured with no influence from the insulation crimp.
2. The above specifications are guidelines to an optimum crimp.

PARTS LIST

T2 Terminator 63850-1500				
Item	Order No	Engineering No.	Description	Quantity
Perishable Tooling				
	63850-1570	63850-1570	Tool Kit (All "Y" Items)	REF
1	63444-1909	63444-1909	Conductor Punch	1 Y
2	63445-1943	63445-1943	Conductor Anvil	1 Y
3	63446-2610	63446-2610	Insulation Punch	1 Y
4	63445-2610	63445-2610	Insulation Anvil	1 Y
5	63443-0002	63443-0002	Cut-Off Plunger	1 Y
6	63443-0012	63443-0012	Front Plunger Retainer	1 Y
Other Components				
7	11-18-4083	60707-8	Front Cover	1
8	11-24-1067	4996-4	Cut-off Plunger Spring	1
9	11-40-4039	8302-5	Front Plunger Striker	1
10	63443-0009	63443-0009	Scrape Chute	1
11	63443-0021	63443-0021	Lower Tooling Key	1
12	63443-2408	63443-2408	Anvil Mount	1
13	63443-4018	63443-4018	Wire Stop	1
14	63443-6003	63443-6003	Rear Cover	1
Frame				
15	63800-8500	63800-8500	T2 Terminator	1
Hardware				
16	N/A	N/A	M3 by 6 Long SHCS	2**
17	N/A	N/A	M4 by 6 Long SHCS	1**
18	N/A	N/A	M4 by 10 Long BHCS	3**
19	N/A	N/A	M4 by 20 Long SHCS	1**
20	N/A	N/A	M4 by 50 Long SHCS	1**
21	N/A	N/A	M4 by 16 Long SHCS	1**
22	N/A	N/A	3MM by 6 Long Roll Pin	1**
23	N/A	N/A	#10-32 by 3/8" Long BHCS	1**

** Available from an industrial supply company such as MSC (1-800-645-7270).

Assembly Drawing

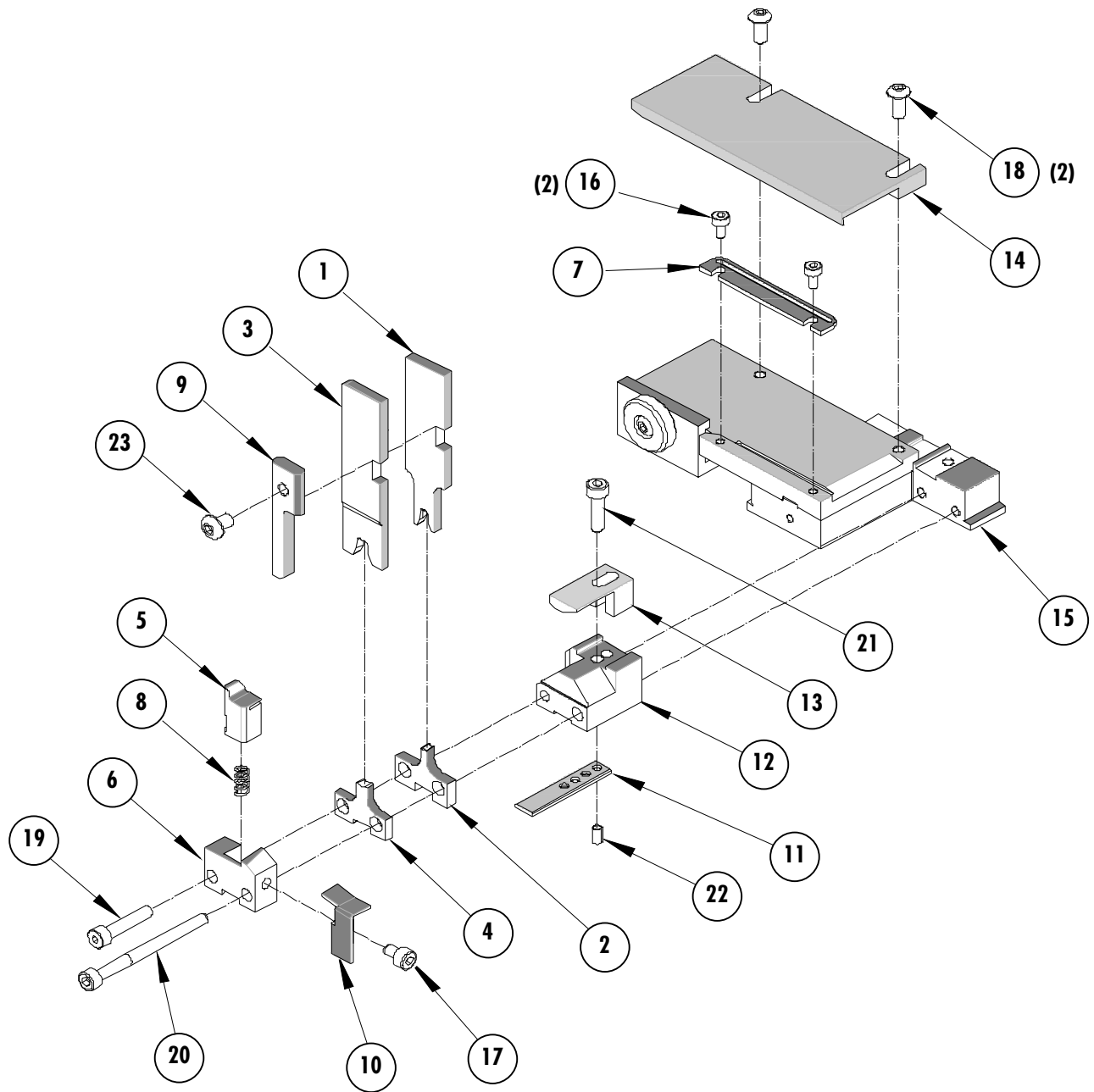

Figure 1

NOTES

Depending on the press vintage a feed finger assembly is supplied with the T2 Terminator.

1. To remove the existing feed finger assembly loosens the M4 x 10 mm set screw in the feed lever.
2. Select T2 Feed finger assembly from Terminator box.
3. Insert a screwdriver into the slot behind the feed lever and force the feed arm spring to the right.
4. Slide the T2 feed finger shaft for TM42 (11-40-5307) or (11-40-0123) for TM40 /Base Unit into the feed lever and to the left of the feed arm spring.
5. Release the feed arm spring.
6. Position feed finger for selected product. (Refer to Figure 5.1 in the T2 Manual).

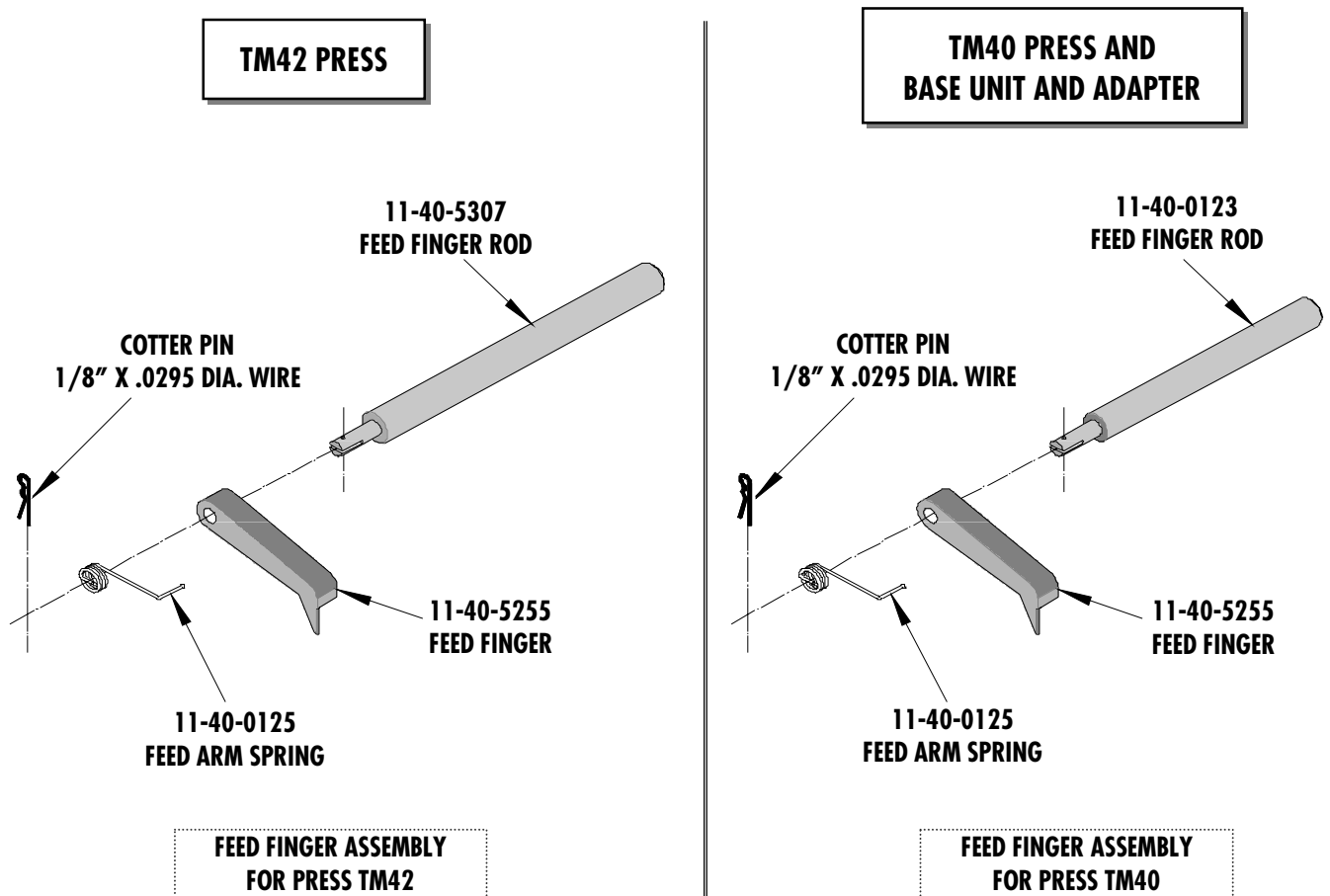

Figure 2

NOTES

1. Molex recommends an extra perishable tooling kit be maintained at your facility.
2. Verify tooling alignment by manually cycling the press before crimping under power. Check that all screws are tight.
3. Slugs, Terminals, Dirt and Oil should be kept clear of work area.
4. This Terminator should be only used in a Molex TM42, TM40, or 3BF Press with a Base Unit adaptor.
5. Wear safety glasses at all times.
6. For recommended maintenance refer to the TM40, TM42 Manual.

CAUTION: To prevent injury never operate this Terminator without the guards supplied with the press or in place. Reference the TM42 press manufacturer's instruction manual.

CAUTION: Molex crimp specifications are valid only when used with Molex terminals, applicators and tooling.

Americas Headquarters

Lisle, Illinois 60532 U.S.A.
1-800-78MOLEX
amerinfo@molex.com

Far East North Headquarters

Yamato, Kanagawa, Japan
81-462-65-2324
feninfo@molex.com

Far East South Headquarters

Jurong, Singapore
65-6-268-6868
fesinfo@molex.com

European Headquarters

Munich, Germany
49-89-413092-0
eurinfo@molex.com

Corporate Headquarters

2222 Wellington Ct.
Lisle, IL 60532 U.S.A.
630-969-4550
Fax: 630-969-1352

Visit our Web site at <http://www.molex.com>