

6N137 – High Speed 10MBd Optocouplers

Aug 2008

DESCRIPTION

These diode-transistor photocouplers consist of an AlGaAs LED optically coupled to a high speed photodetector. The output features is an open collector and coupler parameters are guaranteed over the temperature range from $-40^{\circ}\text{C} \sim 85^{\circ}\text{C}$. The internal shield provides a guaranteed Common Mode Transient Immunity (typical) $10\text{KV}/\mu\text{s}$

FEATURES

- * High speed – 10MBd
- * Common mode rejection - $10\text{KV}/\mu\text{s}$
- * UL, CSA, IEC/EN/DIN EN60747-5-2 – Pending
- * Dual-in-line package- 6N137
- * Wide lead spacing package- 6N137M
- * Surface mounting package- 6N137S
- * Tape and reel packaging- 6N137S-TA/6N137S-TA1

APPLICATIONS

- * High Voltage Isolation
- * Line receivers
- * Feedback Element in Switching Mode Power Supplies
- * High Speed Logic Ground Isolation – TTL/TTL, TTL/CMOS, TTL/LSTTL
- * Pulse transformer replacement
- * Power transistor isolation in motor drives
- * Microprocessor system interfaces
- * Ground loop elimination

Schematic

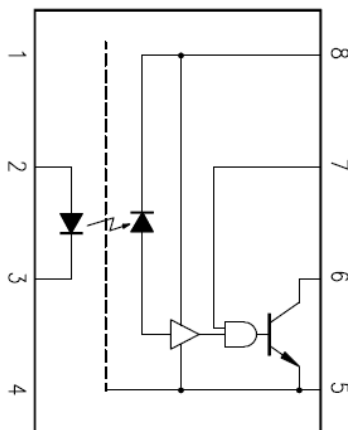

Pin Define

1. NC
2. Anode
3. Cathode
4. NC
5. GND
6. Vo
7. VE
8. Vcc

Truth Table (Positive Logic)

Input	EN	Output
ON	H	L
OFF	H	H
ON	L	H
OFF	L	H
ON	NC	L
OFF	NC	H

A 0.1uF bypass capacitor must be connected between pin8 and pin5.

OUTLINE DIMENSIONS

6N137:

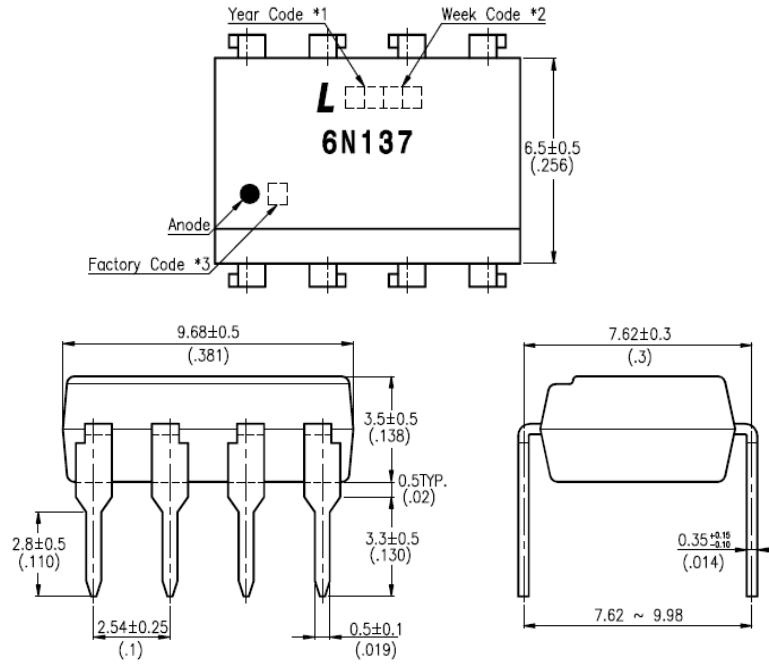

6N137M

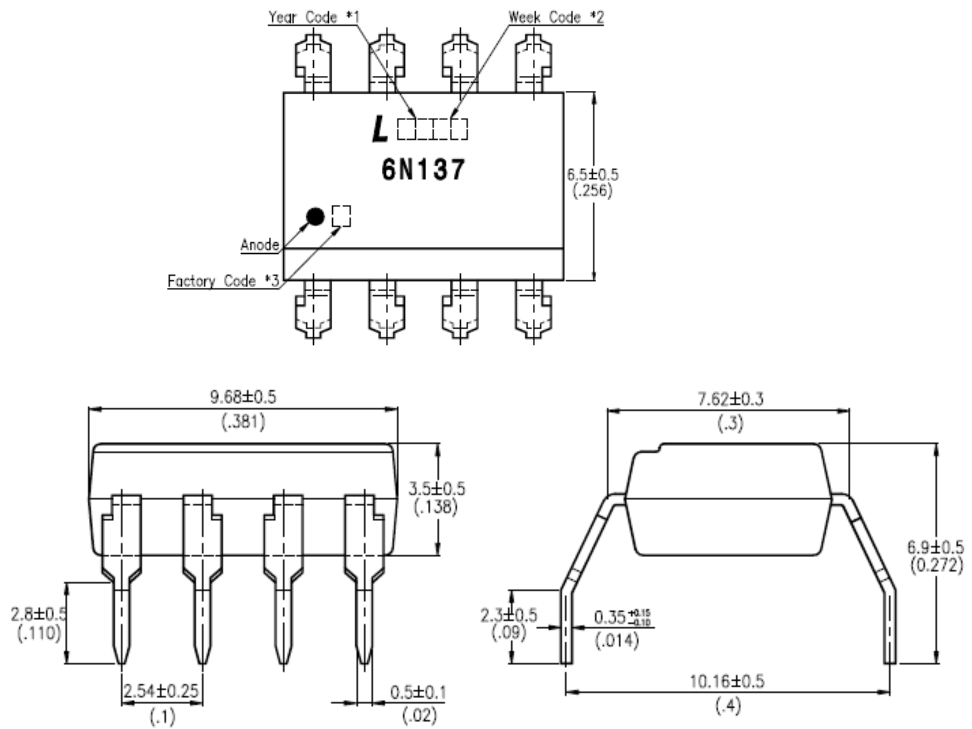

OUTLINE DIMENSIONS

6N137S

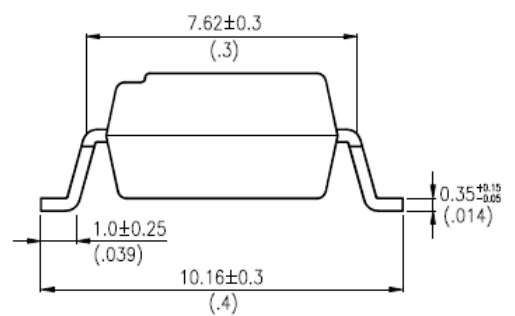
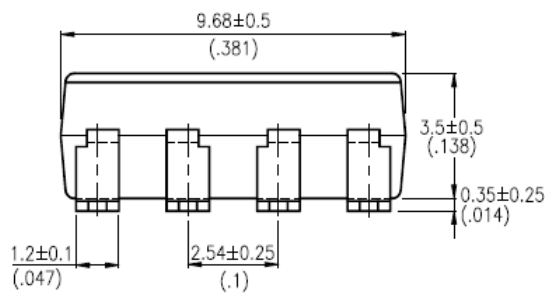
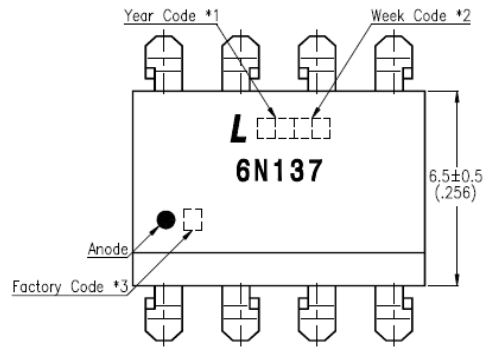

- *1. Year date code.
- *2. 2-digit work week.
- *3. Factory identification mark shall be marked (Z: Taiwan, Y: Thailand).

TAPING DIMENSIONS

6N137S-TA

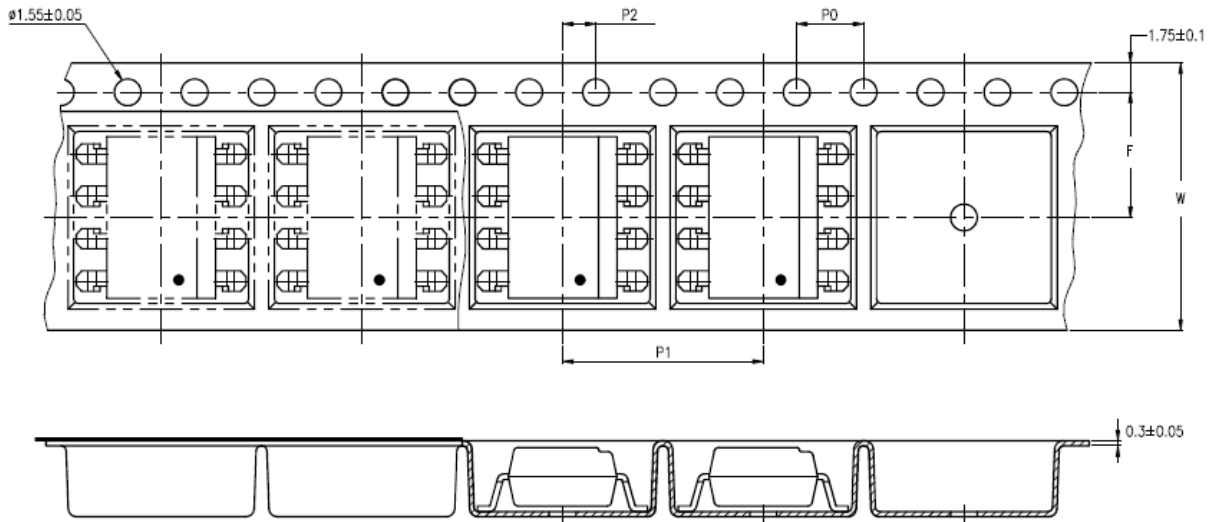

6N137S-TA1

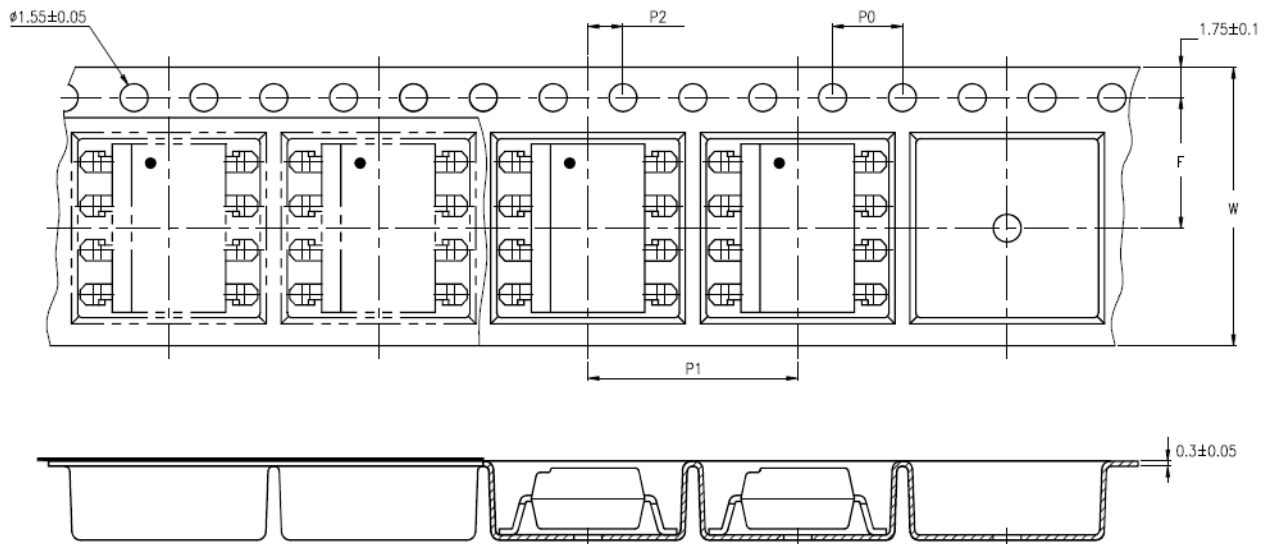

Description	Symbol	Dimensions in mm (inches)
Tape wide	W	16 ± 0.3 (.63)
Pitch of sprocket holes	P_0	4 ± 0.1 (.15)
Distance of compartment	F	7.5 ± 0.1 (.295)
Distance of compartment to compartment	P_2	2 ± 0.1 (.079)
Distance of compartment to compartment	P_1	12 ± 0.1 (.472)

ABSOLUTE MAXIMUM RATING

(Ta = 25°C unless otherwise specified)

PARAMETER		SYMBOL	RATING	UNIT
INPUT	Forward Current	I _F	25	mA
	Reverse Voltage	V _R	5	V
	Power Dissipation	P	40	mW
OUTPUT	Supply Voltage (1minute max)	V _{CC}	7	V
	Output Voltage	V _O	7	V
	Output Current	I _O	50	mA
	Power Dissipation	P _O	85	mW
	Isolation Voltage	V _{iso}	5000	V _{rms}
	Operating Temperature	T _{opr}	-40 ~ +85	°C
	Storage Temperature	T _{stg}	-55 ~ +125	°C
	Soldering Temperature	T _{sol}	260 for 10 sec	°C

Note

1. AC For 1 Minute, R.H. = 40 ~ 60%
 Isolation voltage shall be measured using the following method.
 - (1) Short Pin 1 to Pin4 on the primary side and Pin 5 to Pin 8 on the secondary side.
 - (2) The isolation voltage tester with zero-cross circuit shall be used.
 - (3) The waveform of applied voltage shall be a sine wave.
2. For 10 sec.

ELECTRICAL - OPTICAL CHARACTERISTICS

(T_A = 0~70°C, unless otherwise specified)

PARAMETER	SYMBOL	MIN.	TYP.**	MAX.	UNIT	CONDITIONS
Input						
Input Forward Voltage	V _F	—	1.45	1.7	V	T _a =25°C, I _F =10mA
Input Forward Voltage Temperature Coefficient	ΔV _F /ΔT _a	—	-1.6	—	mV/°C	I _F =10mA
Input Reverse Voltage	BV _R	5.0	—	—	V	T _a =25°C, I _R =10 μA
Output						
High Level Supply Current	I _{CCH}	—	7	10	mA	I _F =0mA, V _E =0.5V V _{CC} =5.5V
Low Level Supply Current	I _{CCL}	—	9	13	mA	I _F =10mA, V _E =0.5V V _{CC} =5.5V
Low Level Enable Current	I _{EL}	—	-0.8	-1.6	mA	V _{CC} =5.5V, V _E =0.5V
High Level Enable Current	I _{EH}	—	-0.6	-1.6	mA	V _{CC} =5.5V, V _E =2.0V
High Level Enable Voltage	V _{EH}	2.0			V	I _F =10mA, V _{CC} =5.5V
Low Level Enable Voltage	V _{EL}			0.8	V	I _F =10mA, V _{CC} =5.5V

** All typical at T_A = 25°C

SWITCHING SPECIFICATIONS (AC)

($T_A = -40\sim 85^\circ\text{C}$, $V_{CC} = 5\text{V}$, $I_F = 7.5\text{mA}$ unless otherwise specified)

PARAMETER	SYM.	MIN.	TYP**	MAX.	UNIT	CONDITIONS
Propagation Delay time to Logic Low Output (1)→(0)	t_{PHL}	25	30	75	ns	$R_L = 350\Omega$ $C_L = 15\text{pF}$
				100		
Propagation Delay time to Logic High Output (0)→(1)	t_{PLH}	25	40	75	ns	$R_L = 350\Omega$ $C_L = 15\text{pF}$
				100		
Pulse Width Distortion	$ t_{PHL} - t_{PLH} $		10		ns	$R_L = 350\Omega$ $C_L = 15\text{pF}$
Output Rise Time (10%~90%)	t_r		50		ns	$R_L = 350\Omega$ $C_L = 15\text{pF}$
Output Fall time (90%~10%)	t_f		12		ns	$R_L = 350\Omega$ $C_L = 15\text{pF}$
Enable Propagation Delay Time at high level output(1)	t_{ELH}		20		ns	$I_F = 7.5\text{mA}$ $V_{EH} = 3.5\text{V}$ $R_L = 350\Omega$ $C_L = 15\text{pF}$
Enable Propagation Delay Time at low level output(0)	t_{EHL}		20		ns	$I_F = 7.5\text{mA}$ $V_{EH} = 3.5\text{V}$ $R_L = 350\Omega$ $C_L = 15\text{pF}$
Instantaneous common mode rejection at high logic output (1)	$ CM_H $	1	10	—	KV / μs	$I_F = 0\text{mA}$ $V_{OH}(\text{Min}) = 2.0\text{V}$ $ V_{CM} = 50\text{V}_{P-P}$ $R_L = 350\Omega$
Instantaneous common mode rejection at low logic output (0)	$ CM_L $	1	10	—	KV / μs	$I_F = 7.5\text{mA}$ $V_{OH}(\text{Max}) = 0.8\text{V}$ $ V_{CM} = 50\text{V}_{P-P}$ $R_L = 350\Omega$

** All typical at $T_A = 25^\circ\text{C}$

SWITCHING TEST CIRCUITS (AC)

Switching Time Test Circuit

(t_{PHL} , t_{PLH} , t_r and t_f)

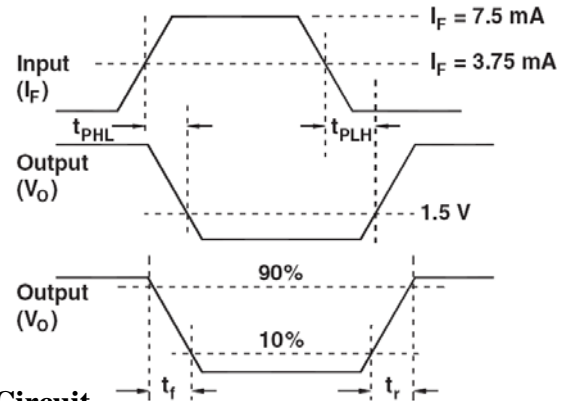
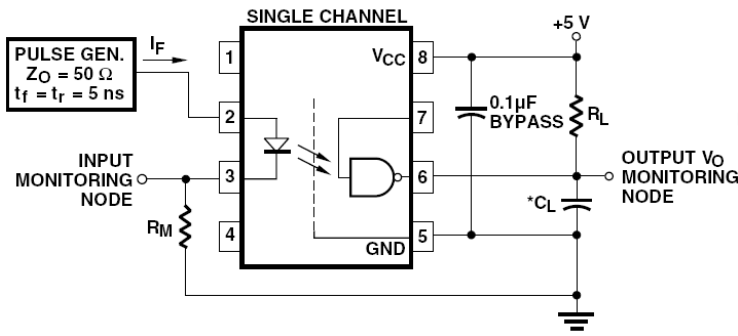

Switching Time Test Circuit

(t_{EHL} , t_{ELH})

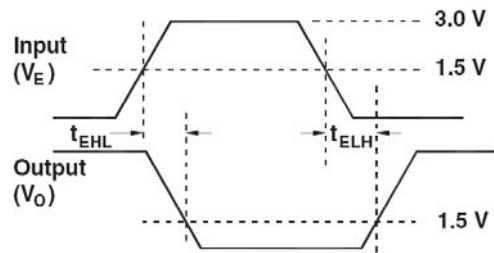
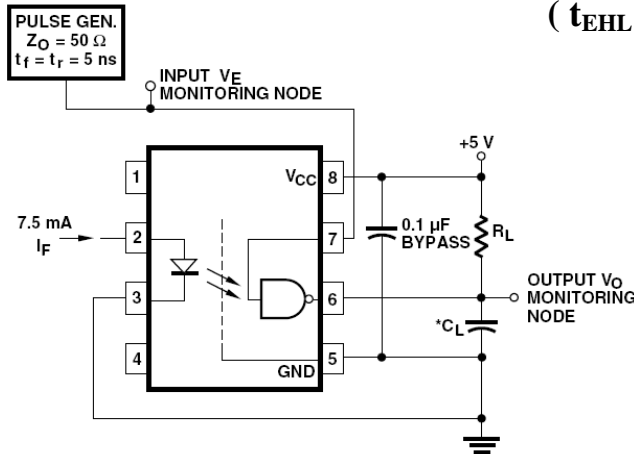

Common Mode Immunity Test Circuit

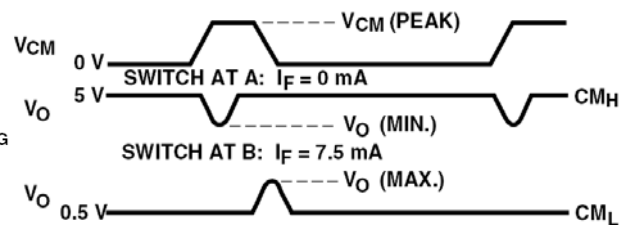
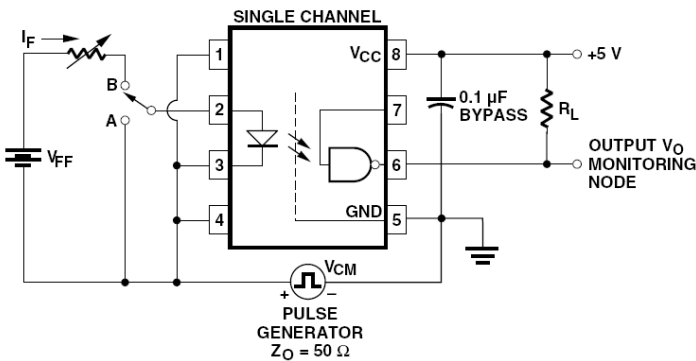

ISOLATION CHARACTERISTICS

($T_A = -40\sim 85^\circ\text{C}$, $V_{CC} = 5\text{V}$, $I_F = 7.5\text{mA}$ unless otherwise specified)

PARAMETER	SYMBOL	MIN.	TYP.**	MAX.	UNIT	CONDITIONS
Isolation Resistance (Input-output) Note4.	R_{I-O}	—	10^{12}	—		$T_a=25^\circ\text{C}$, $RH<45\%$, $V_{I-O}=500\text{V DC}$
Capacitance (Input-output) Note4.	C_{I-O}	—	0.6	—	pF	$f=1\text{MHz}$

TRANSFER CHARACTERISTICS(DC)

($T_A = -40\sim 85^\circ\text{C}$, $V_{CC} = 5\text{V}$, $I_F = 7.5\text{mA}$ unless otherwise specified)

PARAMETER	SYMBOL	MIN.	TYP.**	MAX.	UNIT	CONDITIONS
High Level Output Current	I_{OH}			100	μA	$V_{CC}=5.5\text{V}$, $V_o=0.5\text{V}$ $I_F=250\mu\text{A}$, $V_E=2.0\text{V}$
Low Level Output Voltage	V_{OL}		0.35	0.6	V	$V_{CC}=5.5\text{V}$, $I_F=5\text{mA}$, $V_E=2.0\text{V}$ $I_{OL}=13\text{mA}$
Input Threshold Current	I_{FTH}		3	5	mA	$V_{CC}=5.5\text{V}$, $V_o=0.5\text{V}$ $I_{OL}=13\text{mA}$, $V_E=2.0\text{V}$

** All typical at $V_{CC}=5\text{V}$, $T_A = 25^\circ\text{C}$

Note:

- AC For 1 Minute, R.H. = 40 ~ 60%
Isolation voltage shall be measured using the following method.
(1) Considered a two-terminal device: Pin 1,2,3,4 shorted together and Pin 5,6,7,8 shorted together.
(2) The isolation voltage tester with zero-cross circuit shall be used.
(3) The waveform of applied voltage shall be a sine wave.
- For 10 sec.
- Pin5 and Pin8 must connect a bypass 0.1 μF capacitor.

Notes:

- Lite-On is continually improving the quality, reliability, function or design and Lite-On reserves the right to make changes without further notices.
- The products shown in this publication are designed for the general use in electronic applications such as office automation equipment, communications devices, audio / visual equipment, electrical application and instrumentation.
- For equipment/devices where high reliability or safety is required, such as space applications, nuclear power control equipment, medical equipment, etc, please contact our sales representatives.
- When requiring a device for any "specific" application, please contact our sales in advance.
- If there are any questions about the contents of this publication, please contact us at your convenience.
- The contents described herein are subject to change without prior notice.
- Do not immerse unit's body in solder paste.