

Jul.1.2019 Copyright 2019 HIROSE ELECTRIC CO., LTD. All Rights Reserved.
 In case of consideration for using Automotive equipment / device which demand high reliability, kindly contact our sales window correspondents.

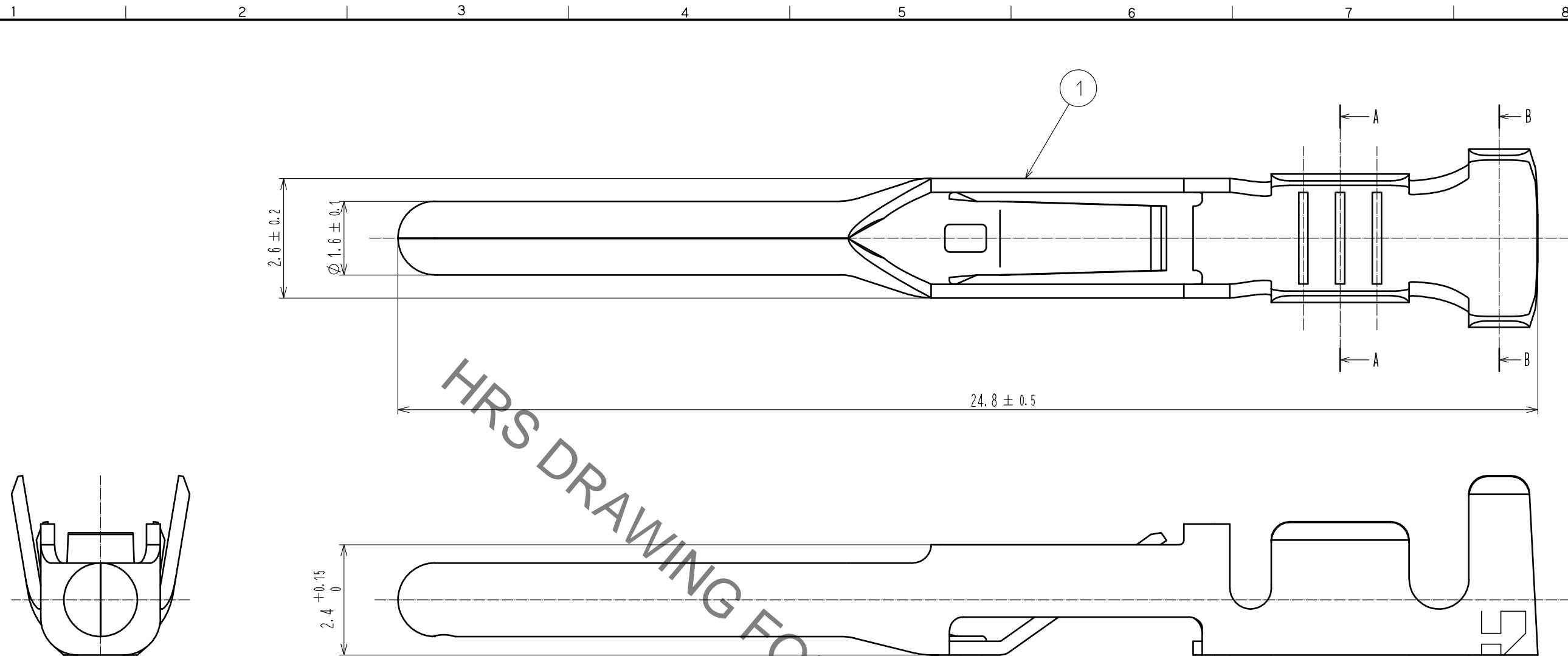

- Notes
- 1 This product is apply to the wire #16 to #20.
(Jacket diameter : ϕ 1.9 to 3.2mm)
 - 2 Applicable crimping tool : HT802/HR41A-11-16 (CL150-0408-5)(Applicable to AWG#16)
HT802/HR41A-11-18 (CL150-0404-4)(Applicable to AWG#18)
HT802/HR41A-11-20 (CL150-0407-2)(Applicable to AWG#20)
 - 3 Applicable extraction tool : HR41A-TP(CL150-0405-7)
 - 4 Per reel : 100 contacts
 - 5 Contact plating : Gold plating 0.76 μ m min.
 - 1 Terminal plating : Tin plating 0.5 μ m min.
Underplating : Nickel plating 2 μ m min.

1	Copper alloy	5						
NO.	MATERIAL	FINISH .	REMARKS	NO.	MATERIAL	FINISH .	REMARKS	
UNITS		SCALE	COUNT	DESCRIPTION OF REVISIONS		DESIGNED	CHECKED	DATE
mm		10 : 1	1	DIS-C-00000101		HN. TANAKA	HY. KISHI	15. 02. 10
HRS HIROSE ELECTRIC CO., LTD.		APPROVED : SU. OBARA	14. 05. 16	DRAWING NO.		EDC3-118389-00		
		CHECKED : HY. KISHI	14. 05. 16	PART NO.		HR41A-PC-111		
		DESIGNED : HN. TANAKA	14. 05. 15	CODE NO.		CL141-0214-8-00		
		DRAWN : HN. TANAKA	14. 05. 15					