

- 1. CONTACTS INCLUDED IN ASSEMBLY.
- CONTACT
 BODY MATL: BERYLLIUM COPPER PER ASTM-B-197.
 BODY FINISH: PLATED GOLD, .000050 MIN THK PER MIL-G-45204 OVER NICKEL, .000050 MIN THK PER QQ-N-290.
 HOOD MATL: STAINLESS STEEL PER ASTM-A-167.
 HOOD FINISH: PASSIVATED PER ASTM-A-380.
- MATL: BRASS PER ASTM-B-36.
- FINISH: PLATED GOLD, .000050 MIN THK PER MIL-G-45204 OVER COPPER, .000100 MIN THK PER MIL-C-14550.

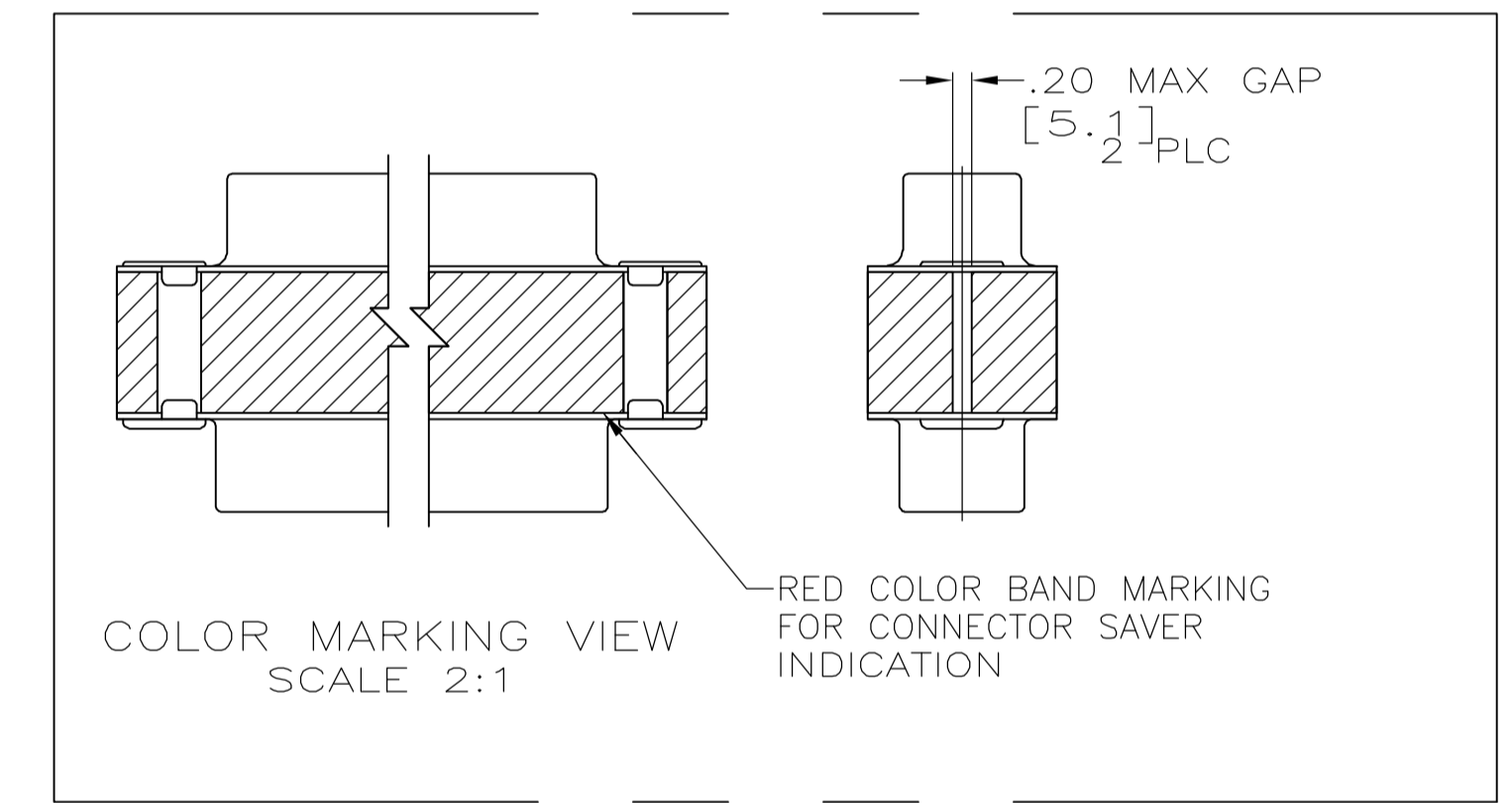
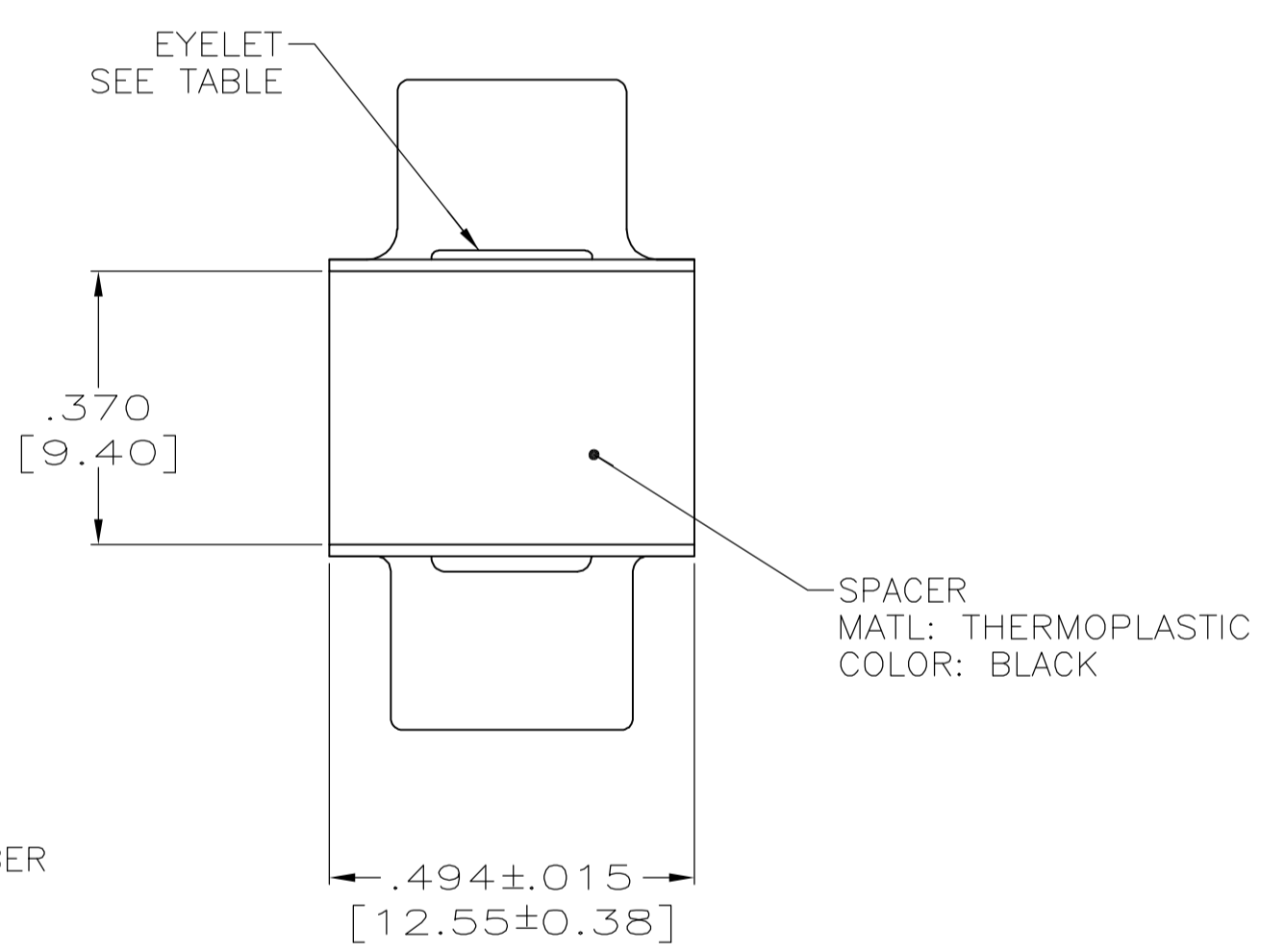

③ ④	③ ④	②	4U884 SOCN R10002677-0006	1218308-2
③ ④	③ ④	②	(1J02-006)	1218308-1
EYELET	SHELLS	CONTACT	CUSTOMER P/N	PART NO.
THIS DRAWING IS A CONTROLLED DOCUMENT.		DWN T. THOMPSON 19AUG98	Tyco Electronics Corporation Harrisburg, PA 17105-3608	
DIMENSIONS: INCHES		CHK J. NORTON 19AUG98	Tyco Electronics	
TOLERANCES UNLESS OTHERWISE SPECIFIED:		APVD J. NORTON 19AUG98	NAME	
0 PLC ± -	1 PLC ± -	PRODUCT SPEC	AMPLIMITE CONNECTOR SAVER	
2 PLC ± -	3 PLC ± -	APPLICATION SPEC	SERIES 90, SIZE 1, 15 POS	
4 PLC ± -	ANGLES ± -	SIZE	NON-REMOVABLE CONTACTS	
MATERIAL -	FINISH -	WEIGHT -	SIZE A1	CAGE CODE 00779
CUSTOMER DRAWING			DRAWING NO. 1218308	RESTRICTED TO
SCALE 4:1			SHEET 1 OF 1	REV E