

THIS DOCUMENT IS THE PROPERTY OF KEYSTONE ELECTRONICS CORP. AND SHALL NOT BE REPRODUCED, DISTRIBUTED OR USED AS A BASIS FOR MANUFACTURE WITHOUT PRIOR WRITTEN PERMISSION FROM KEYSTONE ELECTRONICS CORP.

**MOUNTING PAD LAYOUT**

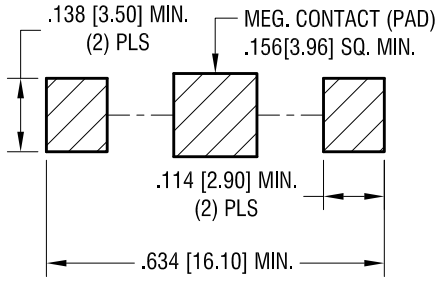

**ACTUAL SIZE**

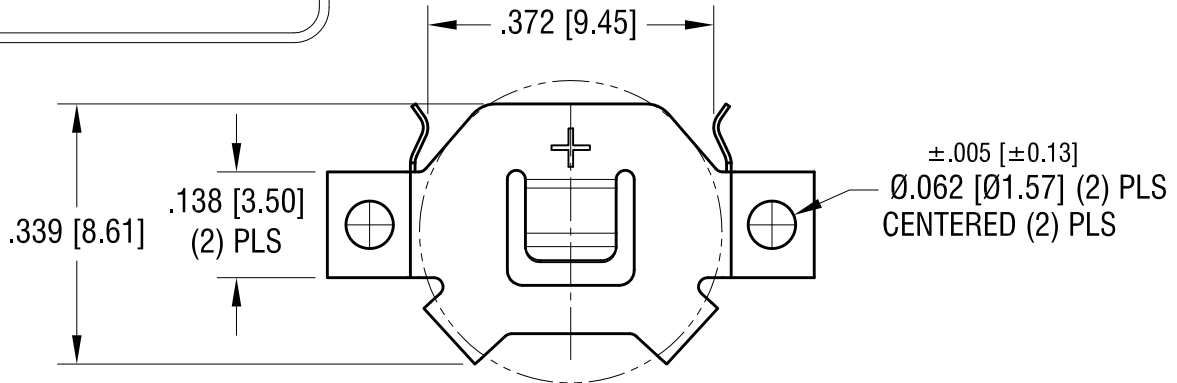

**SECTION A-A**

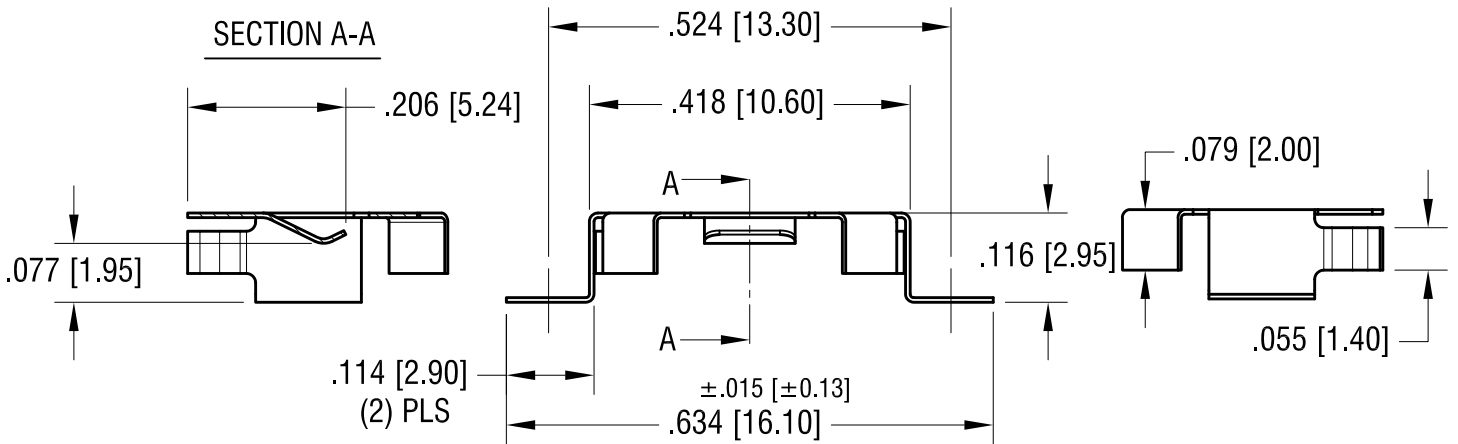

**KEYSTONE ELECTRONICS CORP.**

www.keyelco.com • ASTORIA, N.Y. 11105-2017 • Tel (718) 956-8900

PART NAME

10mm SM COIN CELL CLIP

MATERIAL

.006 [0.15] TH'K PHOSPHOR BRONZE

FINISH

TIN NICKEL PLATE

DRN BY

NT

DATE

9.17.10

APP'D

LN

SCALE

4X

5.07.15 CHANGE AS PER ECN 15-054

A

TOLERANCES INCH [MM]

DECIMAL  $\pm .010$  [ $\pm 0.25$ ]

ANGULAR  $\pm 1^\circ$

UNLESS OTHERWISE SPECIFIED

CODE

C

DWG NO.

3030

DATE

DESCRIPTION

REV.