

THIS DRAWING IS UNPUBLISHED. RELEASED FOR PUBLICATION 20
 © COPYRIGHT 20 BY - ALL RIGHTS RESERVED.

REVISIONS

P	LTR	DESCRIPTION	DATE	DWN	APVD
	A	INITIAL	06SEP2018	YC	CW

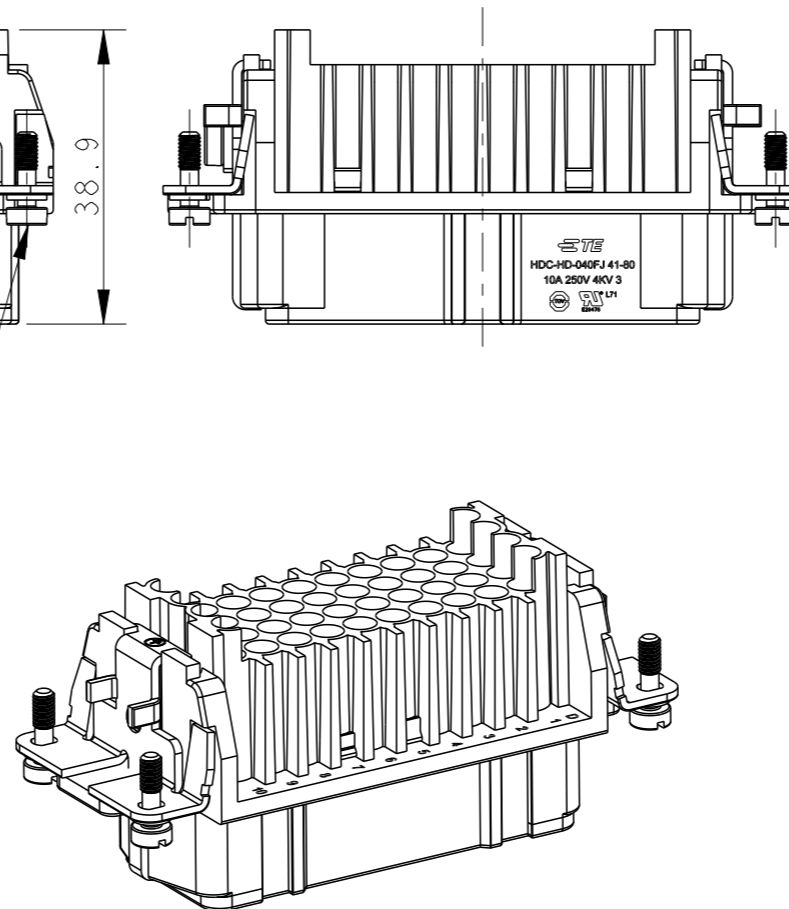
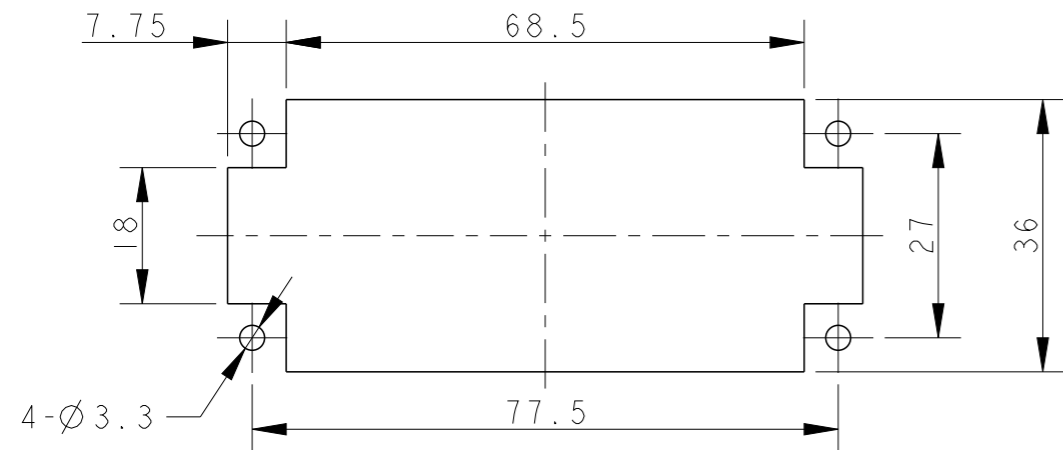
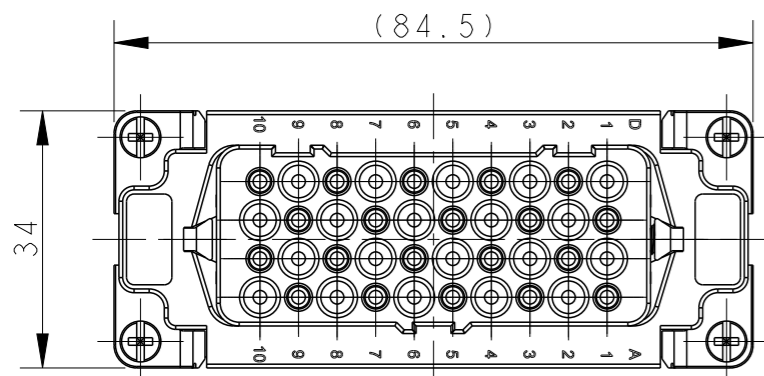
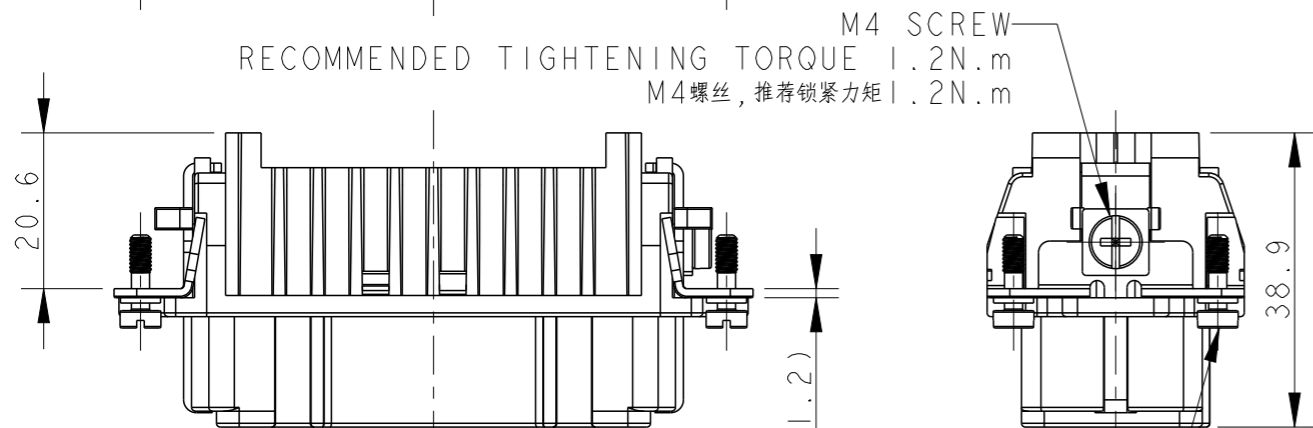
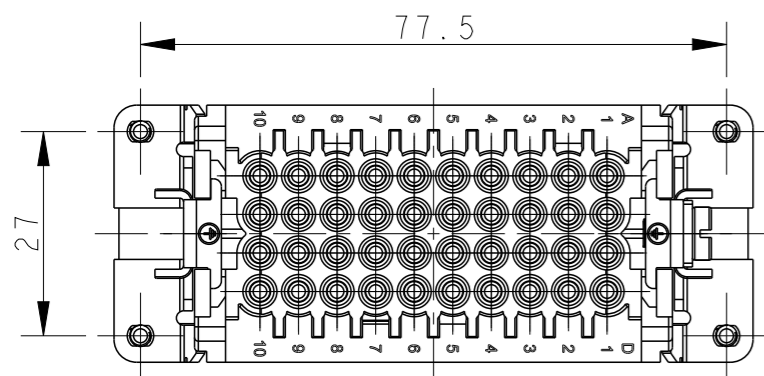

NOTES:

- TECHNICAL CHARACTERISTICS:
 INSULATION MATERIAL: PC
 RATED VOLTAGE: 250 V
 RATED CURRENT: 10 A
 INSULATION RESISTANCE: $\geq 400M\Omega$
 RATED IMPULSE VOLTAGE: 4 KV
 POLLUTION DEGREE: 3
 FLAMMABILITY: UL94V-0
 MATING CYCLES: 500 CYCLES
 WIRE RANGE: 0.14-2.5 mm² (26-14 AWG)
 CONTACT TYPE: CRIMP CONTACT
- CONTACT NEED TO BE ORDERED SEPARATELY.

注释:

- 技术参数:
 绝缘材料: PC
 额定电压: 250V
 额定电流: 10A
 绝缘电阻: $\geq 400M\Omega$
 额定脉冲电压: 4 KV
 污染等级: 3
 阻燃等级: UL94V-0
 插拔次数: 500次
 接线范围: 0.14-2.5 mm² (26-14 AWG)
 接线类型: 冷压接
- 端子需要单独订购.

T2020802201-100	HD-040-FJ 41-80	HD-040 FEMALE INSERT, STAMPING 41-80 HD-040母插, 卷皮针 41-80
PART NUMBER 料号	PART DESCRIPTION 描述	

THIS DRAWING IS A CONTROLLED DOCUMENT.		DWN 06SEP2018 YORK CHEN	 TE Connectivity NAME HD-040-FJ 41-80	RESTRICTED TO		
DIMENSIONS: mm		CHK 06SEP2018 GINO YAO		PRODUCT SPEC 108-137042	SIZE	CAGE CODE
TOLERANCES UNLESS OTHERWISE SPECIFIED:		APVD 06SEP2018 CHRIS WANG			114-137042	114-137042
0 PLC ±- 1 PLC ±- 2 PLC ±- 3 PLC ±- 4 PLC ±- ANGLES ±- MATERIAL - FINISH -		PRODUCT SPEC 108-137042		APPLICATION SPEC 114-137042	WEIGHT -	SCALE 1:1
CUSTOMER DRAWING			SIZE A3	CAGE CODE -	DRAWING NO. T2020802201100	
			SCALE 1:1	SHEET 1 OF 1	REV A	