

MECHANICAL DATA

**GOLD METALLISED
MULTI-PURPOSE SILICON
DMOS RF FET
150W – 28V – 400MHz
PUSH-PULL**

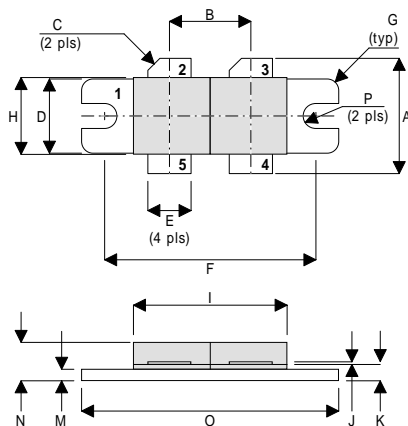

DR

PIN 1 SOURCE (COMMON) PIN 2 DRAIN 1
 PIN 3 DRAIN 2 PIN 4 GATE 2
 PIN 5 GATE 1

DIM	Millimetres	Tol.	Inches	Tol.
A	19.05	0.50	0.75	0.020
B	10.77	0.13	0.424	0.005
C	45°	5°	45°	5°
D	9.78	0.13	0.385	0.005
E	5.71	0.13	0.225	0.005
F	27.94	0.13	1.100	0.005
G	1.52R	0.13	0.060R	0.005
H	10.16	0.13	0.400	0.005
I	22.22	MAX	0.875	MAX
J	0.13	0.02	0.005	0.001
K	2.72	0.13	0.107	0.005
M	1.70	0.13	0.067	0.005
N	5.08	0.50	0.200	0.020
O	34.03	0.13	1.340	0.005
P	1.61R	0.08	0.064R	0.003

FEATURES

- EXTRA LOW C_{rss}
- SIMPLIFIED AMPLIFIER DESIGN
- SUITABLE FOR BROAD BAND APPLICATIONS
- SIMPLE BIAS CIRCUITS
- LOW NOISE
- HIGH GAIN – 10 dB MINIMUM

APPLICATIONS

- HF/VHF/UHF COMMUNICATIONS
from 1 MHz to 500 MHz

ABSOLUTE MAXIMUM RATINGS ($T_{case} = 25^{\circ}C$ unless otherwise stated)

P_D	Power Dissipation	389W
BV_{DSS}	Drain – Source Breakdown Voltage *	70V
BV_{GSS}	Gate – Source Breakdown Voltage *	±20V
$I_{D(sat)}$	Drain Current *	25A
T_{stg}	Storage Temperature	-65 to 150°C
T_j	Maximum Operating Junction Temperature	200°C

* Per Side

Semelab Plc reserves the right to change test conditions, parameter limits and package dimensions without notice. Information furnished by Semelab is believed to be both accurate and reliable at the time of going to press. However Semelab assumes no responsibility for any errors or omissions discovered in its use. Semelab encourages customers to verify that datasheets are current before placing orders.

ELECTRICAL CHARACTERISTICS (T_{case} = 25°C unless otherwise stated)

Parameter	Test Conditions	Min.	Typ.	Max.	Unit
PER SIDE					
B _V DSS	Drain–Source Breakdown Voltage	V _{GS} = 0 I _D = 100mA	70		V
I _D DSS	Zero Gate Voltage Drain Current	V _{DS} = 28V V _{GS} = 0		5	mA
I _G DSS	Gate Leakage Current	V _{GS} = 20V V _{DS} = 0		1	μA
V _{GS(th)}	Gate Threshold Voltage*	I _D = 10mA V _{DS} = V _{GS}	1	7	V
g _{fs}	Forward Transconductance*	V _{DS} = 10V I _D = 5A	4		S
TOTAL DEVICE					
G _{PS}	Common Source Power Gain	P _O = 150W	10		dB
η	Drain Efficiency	V _{DS} = 28V I _{DQ} = 2A	50		%
VSWR	Load Mismatch Tolerance	f = 400MHz	20:1		—
PER SIDE					
C _{iss}	Input Capacitance	V _{DS} = 28V V _{GS} = -5V f = 1MHz		300	pF
C _{oss}	Output Capacitance	V _{DS} = 28V V _{GS} = 0 f = 1MHz		150	pF
C _{rss}	Reverse Transfer Capacitance	V _{DS} = 28V V _{GS} = 0 f = 1MHz		10	pF

* Pulse Test: Pulse Duration = 300 μs , Duty Cycle ≤ 2%

HAZARDOUS MATERIAL WARNING

The ceramic portion of the device between leads and metal flange is beryllium oxide. Beryllium oxide dust is highly toxic and care must be taken during handling and mounting to avoid damage to this area.

THESE DEVICES MUST NEVER BE THROWN AWAY WITH GENERAL INDUSTRIAL OR DOMESTIC WASTE.

THERMAL DATA

R _{THj-case}	Thermal Resistance Junction – Case	Max. 0.45°C / W
-----------------------	------------------------------------	-----------------

Semelab Plc reserves the right to change test conditions, parameter limits and package dimensions without notice. Information furnished by Semelab is believed to be both accurate and reliable at the time of going to press. However Semelab assumes no responsibility for any errors or omissions discovered in its use. Semelab encourages customers to verify that datasheets are current before placing orders.

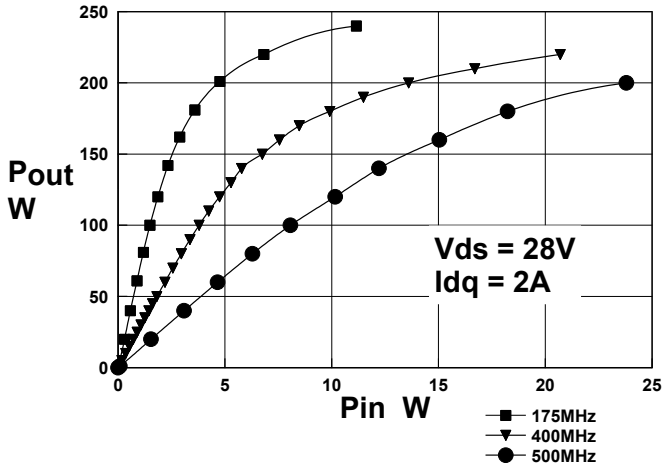

Figure 1. Output Power Vs Input Power

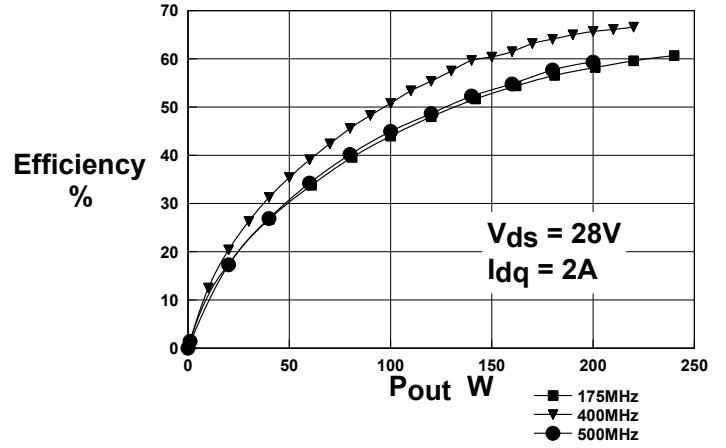

Figure 2. Efficiency Vs. Output Power

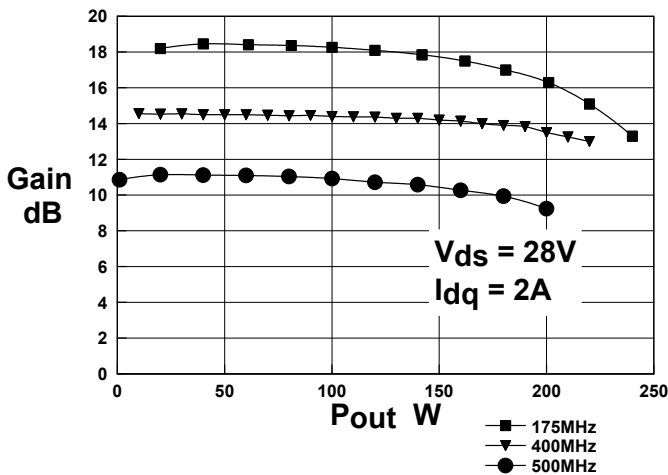

Figure 3. Gain Vs Output Power

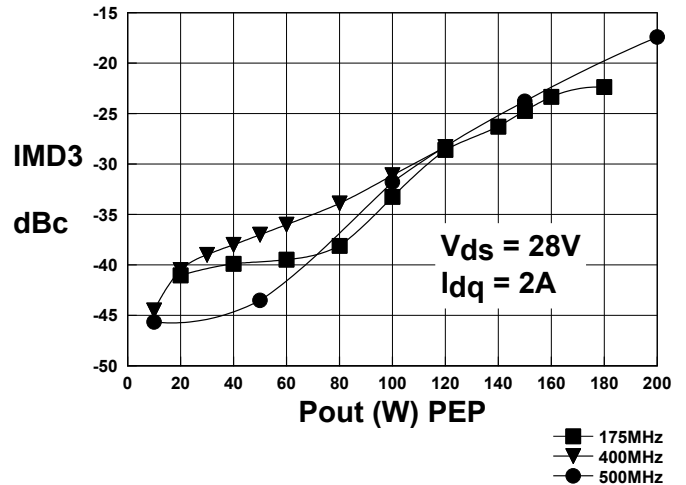

Figure 3. PEP vs. IMD 3

Typical S Parameters

!D1020UK.s2p
!Vds=28V,I_{dq}=2A
MHZ S MA R 50

Freq MHz	S11		S21		S12		S22	
	Mag	Ang	Mag	Ang	Mag	Ang	Mag	Ang
100	0.91	-176.9	5.45	62.1	0.006	8.3	0.80	-171.5
200	0.95	-179.2	1.99	40.1	0.006	59.9	0.89	-173.2
300	0.97	178.6	1.11	28.9	0.011	79.2	0.93	-175.9
400	0.98	176.0	0.65	20.6	0.017	83.6	0.96	-178.8
500	0.98	174.0	0.46	16.2	0.022	83.6	0.97	179.0
600	0.99	171.7	0.32	13.2	0.028	82.4	0.98	176.6
700	0.99	169.8	0.25	12.2	0.034	81.0	0.98	174.8
800	0.99	167.9	0.21	12.3	0.039	79.5	0.98	173.1
900	0.99	165.6	0.17	13.7	0.046	77.6	0.99	171.1
1000	0.99	163.7	0.15	15.9	0.052	76.0	0.99	169.4

Semelab Plc reserves the right to change test conditions, parameter limits and package dimensions without notice. Information furnished by Semelab is believed to be both accurate and reliable at the time of going to press. However Semelab assumes no responsibility for any errors or omissions discovered in its use. Semelab encourages customers to verify that datasheets are current before placing orders.

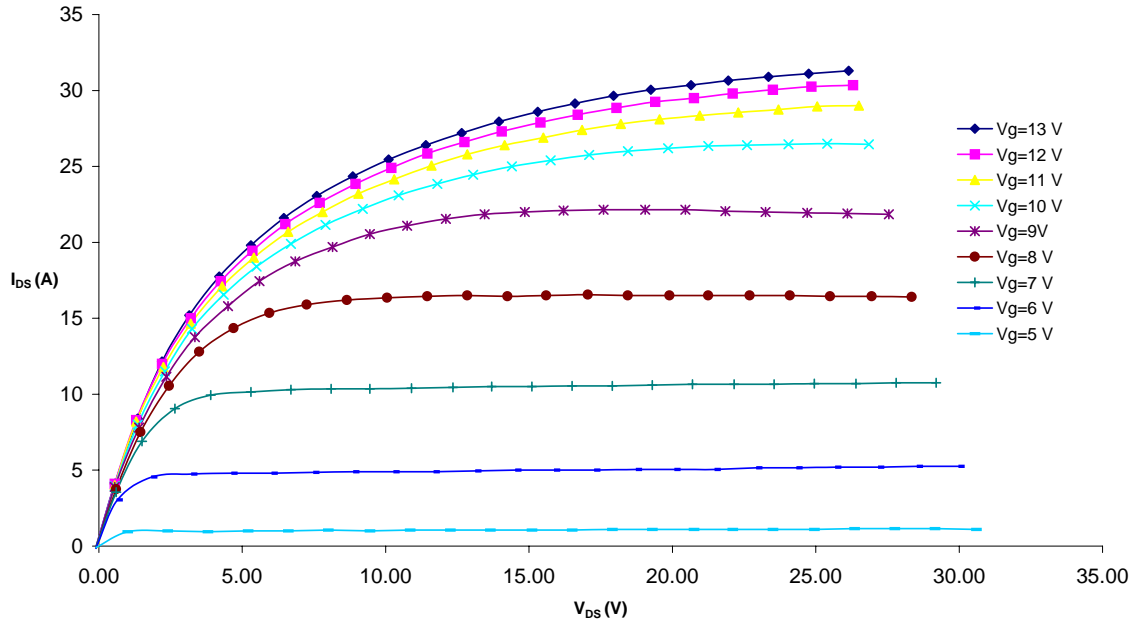

Figure 4 – Typical IV Characteristics.

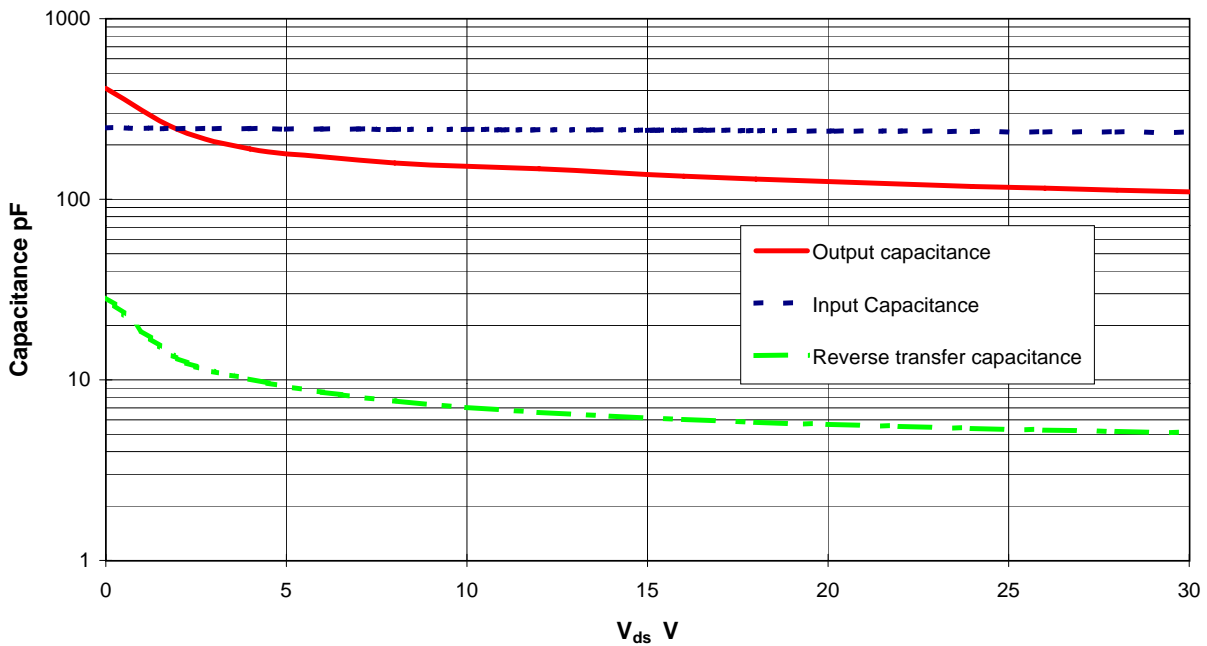
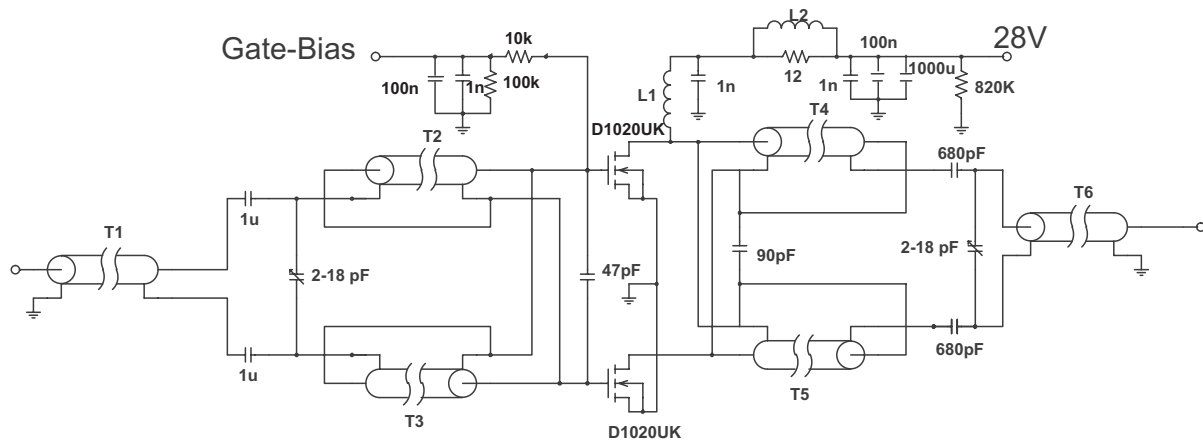

Figure 5 – Typical CV Characteristics.

Semelab Plc reserves the right to change test conditions, parameter limits and package dimensions without notice. Information furnished by Semelab is believed to be both accurate and reliable at the time of going to press. However Semelab assumes no responsibility for any errors or omissions discovered in its use. Semelab encourages customers to verify that datasheets are current before placing orders.



175 MHz Test Fixture

- T1,2,3 7cm Storm Products EXE 18 19/30 S1TW coaxial cable on Siemens A1 x 1 2 hole core
- T4,5 14cm Storm products EXE18 19/30 S1TW coaxial cable
- T6 11cm Storm products EXE 18 19/30 S1TW coaxial cable
- L1 6 turns 1.2mm dia wire, 5mm internal diameter
- L2 1.5 turns 0.9mm dia wire on Siemens A1 x 1 2 hole core

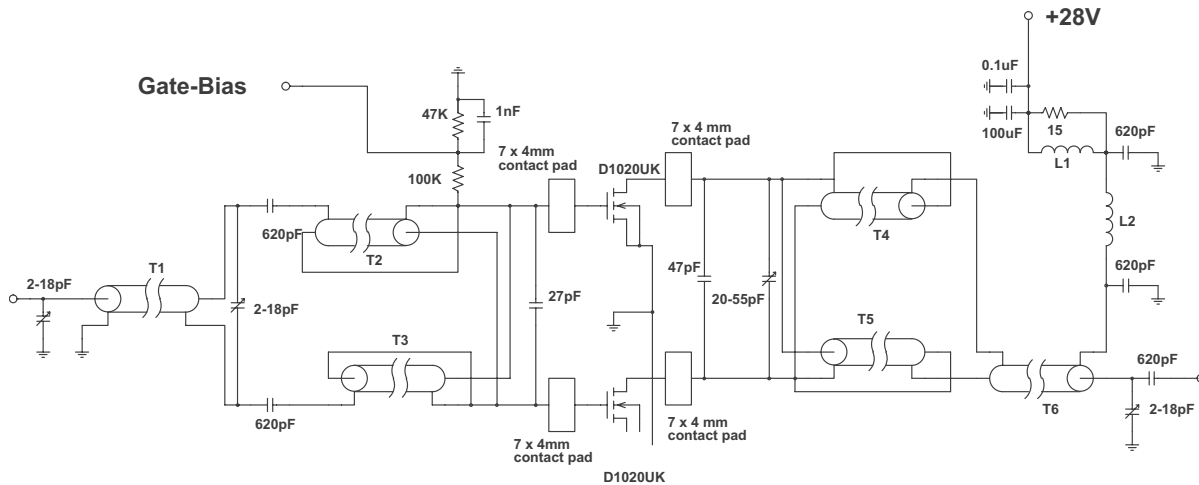

400 MHz Test Fixture

- T1 11cm 50 Ohm UT47 semi-rigid coax
- T2,3,4,5 8.9cm 18 Ohm UT62-18 semi-rigid coax
- T6 9.4cm 50 Ohm UT85 semi-rigid coax
- L1 5.5 turns 18swg enamelled copper wire on Fair-Rite FT50B-43 ferrite core
- L2 6 turns 18swg enamelled copper wire, 3.5mm internal diameter

Semelab Plc reserves the right to change test conditions, parameter limits and package dimensions without notice. Information furnished by Semelab is believed to be both accurate and reliable at the time of going to press. However Semelab assumes no responsibility for any errors or omissions discovered in its use. Semelab encourages customers to verify that datasheets are current before placing orders.

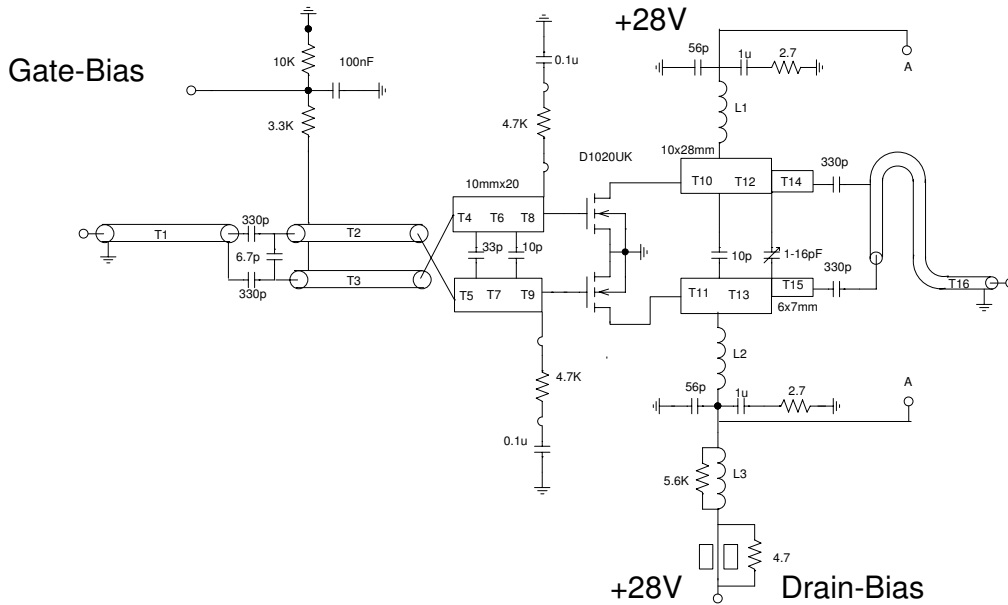

D1020UK 500MHz TEST FIXTURE

Substrate 0.78mm, Er=3.3

All microstrip lines W=10mm unless otherwise stated

T1 70mm 50 Ohm Coaxial cable	T5 3.8mm	T9 5.6mm	T13 14mm
T2 50mm 25 Ohm Coaxial cable	T6 10.6mm	T10 14mm	T14 7mm width 6mm height
T3 50mm 25 Ohm Coaxial cable	T7 10.6mm	T11 14mm	T15 7mm width 6mm height
T4 3.8mm	T8 5.6mm	T12 14mm	T16 80mm 50 Ohm Coaxial Cable

L1 = L2 3 turns 1mm diameter enamelled copper wire, 5mm i.d.

Mouser Electronics

Authorized Distributor

Click to View Pricing, Inventory, Delivery & Lifecycle Information:

[TT Electronics:](#)

[D1020UK](#)