



Made in the  
United States of America

# Training Paddles Usage Instructions

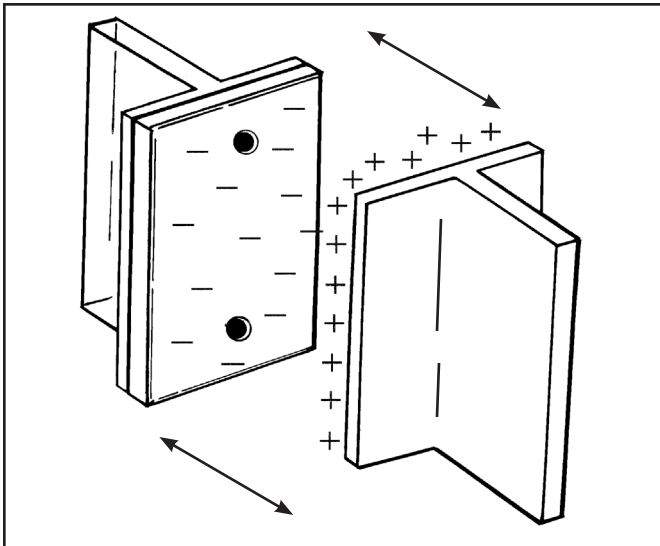

Figure 1. Desco [06850](#) ESD Training Paddles

## Description

Desco ESD Training Paddles are ideal for demonstrating several electrostatic principles. Among these are:

- Static Electric Fields
- Polarity
- Field Suppression
- Neutralization
- Field Induction
- Field Induced Discharges

These paddles are portable and can easily generate a static electric field strength of a few kilovolts. The paddle kit consists of one insulative plate and one conductive plate; both plates are isolated with an insulative handle.

## Materials and Equipment Needed:

To take full advantage of your training paddles you'll need a static field meter, a grounded ESD mat with common point ground (extra banana jacks), an air ionizer, an insulative work surface (regular plastic, cardboard, glass, etc.) and a wrist strap. Note: you can add or substitute an ionization test kit or charge plate analyzer for the static field meter.

## Packaging

- 1 Aluminum, 3" x 4" inch paddle with acrylic handle.
- 1 Acrylic, 3" x 4" paddle with acrylic handle.

## Experiment 1: Static Electric Fields

Bring the bottom of both paddles together and rotate the handles to start the tribocharge process on the paddle plates. See figure 2.

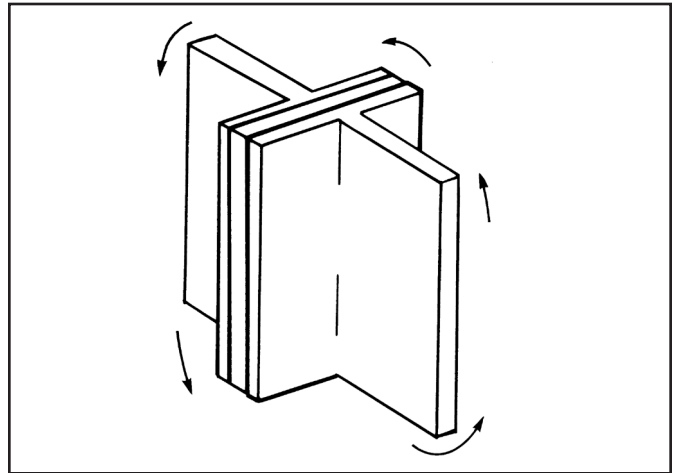

Figure 2. Rotate paddles together to tribocharge.

Separate the plates paddles, thereby generating an electrical charge, and set the acrylic paddle down for now. Using a static field meter and following the manufacturers operating instructions, hold the meter up to the aluminum paddle at the proper distance (refer to field meter to determine the proper distance between the meter sensor and the paddle typically 1"). Measure the electrical field. See figure 3.

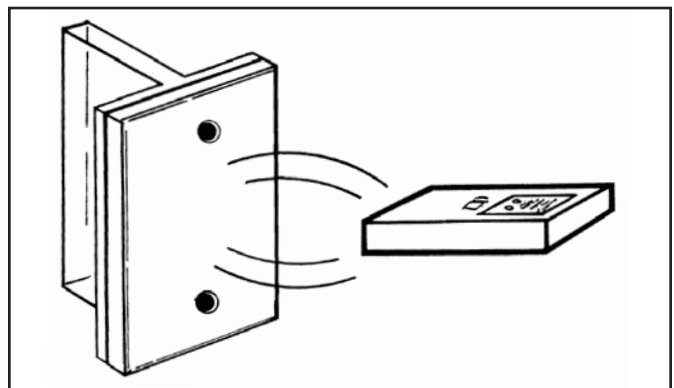

Figure 3. Measure plate with static field meter. (Note: Most static field meters measure direct readings at 1 inch.)

This measurement is expressed in volts by the meter. Next, place the aluminum paddle down on an insulative surface and repeat the process on the insulative paddle. Now, measure the conductive paddle again. Note that not only does the insulative acrylic

paddle generate and hold a charge, but the isolated conductive paddle does as well. The acrylic and the conductive paddles will have different field strengths. Note: When measuring fields, be careful not to touch the conductive plate so as not to accidentally dissipate the charge.

### Experiment 2: Polarity

Note that the charge on one paddle will be positive and the charge on the other will be negative. Electrostatic charge is generated by contact and separation of two surfaces where one surface loses electrons and the other surface gains electrons. The surface that loses electrons will have a net positive charge while the surface that gains electrons will have a net negative charge.

### Experiment 3: Field Suppression

Bring the bottom of both paddles together and rotate the handles to tribocharge the paddle plates. Separate the paddles, placing the insulative acrylic paddle on the table and measure the field from the conductive plate (aluminum) with a static field meter. Now place the conductive paddle face down onto the grounded ESD mat. Wait a few seconds and re-measure the field on the conductive paddle. Note that the field has been reduced or the charge imbalance has been restored to a balanced state. (If you still measure a large charge, then the mat isn't dissipative/conductive or is not properly grounded.)

Then place the insulative paddle face down on the grounded ESD mat. Take your static field meter and measure the charge on the outside of the plate as it is still face down on the ESD mat. Note that the field has been reduced (to near zero). The free electrons in the conductive mat have balanced the charge imbalance on the insulative paddle nullifying the electric field. Now pick up the paddle and re-measure the field on the acrylic plate. Note that the field is still there. The field is still present because the charge was removed to ground. The material is insulative and restricts the flow of free electrons so the charge cannot be removed to ground. The act of hiding the electric field by temporarily balancing it off is called charge suppression. Charge suppression means that electrostatic charges can be difficult to detect.

### Experiment 4: Neutralization

Bring the bottom of both paddles together and rotate the handles to tribocharge the paddle plates. Separate the paddles, set aside the conductive paddle and measure the insulative face of the acrylic paddle with a static field meter. Note the field strength of the reading. Place the insulative paddle in the airflow of your ionizer. Wait about 5 seconds and then remove the paddle from the ionized air flow and measure the insulated face (plate) of the paddle. Note that the field strength had been reduced to just several tens of Volts and not kilovolts. This is the only way to reduce the

charge imbalance on an insulator, such as a circuit board.

### Experiment 5: Field Induction

Bring the bottom of both paddles together and rotate the handles to initiate the tribocharge generation of the paddle plates. Separate the paddles, and measure the conductive paddle face with a static field meter. Note the field strength and polarity. Repeat field measurement with the insulative paddle. Now place the conductive paddle face down onto the ESD mat, effectively grounding away any charge generated. Remove the conductive paddle from the mat. Next, pass the charged insulative paddle to within approximately 1/2" of the conductive paddle and set the insulative paddle down. Now, use your static field meter to measure the conductive paddle again. A measurable charge will have been induced onto the conductive paddle, hence field induction. When conducting this experiment it is important not to ground the conductive paddles.

### Experiment 6: Field Induced Discharges

The biggest threat is Field Induced Discharges, which can occur even at a properly grounded ESD mat. If an ESD sensitive (ESDS) item is grounded in the presence of an ElectroStatic charge, instead of the ESDS item having charges removed from it, the ESDS item may become charged with a voltage induced on it. Then, when placed on the grounded ESD mat, a discharge occurs. If the ESDS item is removed from the presence of the ElectroStatic charge and grounded again, a second discharge may occur. (Ref. ESD Handbook, ESD TR20.20, section 2.7.5).

In Experiment 3, we have demonstrated that a charge is removed from the aluminum paddle after making contact with the grounded ESD mat. Repeat, but next to a charged acrylic paddle, and a charge will be placed on the aluminum paddle.

### Usage

These paddles are to be used as training aids in demonstrating electrostatic principles. We do not warrant paddles for any other application or usage.

### Specifications

Paddle Size:	3" x 4", each paddle
Total Weight:	~0.65 pounds per pair
Conductive Plate:	Aluminum, 3" x 4" x 1/8"
Insulative Plate:	Acrylic, 3" x 4" x 1/8"
Color:	Silver and transparent
Charge generation:	1kV to 6kV

#### Limited Warranty, Warranty Exclusions, Limit of Liability and RMA Request Instructions

See Desco's Terms and Conditions -

<http://desco.descoindustries.com/TermsAndConditions.aspx>