

## High Voltage Series Non-Magnetic Trimmer Capacitors



Part Number	Capacitance (pF)		Q (Min) 100 MHz	DC Working Voltage	DC Withstanding Voltage	Dielectric	Fig.	"A" Dim. ± .016	"B" Dim. ± .016
	From Below	To Above							
NMNT1-20*	0.1	1	2000	10000	20000	PTFE	<u>1</u>	1.185	1.125
NMNT5-8	0.8	5	2000	4000	8000	PTFE	<u>3</u>	—	—
NMNT5-25	0.5	5	1800	12500	25000	PTFE	<u>1</u>	2	0.75
NMNT10-3	1	10	3500	1500	3000	PTFE	<u>2</u>	1.69	0.31
NMNT10-4	1	10	3500	2000	4000	PTFE	<u>2</u>	1.69	0.31
NMNT10-6	1	10	2000	3000	6000	PTFE	<u>1</u>	1.15	0.38
NMNT10-7	1	10	2000	3500	7000	PTFE	<u>1</u>	1.85	0.38
NMNT10-12	2	10	1800	6000	12000	PTFE	<u>1</u>	1.83	0.63
NMNT15	1	15	2000	2000	4000	PTFE	<u>2</u>	1.69	0.31
NMNT20-9	3	20	2300	4500	9000	PTFE	<u>1</u>	1.24	0.63
NMNT23-6	3	23	2200	3000	6000	PTFE	<u>1</u>	1.7	0.38
NMNT25-6	5	25	2000	3000	6000	PTFE	<u>1</u>	1.62	0.63
NMNT25-12	7	25	1500	6000	12000	PTFE	<u>1</u>	1.77	1.13
NMNT30	4	30	1200	3000	6000	PTFE	<u>1</u>	2.25	1.5
NMNT50	5	50	700	4500	9000	PTFE	<u>1</u>	2.25	1.5
NMNT70-6	2.5	70	650	3000	6000	PTFE	<u>1</u>	3	0.7
NMNT70-15	6.5	70	650	7500	15000	PTFE	<u>1</u>	3.25	1.63
NMNT75-5	1	75	650	2500	5000	PTFE	<u>1</u>	2.8	0.8
NMNT75-8	1	75	650	4000	8000	PTFE	<u>1</u>	2.8	0.8
NMNT85	5	85	600	3000	6000	PTFE	<u>1</u>	3.25	1.5

\*NO LEAD

# High Voltage Series Non-Magnetic Trimmer Capacitors

FIG. 1

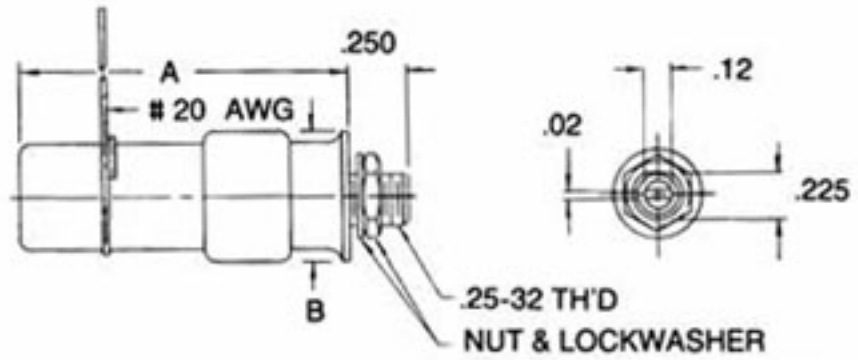

FIG. 2

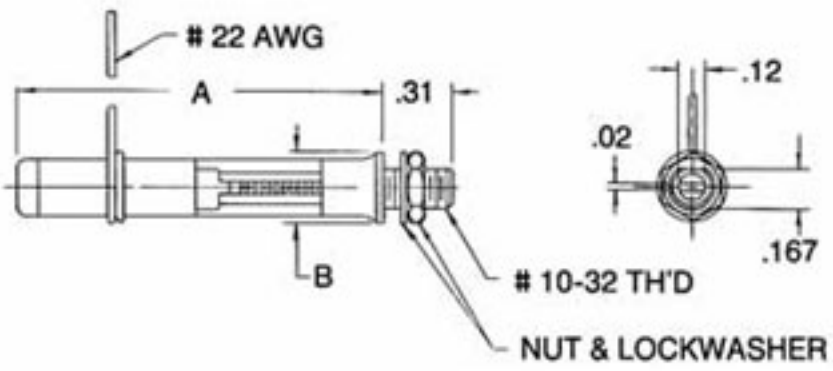
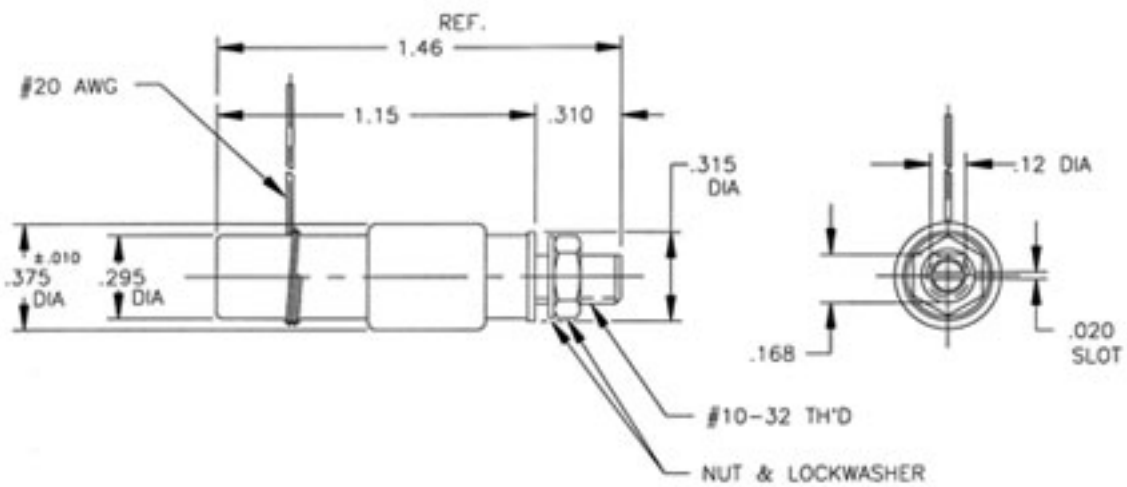

FIG. 3



## Extended Shaft Option

Add "E" to end of part number