



GaAs INTEGRATED CIRCUIT

μ PG2251T6M

+25 dBm MATCHED POWER AMPLIFIER FOR Bluetooth™ Class 1

DESCRIPTION

The μ PG2251T6M is a fully matched, +25 dBm GaAs MMIC power amplifier for Bluetooth Class 1.

This device realizes high efficiency, high gain and high output power.

This device is housed in a 12-pin plastic TSQFN (Thin Small Quad Flat Non-leaded) (T6M) package, and is suitable for high-density surface mounting.

FEATURES

- Operating frequency : $f_{opt} = 2\ 400$ to $2\ 500$ MHz (2 450 MHz TYP.)
- Supply voltage : $V_{DD1, 2, 3} = 2.5$ to 3.5 V (3.0 V TYP.)
- Control voltage : $V_{cont} = 1.5$ to 2.1 V (1.8 V TYP.)
- Circuit current : $I_{DD} = 230$ mA TYP. @ $V_{DD1, 2, 3} = 3.0$ V, $V_{cont} = 1.8$ V, $P_{out} = +25$ dBm
- Output power : $P_{out} = +25.0$ dBm TYP. @ $V_{DD1, 2, 3} = 3.0$ V, $V_{cont} = 1.8$ V, $P_{in} = -5$ dBm
- Gain control range : GCR = 70 dB TYP. @ $V_{DD1, 2, 3} = 3.0$ V, $V_{cont} = 0$ to 1.8 V, $P_{in} = -5$ dBm
- High efficiency : PAE = 47% TYP. @ $V_{DD1, 2, 3} = 3.0$ V, $V_{cont} = 1.8$ V, $P_{in} = -5$ dBm
- High-density surface mounting : 12-pin plastic TSQFN (T6M) package ($2.0 \times 2.0 \times 0.37$ mm)

APPLICATIONS

- Power Amplifier for Bluetooth Class 1, ZigBee™ etc.

ORDERING INFORMATION

Part Number	Order Number	Package	Marking	Supplying Form
μ PG2251T6M-E2	μ PG2251T6M-E2-A	12-pin plastic TSQFN (T6M) (Pb-Free)	2251	<ul style="list-style-type: none">• Embossed tape 8 mm wide• Pin 10, 11, 12 face the perforation side of the tape• Qty 3 kpcs/reel

Remark: To order evaluation samples, please contact your nearby sales office.

Part number for sample order: μ PG2251T6M-A

Caution: Observe precautions when handling, because these devices are sensitive to electrostatic discharge.

The information in this document is subject to change without notice. Before using this document, please confirm that this is the latest version.

PIN CONNECTIONS AND INTERNAL BLOCK DIAGRAM

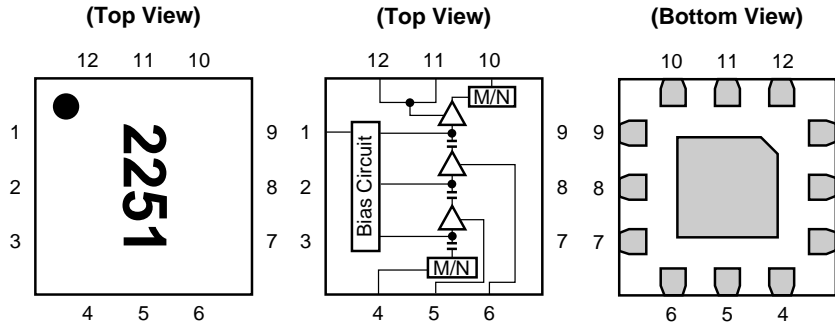

Pin No.	Pin Name
1	V _{cont}
2	GND
3	GND
4	P _{in}
5	V _{DD1}
6	V _{DD2}
7	GND
8	GND
9	GND
10	P _{out}
11	V _{DD3}
12	V _{DD3}

Remark Exposed pad : GND

ABSOLUTE MAXIMUM RATINGS (T_A = +25°C, unless otherwise specified)

Parameter	Symbol	Ratings	Unit
Supply Voltage	V _{DD1, 2, 3}	6.0	V
Control Voltage	V _{cont}	3.0	V
Circuit Current	I _{DD}	300	mA
Control Current	I _{cont}	0.5	mA
Input Power	P _{in}	+10	dBm
Power Dissipation	P _D	600 ^{Note}	mW
Operating Ambient Temperature	T _A	-40 to +85	°C
Storage Temperature	T _{stg}	-55 to +150	°C

Note Mounted on double-sided copper-clad 50 × 50 × 1.6 mm epoxy glass PWB, T_A = +85°C

RECOMMENDED OPERATING RANGE (T_A = +25°C, unless otherwise specified)

Parameter	Symbol	MIN.	TYP.	MAX.	Unit
Operating Frequency	f _{opt}	2 400	2 450	2 500	MHz
Supply Voltage	V _{DD1, 2, 3}	2.5	3.0	3.5	V
Control Voltage	V _{cont}	1.5	1.8	2.1	V

ELECTRICAL CHARACTERISTICS ($T_A = +25^\circ\text{C}$, $V_{DD1, 2, 3} = 3.0\text{ V}$, $V_{cont} = 1.8\text{ V}$, $f = 2.4\text{ to }2.5\text{ GHz}$, unless otherwise specified)

Parameter	Symbol	Test Conditions	MIN.	TYP.	MAX.	Unit
Circuit Current	I_{DD}	$P_{in} = -5\text{ dBm}$	-	230	265	mA
Output Power 1	P_{out1}	$P_{in} = -5\text{ dBm}$	+23	+25	-	dBm
Output Power 2	P_{out2}	$V_{cont} = 0\text{ V}$, $P_{in} = -5\text{ dBm}$	-	-45	-30	dBm
Gain Control Range	GCR	$V_{cont} = 0\text{ to }1.8\text{ V}$, $P_{in} = -5\text{ dBm}$	-	70	-	dB
Efficiency	PAE	$P_{in} = -5\text{ dBm}$	-	47	-	%
2nd Harmonics	2f0	$P_{in} = -5\text{ dBm}$	-	-35	-	dBc
3rd Harmonics	3f0	$P_{in} = -5\text{ dBm}$	-	-30	-	dBc
Input Return Loss	RL_{in}	$P_{in} = -30\text{ dBm}$	-	-5	-	dB
Output Return Loss	RL_{out}	$P_{in} = -30\text{ dBm}$	-	-10	-	dB

EVALUATION CIRCUIT

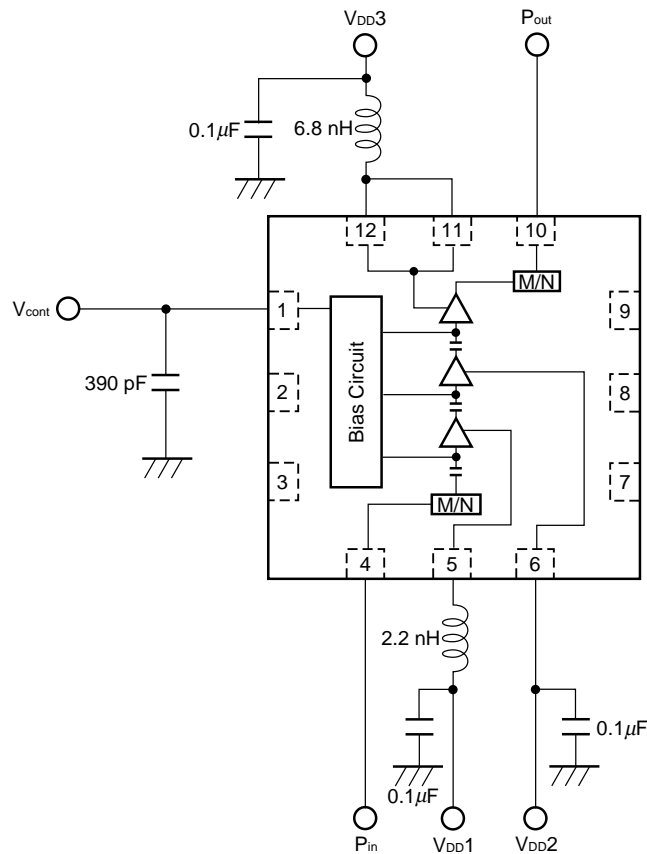

The application circuits and their parameters are for reference only and are not intended for use in actual design-ins.

TYPICAL CHARACTERISTICS ($T_A = +25^\circ\text{C}$, $V_{DD1, 2, 3} = 3.0\text{ V}$, $V_{cont} = 1.8\text{ V}$, $f = 2.45\text{ GHz}$, unless otherwise specified)

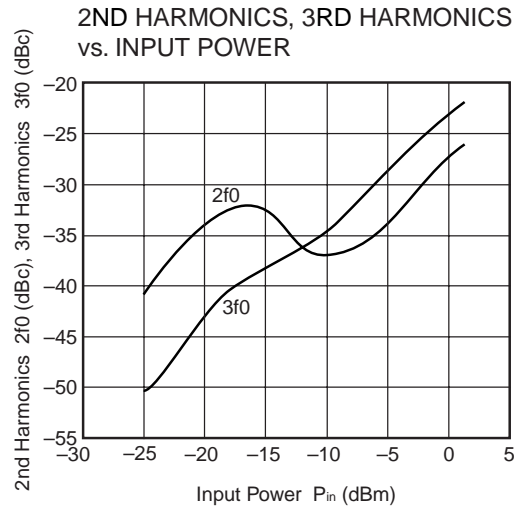
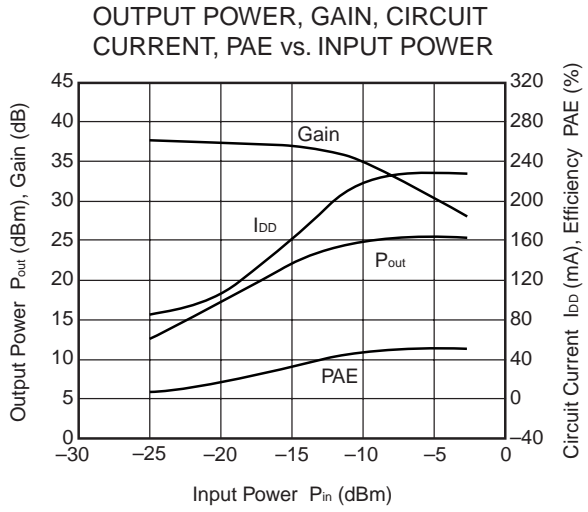

Remark The graphs indicate nominal characteristics.

S-PARAMETERS

Condition : $T_A = +25^\circ\text{C}$, $V_{DD1, 2, 3} = 3.0\text{ V}$, $V_{cont} = 1.8\text{ V}$, $P_{in} = -30\text{ dBm}$

S₁₁-FREQUENCY

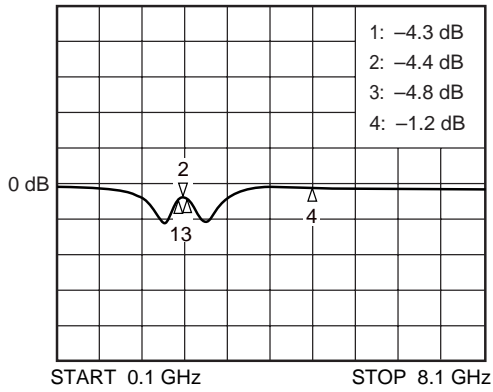

S₁₂-FREQUENCY

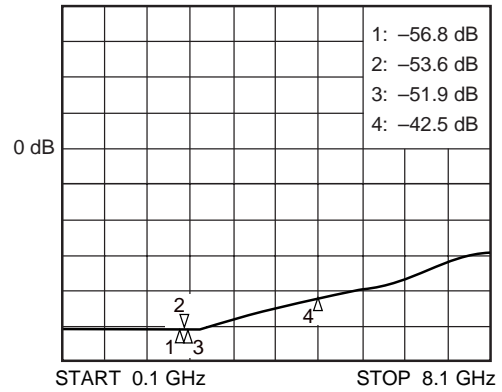

S₂₁-FREQUENCY

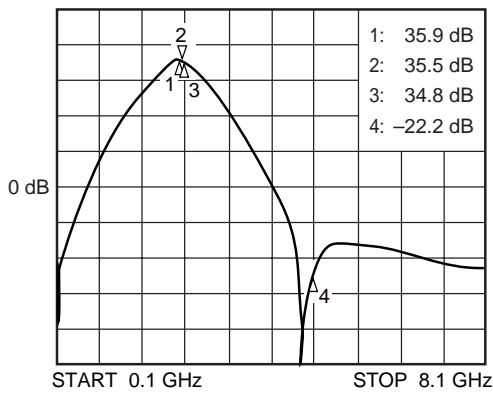

S₂₂-FREQUENCY

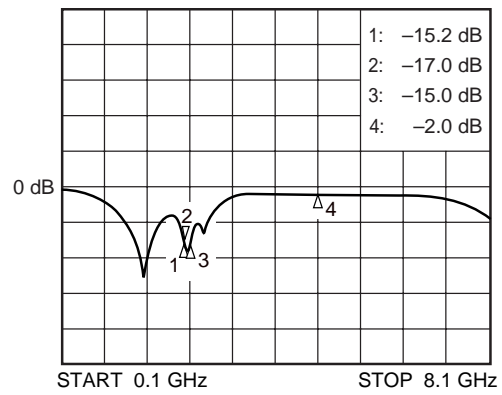

Remarks 1. The graphs indicate nominal characteristics.

2. Marker 1 : 2.4 GHz, 2 : 2.45 GHz, 3 : 2.5 GHz, 4 : 4.9 GHz

MOUNTING PAD LAYOUT DIMENSIONS

12-PIN PLASTIC TSQFN (T6M) (UNIT: mm)

MOUNTING PAD

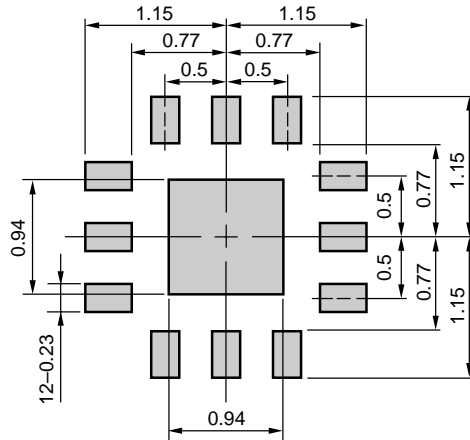

Remark The mounting pad layout in this document is for reference only.
 When designing PCB, please consider workability of mounting, solder joint reliability, prevention of solder bridge and so on, in order to optimize the design.

PACKAGE DIMENSIONS

12-PIN PLASTIC TSQFN (T6M) (UNIT: mm)

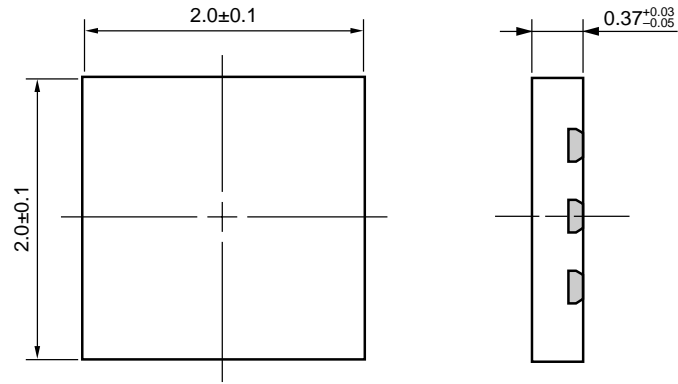

(Bottom View)

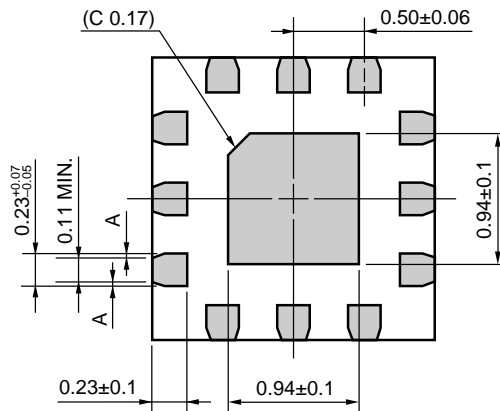

Remark $A > 0$

(): Reference value

RECOMMENDED SOLDERING CONDITIONS

This product should be soldered and mounted under the following recommended conditions. For soldering methods and conditions other than those recommended below, contact your nearby sales office.

Soldering Method	Soldering Conditions	Condition Symbol
Infrared Reflow	Peak temperature (package surface temperature)	: 260°C or below
	Time at peak temperature	: 10 seconds or less
	Time at temperature of 220°C or higher	: 60 seconds or less
	Preheating time at 120 to 180°C	: 120±30 seconds
	Maximum number of reflow processes	: 3 times
	Maximum chlorine content of rosin flux (% mass)	: 0.2%(Wt.) or below
Partial Heating	Peak temperature (terminal temperature)	: 350°C or below
	Soldering time (per side of device)	: 3 seconds or less
	Maximum chlorine content of rosin flux (% mass)	: 0.2%(Wt.) or below

Caution Do not use different soldering methods together (except for partial heating).

Bluetooth is a trademark owned by Bluetooth SIG, Inc., U.S.A.

ZigBee is a trademark of Koninklijke Philips Electronics N.V.

- The information in this document is current as of October, 2009. The information is subject to change without notice. For actual design-in, refer to the latest publications of NEC Electronics data sheets, etc., for the most up-to-date specifications of NEC Electronics products. Not all products and/or types are available in every country. Please check with an NEC Electronics sales representative for availability and additional information.

- No part of this document may be copied or reproduced in any form or by any means without the prior written consent of NEC Electronics. NEC Electronics assumes no responsibility for any errors that may appear in this document.

- NEC Electronics does not assume any liability for infringement of patents, copyrights or other intellectual property rights of third parties by or arising from the use of NEC Electronics products listed in this document or any other liability arising from the use of such products. No license, express, implied or otherwise, is granted under any patents, copyrights or other intellectual property rights of NEC Electronics or others.

- Descriptions of circuits, software and other related information in this document are provided for illustrative purposes in semiconductor product operation and application examples. The incorporation of these circuits, software and information in the design of a customer's equipment shall be done under the full responsibility of the customer. NEC Electronics assumes no responsibility for any losses incurred by customers or third parties arising from the use of these circuits, software and information.

- While NEC Electronics endeavors to enhance the quality and safety of NEC Electronics products, customers agree and acknowledge that the possibility of defects thereof cannot be eliminated entirely. In addition, NEC Electronics products are not taken measures to prevent radioactive rays in the product design. When customers use NEC Electronics products with their products, customers shall, on their own responsibility, incorporate sufficient safety measures such as redundancy, fire-containment and anti-failure features to their products in order to avoid risks of the damages to property (including public or social property) or injury (including death) to persons, as the result of defects of NEC Electronics products.

- NEC Electronics products are classified into the following three quality grades: "Standard", "Special" and "Specific".

The "Specific" quality grade applies only to NEC Electronics products developed based on a customer-designated "quality assurance program" for a specific application. The recommended applications of an NEC Electronics product depend on its quality grade, as indicated below. Customers must check the quality grade of each NEC Electronics product before using it in a particular application.

"Standard": Computers, office equipment, communications equipment, test and measurement equipment, audio and visual equipment, home electronic appliances, machine tools, personal electronic equipment and industrial robots.

"Special": Transportation equipment (automobiles, trains, ships, etc.), traffic control systems, anti-disaster systems, anti-crime systems, safety equipment and medical equipment (not specifically designed for life support).

"Specific": Aircraft, aerospace equipment, submersible repeaters, nuclear reactor control systems, life support systems and medical equipment for life support, etc.

The quality grade of NEC Electronics products is "Standard" unless otherwise expressly specified in NEC Electronics data sheets or data books, etc. If customers wish to use NEC Electronics products in applications not intended by NEC Electronics, they must contact an NEC Electronics sales representative in advance to determine NEC Electronics' willingness to support a given application.

(Note)

(1) "NEC Electronics" as used in this statement means NEC Electronics Corporation and also includes its majority-owned subsidiaries.

(2) "NEC Electronics products" means any product developed or manufactured by or for NEC Electronics (as defined above).

M8E0904E

Caution	GaAs Products	<p>This product uses gallium arsenide (GaAs). GaAs vapor and powder are hazardous to human health if inhaled or ingested, so please observe the following points.</p> <ul style="list-style-type: none">• Follow related laws and ordinances when disposing of the product. If there are no applicable laws and/or ordinances, dispose of the product as recommended below.<ol style="list-style-type: none">1. Commission a disposal company able to (with a license to) collect, transport and dispose of materials that contain arsenic and other such industrial waste materials.2. Exclude the product from general industrial waste and household garbage, and ensure that the product is controlled (as industrial waste subject to special control) up until final disposal.• Do not burn, destroy, cut, crush, or chemically dissolve the product.• Do not lick the product or in any way allow it to enter the mouth.
----------------	---------------	--