

LOC A1	DIST —	REVISIONS ÄNDERUNGEN DESCRIPTION BESCHREIBUNG			DATE	DWN	APVD
		P	LTR				
		A3		REVISED PER ECR-09-018681	20AUG09	VKH	RRP

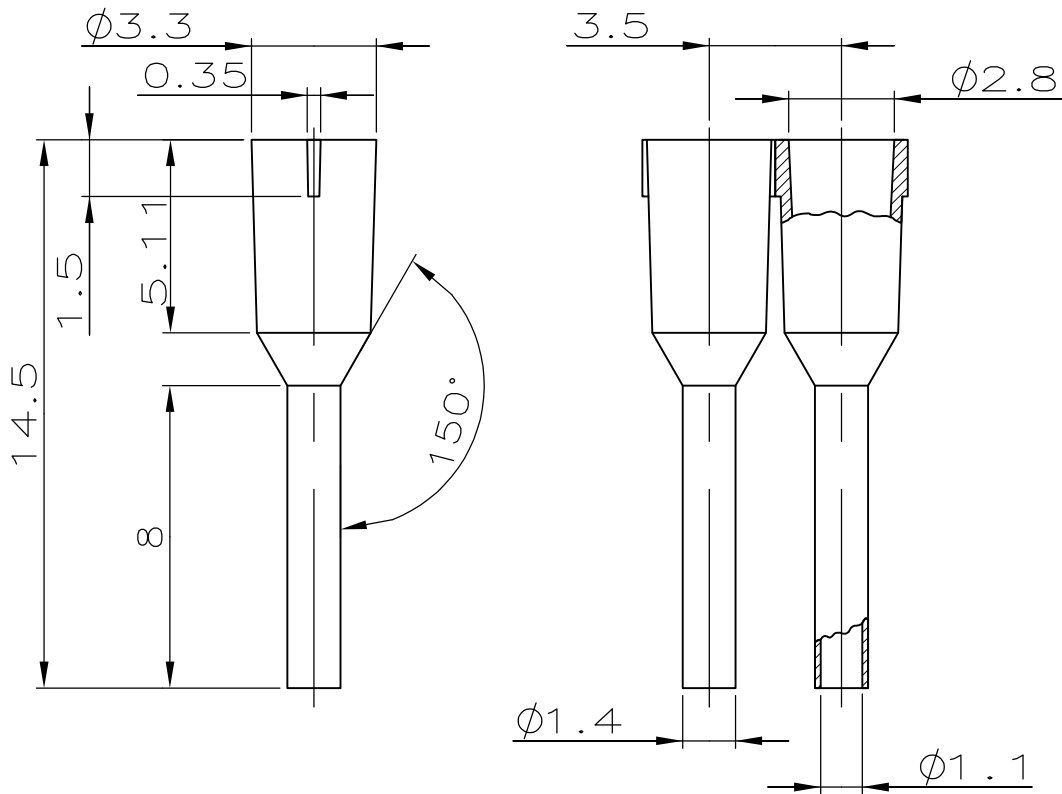

ACCORDING TO DIN 46228 PART 4  
ENTSPRICHT DIN 46228 TEIL 4

REMARKS:  
Bemerkungen

- 1 PACKING UNIT: 1000 PIECES ON REEL  
VERPACKUNGSEINHEIT: 1000 STUECK AUF SPULE
- 2 MAX. INSULATION-DIA. OF WIRE:  $\phi 2.4\text{mm}$   
MAX. ISOLATIONS- $\phi$  DER LEITUNG:  $\phi 2.4\text{mm}$
- 3 USE STRIPPER-CRIMPER MACHINE 528343-1  
BENUTZEN SIE STRIPPER-CRIMPER MASCHINE 528343-1

THIS DRAWING IS UNPUBLISHED.  
 VERTRÄGLICHE UNVERÖFFENTLICHTE ZEICHNUNG.  
 © COPYRIGHT - BY TYCO ELECTRONICS CORPORATION. ALL INTERNATIONAL RIGHTS RESERVED. ALLE RECHTE VORBEHALTEN.

WHITE	1241000-1	1
COLOR	PART NUMBER	NO.

DIMENSIONS: MASSENHEITEN mm	DWN R. Schmidt	17-DEC-97	MATERIAL PP/E-Cu	FINISH OBERFLAECHE/FARBE	Sn
	CHK W.Boeck	16-JAN-98	Tyco Electronics AMP GmbH D - 63225 Langen		
TOLERANCES UNLESS OTHERWISE SPECIFIED: ALLGEMEINTOLERANZEN n. ISO 2768 - m	APVD G. Feldmeier	16-JAN-98	NAME TUBULAR END-SLEEVE WITH PLASTIC SLEEVE, STRIP FORM, 0.5 SQmm. ADERENDHUELSE MIT KUNSTSTOFFHUELSE, BANDWARE, 0.5 SQmm.		
	PRODUCT SPEC PRODUKTSPEZ.	—	SIZE A4	CAGE CODE 00779	DRAWING NO ZEICHNUNGS-NR. C-1241000
0 PLC ± - 1 PLC ± - 2 PLC ± - 3 PLC ± - 4 PLC ± - ANGLES / WINKEL ± -	APPLICATION SPEC VERARBEITUNGSSPEZ.	—	RESTRICTED TO NUR FUER		—
	WEIGHT GEWICHT	—	SCALE MASSSTAB		5:1
CUSTOMER DRAWING / KUNDENZEICHNUNG			SHEET BLATT	1 OF VON 1	REV A3