

### Circuits from the Lab<sup>®</sup> Reference Designs

Circuits from the Lab<sup>®</sup> reference designs are engineered and tested for quick and easy system integration to help solve today's analog, mixed-signal, and RF design challenges. For more information and/or support, visit [www.analog.com/CN0357](http://www.analog.com/CN0357).

#### Devices Connected/Referenced

ADA4528-2	5.0V, Ultralow Noise, Zero Drift, RRIO, Dual Op Amp
AD5270-20	1024-Position, 1% Resistor Tolerance Error, 50-TP Memory Digital Rheostat
ADR3412	Micropower, 0.1% Accurate, 1.2V Voltage Reference
AD8500	Micropower, RRIO, Op Amp
AD7790	Low Power, 16-Bit Sigma-Delta, ADC

## Low Noise, Single-Supply, Toxic Gas Detector, Using an Electrochemical Sensor with Programmable Gain TIA for Rapid Prototyping

### EVALUATION AND DESIGN SUPPORT

#### Circuit Evaluation Boards

- [CN-0357 Circuit Evaluation Board \(EVAL-CN0357-PMDZ\)](#)
- [SDP to Pmod Interposer Board \(PMD-SDP-IB1Z\)](#)
- [System Demonstration Platform \(EVAL-SDP-CB1Z\)](#)

#### Design and Integration Files

- [Schematics, Layout Files, and Bill of Materials](#)

### CIRCUIT FUNCTION AND BENEFITS

The circuit shown in Figure 1 is a single-supply, low noise, portable gas detector, using an electrochemical sensor. The Alphasense CO-AX carbon monoxide sensor is used in this example.

Electrochemical sensors offer several advantages for instruments that detect or measure the concentration of many toxic gases. Most sensors are gas specific and have usable resolutions under one part per million (ppm) of gas concentration.

The circuit shown in Figure 1 uses the ADA4528-2, dual auto zero amplifier, which has a maximum offset voltage of 2.5  $\mu\text{V}$  at room temperature and an industry leading 5.6  $\mu\text{V}/\sqrt{\text{Hz}}$  of voltage noise density. In addition, the AD5270-20 programmable rheostat is used rather than a fixed transimpedance resistor, allowing for rapid prototyping of different gas sensor systems, without changing the bill of materials.

The ADR3412 precision, low noise, micropower reference establishes the 1.2V common-mode, pseudo ground reference voltage with 0.1% accuracy and 8 ppm/ $^{\circ}\text{C}$  drift.

For applications where measuring fractions of ppm gas concentration is important, using the ADA4528-2 and the ADR3412 makes the circuit performance suitable for interfacing with a 16-bit ADC, such as the AD7790.

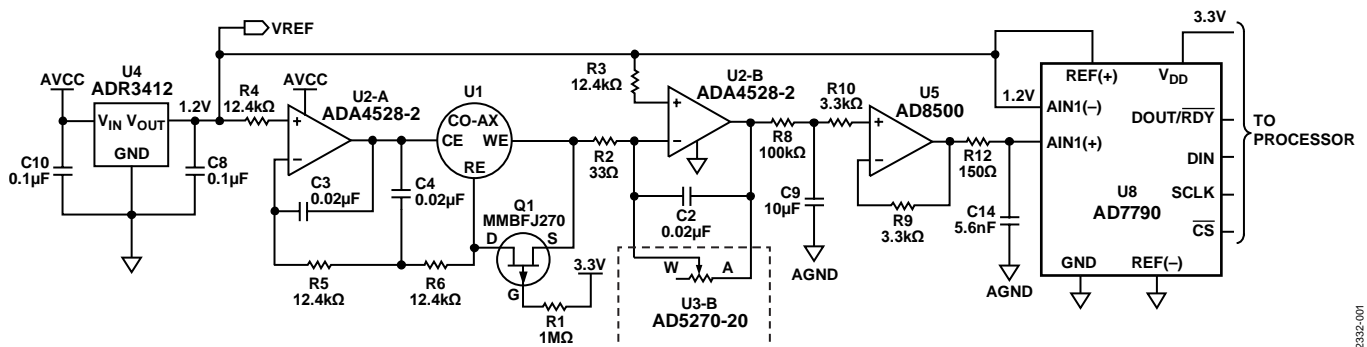

Figure 1. Low Noise Gas Detector Circuit (Simplified Schematic: all Connections and Decoupling not Shown)

#### Rev. 0

Circuits from the Lab<sup>®</sup> reference designs from Analog Devices have been designed and built by Analog Devices engineers. Standard engineering practices have been employed in the design and construction of each circuit, and their function and performance have been tested and verified in a lab environment at room temperature. However, you are solely responsible for testing the circuit and determining its suitability and applicability for your use and application. Accordingly, in no event shall Analog Devices be liable for direct, indirect, special, incidental, consequential or punitive damages due to any cause whatsoever connected to the use of any Circuits from the Lab circuits. (Continued on last page)

## CIRCUIT DESCRIPTION

Figure 2 shows a simplified schematic of an electrochemical sensor measurement circuit. Electrochemical sensors work by allowing gas to diffuse into the sensor through a membrane and by interacting with the working electrode (WE). The sensor reference electrode (RE) provides feedback to Amplifier U2-A, which maintains a constant potential with the WE terminal by varying the voltage at the counter electrode (CE). The direction of the current at the WE terminal depends on whether the reaction occurring within the sensor is oxidation or reduction. In the case of a carbon monoxide sensor, oxidation takes place; therefore, the current flows into the working electrode, which requires the counter electrode to be at a negative voltage (typically 300 mV to 400 mV) with respect to the working electrode. The op amp driving the CE terminal should have an output voltage range of approximately  $\pm 1$  V with respect to  $V_{REF}$  to provide sufficient headroom for operation with different types of sensors (Alphasense Application Note AAN-105-03, *Designing a Potentiostatic Circuit*, Alphasense, Ltd.).

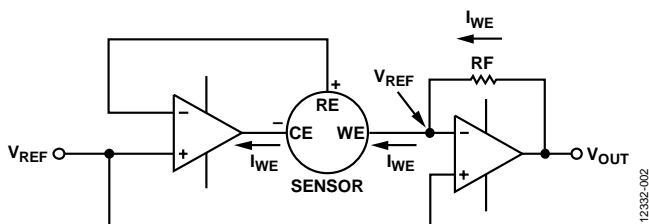

Figure 2. Simplified Electrochemical Sensor Circuit

The current into the WE terminal is less than 100 nA per ppm of gas concentration; therefore, converting this current into an output voltage requires a transimpedance amplifier with a very low input bias current. The [ADA4528-2](#) op amp has CMOS inputs with a maximum input bias current of 220 pA at room temperature, making it a very good fit for this application.

The [ADR3412](#) establishes the pseudo ground reference for the circuit, which allows for single-supply operation while consuming very little quiescent current (100  $\mu$ A maximum).

Amplifier U2-A sinks enough current from the CE terminal to maintain a 0 V potential between the WE terminal and the RE terminal on the sensor. The RE terminal is connected to the inverting input of Amplifier U2-A; therefore, no current flows in or out of it. This means that the current comes from the WE terminal and it changes linearly with gas concentration. Transimpedance Amplifier U2-B converts the sensor current into a voltage proportional to the gas concentration.

The sensor selected for this circuit is an Alphasense CO-AX carbon monoxide sensor. Table 1 shows the typical specifications associated with carbon monoxide sensors of this general type.

Warning: carbon monoxide is a toxic gas, and concentrations higher than 250 ppm can be dangerous; therefore, take extreme care when testing this circuit.

Table 1. Typical Carbon Monoxide Sensor Specifications

Parameter	Value
Sensitivity	55 nA/ppm to 100 nA/ppm (65 nA/ppm typical)
Response Time ( $t_{90}$ from 0 ppm to 400 ppm CO)	<30 seconds
Range (ppm) CO, Guaranteed Performance)	0 ppm to 2,000 ppm
Overrange Limit (Specifications Not Guaranteed)	4,000 ppm

The output voltage of the transimpedance amplifier is

$$V_O = 1.2 \text{ V} + I_{WE} \times R_F \quad (1)$$

where  $I_{WE}$  is the current into the WE terminal, and  $R_F$  is the transimpedance feedback resistor (shown as the [AD5270-20](#) U3-B rheostat in Figure 1).

The maximum response of the CO-AX sensor is 100 nA/ppm, and its maximum input range is 2000 ppm of carbon monoxide. These values result in a maximum output current of 200  $\mu$ A and a maximum output voltage determined by the transimpedance resistor, as shown in Equation 2.

$$V_O = 1.2 \text{ V} + 2000 \text{ ppm} \times 100 \frac{\text{nA}}{\text{ppm}} \times R_F$$

$$V_O = 1.2 \text{ V} + 200 \mu\text{A} \times R_F \quad (2)$$

Applying 1.2 V to  $V_{REF}$  of the [AD7790](#) allows a usable range of  $\pm 1.2$  V at the output of the transimpedance amplifier, U2-B. Selecting a 6.0 k $\Omega$  resistor for the transimpedance feedback resistor gives a maximum output voltage of 2.4 V.

Equation 3 shows the circuit output voltage as a function of ppm of carbon monoxide, using the typical response of the sensor of 65 nA/ppm.

$$V_O = 1.2 \text{ V} + 390 \frac{\mu\text{V}}{\text{ppm}} \quad (3)$$

The [AD5270-20](#) has a nominal resistance value of 20 k $\Omega$ . There are 1024 resistance positions, resulting in resistance step sizes of 19.5  $\Omega$ . The 5 ppm/ $^{\circ}$ C resistance temperature coefficient of the [AD5270-20](#) is better than that of most discrete resistors, and its 1  $\mu$ A of supply current is a very small contributor to the overall power consumption of the system.

Resistor R4 keeps the noise gain at a reasonable level. Selecting the value of this resistor is a compromise between the magnitude of the noise gain and the sensor settling time errors, when exposed to high concentrations of gas. For the example shown in Equation 4,  $R_4 = 33 \Omega$ , which results in a noise gain of 183.

$$NG = 1 + \frac{6.0 \text{ k}\Omega}{33 \Omega} = 183 \quad (4)$$

The input noise of the transimpedance amplifier appears at the output, amplified by the noise gain. For this circuit, only low frequency noise is of interest because the frequency of operation of the sensor is very low. The [ADA4528-2](#) has a 0.1 Hz to 10 Hz input voltage noise of 97 nV p-p; therefore, the noise at the output is 18  $\mu$ V p-p, as shown in Equation 5.

$$V_{OUTPUTNOISE} = 97 \text{ nV} \times NG = 18 \text{ } \mu\text{V p-p} \quad (5)$$

Because this is a very low frequency 1/f noise, the noise is very hard to filter. However, because the sensor response is also very slow, it is possible to use a very low frequency, low-pass filter (R5 and C6) with a cutoff frequency of 0.16 Hz. Even with such a low frequency filter, its effect on the sensor response time is negligible, when compared to the 30 second response time of the sensor.

The noise free code resolution of the system is determined from the peak-to-peak output noise. The maximum output of the [ADA4528-2](#) is 2.4 V, so the noise free number of counts is

$$\text{Total Noise Free Counts} = \frac{2.4 \text{ V}}{18 \text{ } \mu\text{V p-p}} = 64,865 \quad (6)$$

The noise free code resolution becomes

$$\text{Noise Free Code Resolution} = \log_2(64,865) = 15.9 \text{ bits} \quad (7)$$

To take advantage of the entire ADC range available ( $\pm 1.2$  V), the [AD8500](#) micropower, rail-to-rail input/output amplifier is chosen to drive the input of the [AD7790](#). If the entire range is not necessary, the [AD8500](#) can be removed and the internal buffer of the [AD7790](#) can be used in its place.

One important characteristic of electrochemical sensors is their very long time constant. When first powered up, it can take several minutes for the output to settle to its final value. When exposed to a midscale step in concentration of the target gas, the time required for the sensor output to reach 90% of its final value can be in the order of 25 seconds to 40 seconds. If the voltage between the RE terminal and the WE terminal has a sudden change in magnitude, it can take several minutes for the output current of the sensor to settle. This long time constant also applies when cycling power to the sensor. To avoid very long start-up times, P-channel JFET Q1 shorts the RE terminal to the WE terminal when the supply voltage drops below the gate-to-source threshold voltage ( $\sim 2.0$  V) of the JFET.

## COMMON VARIATIONS

Electrochemical sensors operate with very small amounts of current, making them well suited for portable, battery-powered instruments. If lower power is required, the [ADA4505-2](#) amplifier has a maximum input bias current of 2 pA and consumes only 10  $\mu$ A per amplifier. However, the noise of the [ADA4505-2](#) is greater than that of the [ADA4528-2](#).

The [ADR291](#) precision voltage reference consumes only 12  $\mu$ A and can be substituted for the [ADR3412](#), if lower power is required.

More information can be found in Circuit Note [CN-0234](#).

## CIRCUIT EVALUATION AND TEST

The circuit shown in Figure 1 uses the [EVAL-CN0357-PMDZ](#) circuit evaluation board, the [PMD-SDP-IB1Z](#) interposer board, and the [EVAL-SDP-CB1Z](#) system demonstration platform (SDP-B) controller board. In addition, the [EVAL-CN0357-PMDZ](#) comes in a Pmod form factor, making it possible to connect the board to any Pmod controller board, allowing for rapid prototyping.

The [CN-0357 Evaluation Software](#) communicates with the SDP board to capture data from the [EVAL-CN0357-PMDZ](#) circuit evaluation board.

### Equipment Needed

The following equipment is needed for evaluating the CN-0357 circuit:

- PC with USB port and Windows® XP, or Windows Vista (32-bit), or Windows 7 (32-bit)
- [EVAL-CN0357-PMDZ](#) evaluation board
- [PMD-SDP-IB1Z](#) interposer Board
- [EVAL-SDP-CB1Z](#) controller board
- [CN-0357 Evaluation Software](#)
- Calibration gas (less than 250 ppm)
- [EVAL-CFTL-6V-PWRZ](#) or equivalent 6 VDC power supply

### Getting Started

Load the evaluation software by placing the [CN-0357 Evaluation Software](#) CD into the CD drive of the PC. Using **My Computer**, locate the drive that contains the evaluation software CD and run the **setup.exe**. Follow the on screen prompts for installing and using the evaluation software.

### Functional Block Diagram

A functional block diagram of the test setup is shown in Figure 3. There is a complete schematic of the evaluation board contained in the [CN-0357 Design Support Package](#), including printouts of the gerber files, as well as a bill of materials.

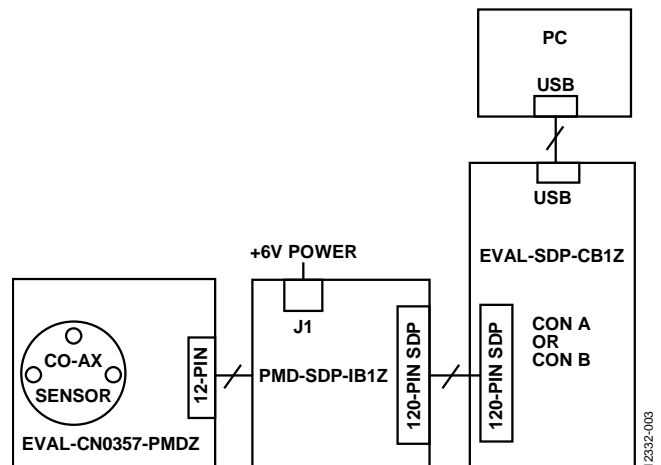

Figure 3. Test Setup Functional Block Diagram

### Setup

Connect the electrochemical sensor to the socket on the [EVAL-CN0357-PMDZ](#) circuit evaluation board.

Connect the [EVAL-CN0357-PMDZ](#) to the interposer board and ensure that the jumper on the interposer board selects +3.3 V as the configuration. Next, connect the SDP-B board to the interposer board and apply power to the interposer board via the DC barrel jack.

Connect the USB cable supplied with the SDP-B board to the USB port on the PC and to the SDP-B board.

The software can communicate with the SDP board if the **Analog Devices System Development Platform** driver appears in the **Device Manager**. When USB communications are established, the SDP board can now send, receive, and capture serial data from the [EVAL-CN0357-PMDZ](#) circuit evaluation board.

### Test

Navigate to the installation location of the [CN-0357 Evaluation Software](#) and open the CN0357.exe file. (The file should be located in a folder named Analog Devices in the start menu of the operating system.)

When the application opens, the software automatically connects to the SDP-B board. If multiple SDP-B controller boards are connected, the selected board will have a light emitting diode (LED) blinking.

The [CN-0357 Evaluation Software User Guide](#) contains information and details regarding how to use the evaluation software for data capture.

The input signal for this board is gas concentration; therefore, a calibration gas source is required. When testing with carbon monoxide, consider that 250 ppm is the maximum short term exposure limit.

The software is designed to be used with any electrochemical sensor, so it is important to input the correct specifications for the chosen sensor.

The maximum sensor sensitivity and sensor range are needed to calculate and set the resistance of the [AD5270-20](#) digital rheostat. This value is a signed value. Positive values are used to describe sensors that sink current, whereas negative values are used to describe sensors that source current.

The typical sensor sensitivity is used to calculate the system conversion coefficient of ppm/mV.

Pressing the Run button begins acquisition of concentration data at 1 second intervals.

Figure 4 shows the circuit response after rapidly removing the sensor from the 175 ppm CO atmosphere and is a better representation of circuit performance.

A photo of the [EVAL-CN0357-PMDZ](#) board is shown in Figure 5.

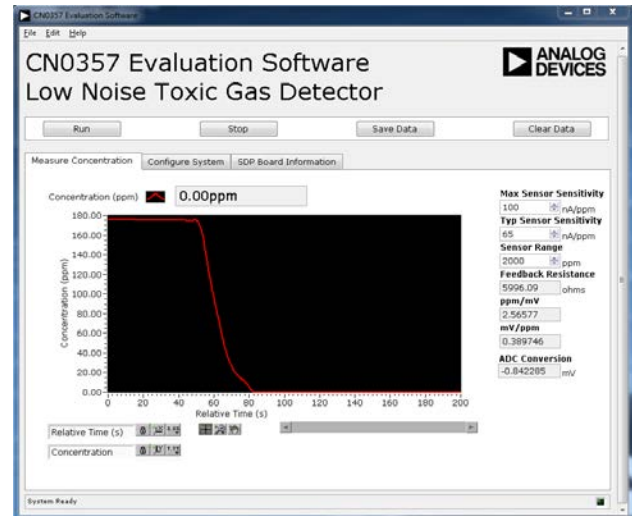

Figure 4. Response to a 175 ppm to 0 ppm Step of Carbon Monoxide



Figure 5. EVAL-CN0357-PMDZ Evaluation Board

**LEARN MORE**

CN-0357 Design Support Package:

<http://www.analog.com/CN0357-DesignSupport>

AN-1114, *Lowest Noise Zero-Drift Amplifier Has 5.6 nV/√Hz Voltage Noise Density*, Analog Devices.

MS-2066 Article, *Low Noise Signal Conditioning for Sensor-Based Circuits*, Analog Devices.

MT-035 Tutorial, *Op Amp Inputs, Outputs, Single-Supply, and Rail-to-Rail Issues*, Analog Devices.

CN-0234 Circuit Note, *Single Supply, Micropower Toxic Gas Detector Using an Electrochemical Sensor*, Analog Devices.

Alphasense Application Note AAN-105-03, *Designing a Potentiostatic Circuit*, Alphasense Limited.

**Data Sheets and Evaluation Boards**

CN-0357 Circuit Evaluation Board (EVAL-CN0357-PMDZ)

System Demonstration Platform (EVAL-SDP-CB1Z)

ADA4528-2 Data Sheet

AD5270-20 Data Sheet

ADR3412 Data Sheet

AD8500 Data Sheet

AD7790 Data Sheet

**REVISION HISTORY**

7/14—Revision 0: Initial Version

(Continued from first page) Circuits from the Lab reference designs are intended only for use with Analog Devices products and are the intellectual property of Analog Devices or its licensors. While you may use the Circuits from the Lab reference designs in the design of your product, no other license is granted by implication or otherwise under any patents or other intellectual property by application or use of the Circuits from the Lab reference designs. Information furnished by Analog Devices is believed to be accurate and reliable. However, Circuits from the Lab reference designs are supplied "as is" and without warranties of any kind, express, implied, or statutory including, but not limited to, any implied warranty of merchantability, noninfringement or fitness for a particular purpose and no responsibility is assumed by Analog Devices for their use, nor for any infringements of patents or other rights of third parties that may result from their use. Analog Devices reserves the right to change any Circuits from the Lab reference designs at any time without notice but is under no obligation to do so.

©2014 Analog Devices, Inc. All rights reserved. Trademarks and registered trademarks are the property of their respective owners.  
CN12332-0-7/14(0)

