

REVISIONS				
P	LTR	DESCRIPTION	DATE	APPV
C	REV PER ECO	17-007041	5-16-17	CT EO

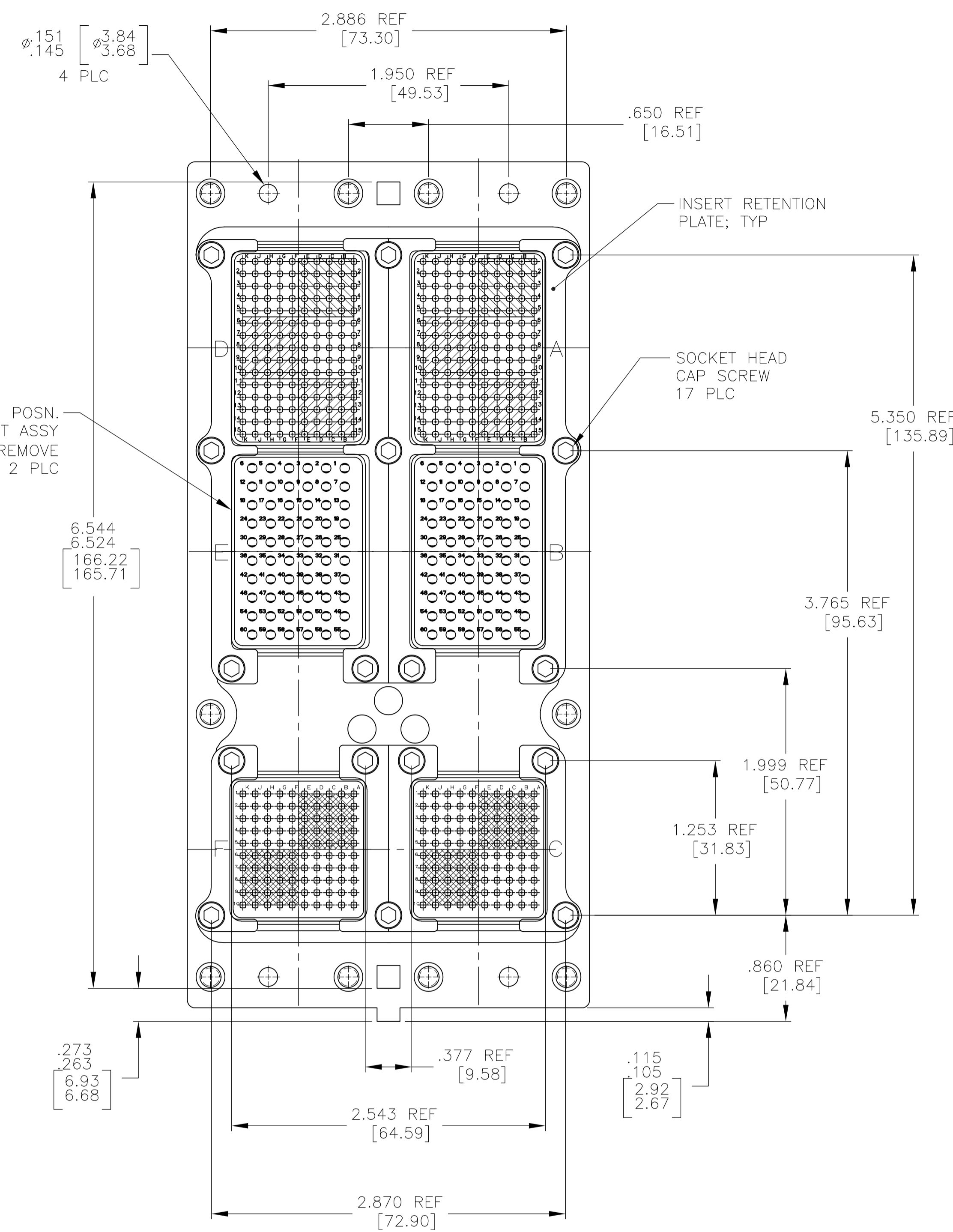
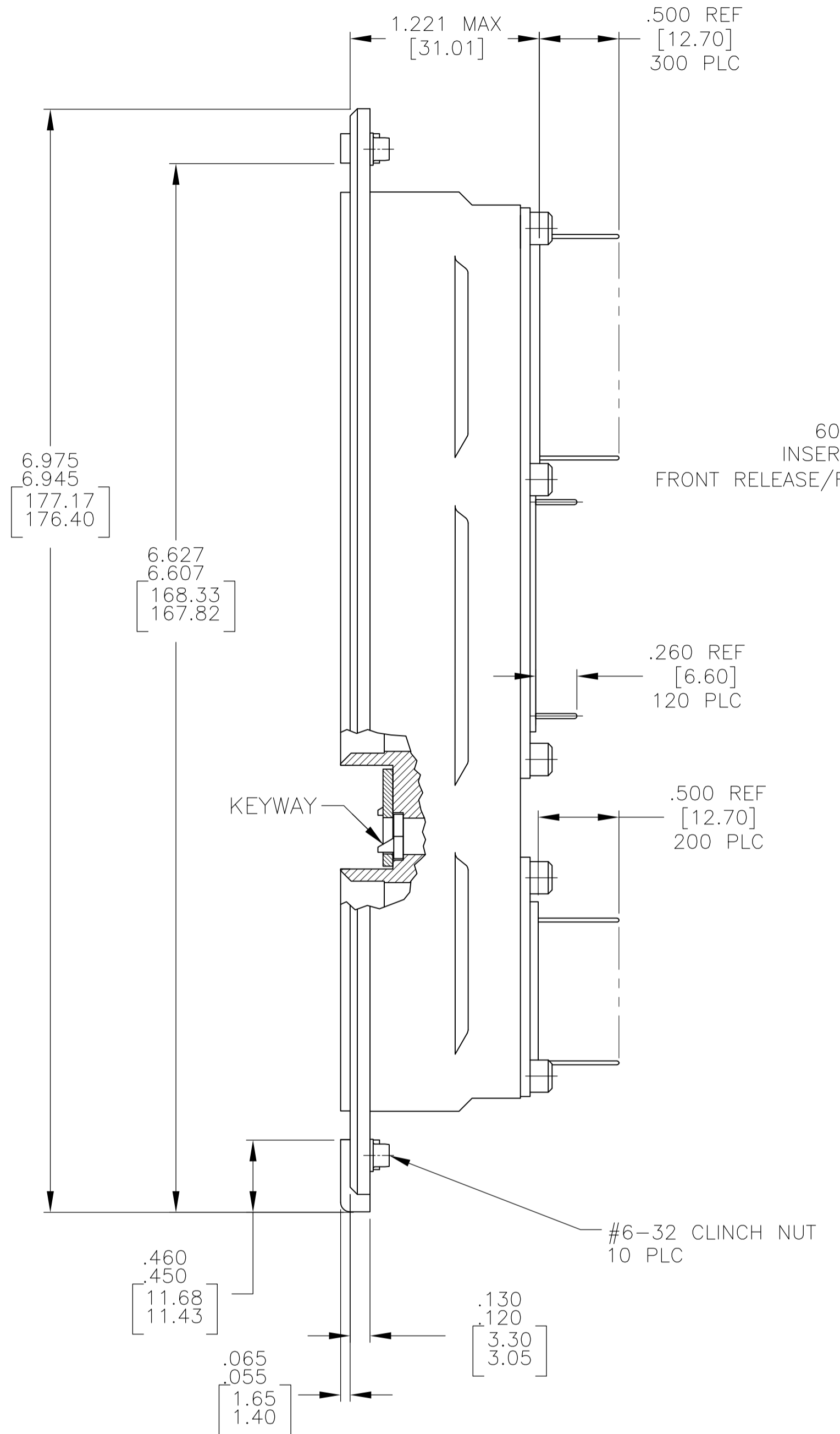
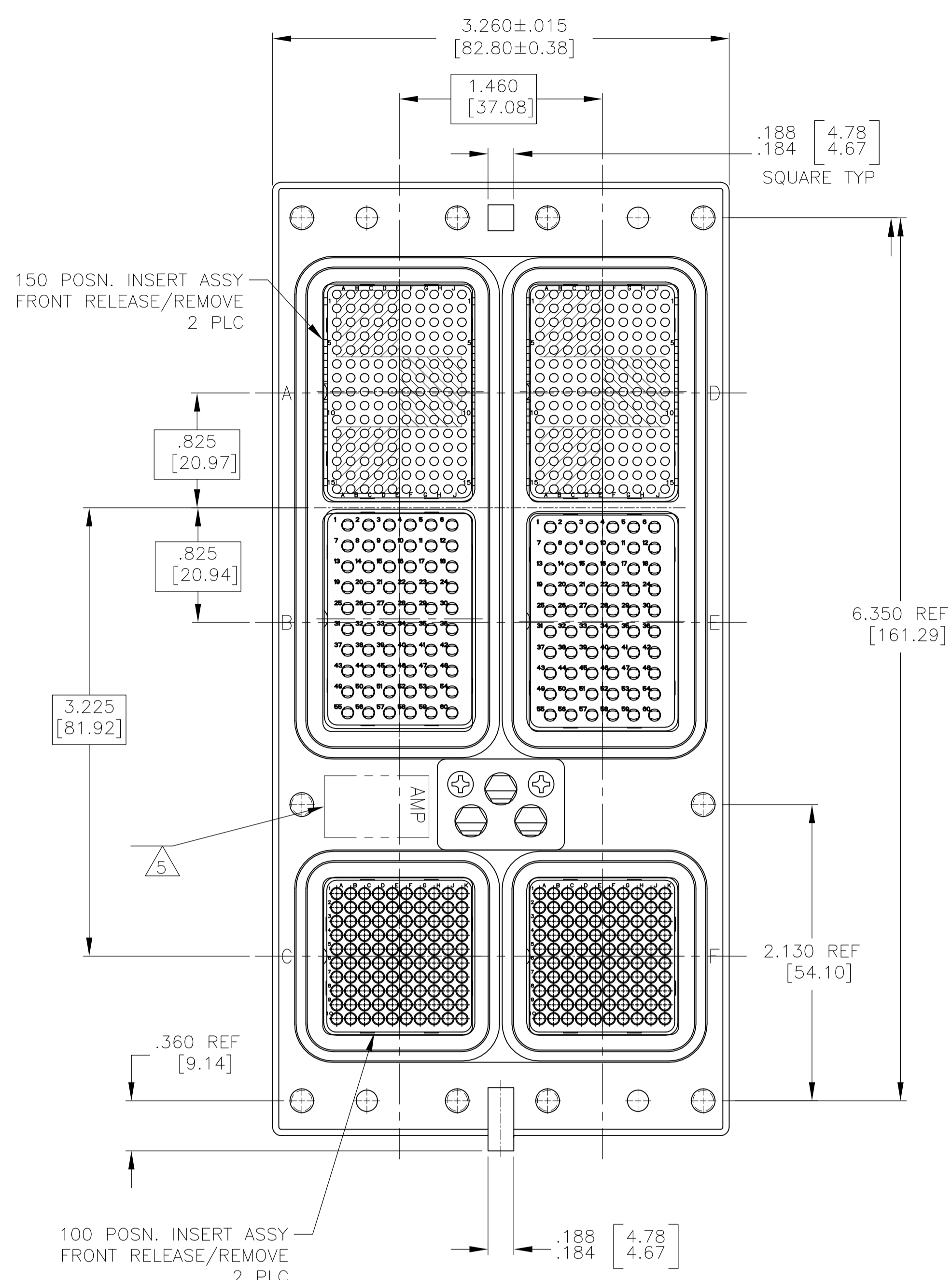

COMPONENT	MATERIAL	FINISH
SHELL	DIE CAST ALUMINUM PER ASTM-B-85 OR ASTM B211 6061-T6 OR ASTM B209 2024-T4	ELECTROLESS NICKEL PER MIL-C-26074
RETENTION PLATES	ALUMINUM ALLOY PER ASTM-B-209	ELECTROLESS NICKEL PER MIL-C-26074
RETENTION PLATE SCREWS	PER NAS1352-04-4P	PER NAS1352-04-4P
POLARIZING KEYS	ZINC ALLOY PER ASTM-B-86	-
POLARIZING KEY RETAINING PLATE	ALUMINUM ALLOY PER ASTM-B-209	BLUE ANODIZED PER MIL-A-8625
ALL INSERTS	THERMOSET	-

OBSOLETE	"06"	SAME AS -1	1996964-6	
OBSOLETE	"05"	SAME AS -1	1996964-5	
OBSOLETE	"04"	SAME AS -1	1996964-4	
OBSOLETE	"03"	SAME AS -1	1996964-3	
	"00"	NO CONTACT INCLUDED	1996964-2	
	"00"	MODULE A 211431-8 (SZ 22 POSTED SOCKET CONTACT; QTY=150) MODULE B 1-448138-2 (SZ 20 POSTED SOCKET CONTACT; QTY=60) MODULE C 211431-8 (SZ 22 POSTED SOCKET CONTACT; QTY=100) MODULE D 211431-8 (SZ 22 POSTED SOCKET CONTACT; QTY=150) MODULE E 1-448138-2 (SZ 20 POSTED SOCKET CONTACT; QTY=60) MODULE F 211431-8 (SZ 22 POSTED SOCKET CONTACT; QTY=100)		1996964-1
KEYING POSITION		CONTACTS INCLUDED AND INSTALLED	PART NUMBER	

- CONNECTOR DIMENSIONS ARE PER ARINC 600 SPECIFICATION
- DUST COVER (NOT SHOWN) INSTALLED FOR SHIPPING.
- CONTACTS NOT SHOWN IN FRONT & REAR VIEWS FOR CLARTY.
- KEYING SHOWN IN POSITION FOR REFERENCE ONLY. SEE TABLE FOR KEYING POSITION. FOR POSITION "00" KEYING SHIPPED UNASSEMBLED.
- TE LOGO APPEARS IN THIS APPROXIMATE LOCATION ON MACHINED FROM BILLET SHELLS.
- ASSEMBLY SHOWN WITH DIE CAST SHELL. ASSEMBLIES WITH MACHINED SHELLS MAY VARY SLIGHTLY IN APPEARANCE.

THIS DRAWING IS A CONTROLLED DOCUMENT.

DIMENSIONS: INCHES	TOLERANCES UNLESS OTHERWISE SPECIFIED:	DIN C.C.THOMAS 10-22-08	APPROVED K.THACKSTON 10-22-08	NAME RCPT ASSY, SIZE 3, ARINC 600 (150/60/100/150/60/100)
0 PLC ± .0005	1 PLC ± .0005	2 PLC ± .0005	3 PLC ± .0005	4 PLC ± .0005
ANGLES ± .0005	FINISH SEE TABLE	WEIGHT 0.000000	SIZE A1	CAGE CODE 00779
MATERIAL SEE TABLE	FINISH SEE TABLE	DRAWING NO. 1996964	SCALE 3:2	SHEET 1 OF 1

CUSTOMER DRAWING