

THIS DOCUMENT IS THE PROPERTY OF
KEYSTONE ELECTRONICS CORP. AND
SHALL NOT BE REPRODUCED, DISTRIBUTED
OR USED AS A BASIS FOR MANUFACTURE
WITHOUT PRIOR WRITTEN PERMISSION
FROM KEYSTONE ELECTRONICS CORP.

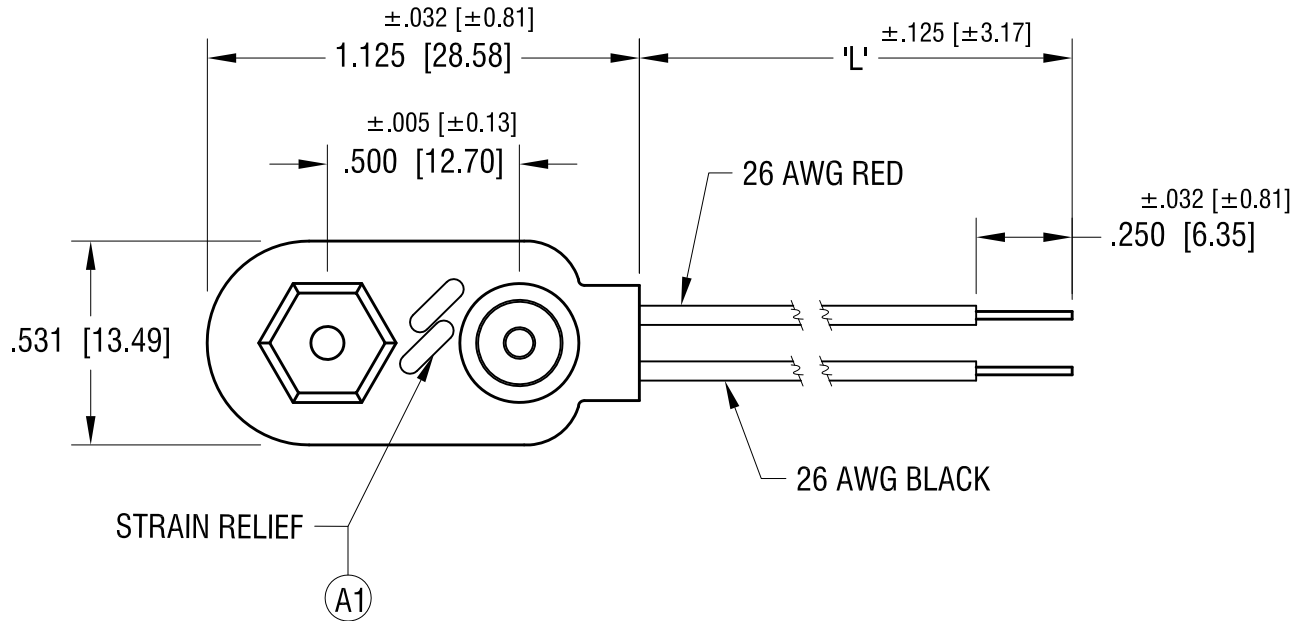

NOTE:

- MAT'L - WIRE: 26 AWG, 1007 UL/CSA APPROVED
CONTACTS: BRASS, NICKEL PLATE
.012 [0.30] MINIMUM THICKNESS PVC &
.032 [0.81] THICK FIBER INSULATION.
RED WIRE CONNECTED TO FEMALE CONTACT;
BLACK WIRE CONNECTED TO MALE CONTACT.

PART NO.	'L' DIM.
232	4.000 [101.60]
233	6.000 [152.40]
234	8.000 [203.20]

6.20.17	ADD STRAIN RELIEF (A1) CHANGE AS PER ECN 17-043	A
DATE	DESCRIPTION	REV.

KEYSTONE ELECTRONICS CORP.			
www.keyelco.com • ASTORIA, N.Y. 11105-2017 • Tel (718) 956-8900			
PART NAME ECONOMY '9' VOLT BATTERY STRAP			
MATERIAL AS NOTED			
FINISH AS NOTED		DRN BY BOONE	DATE 4.25.95
		APP'D LN	SCALE 2X
TOLERANCES DECIMAL ANGULAR UNLESS OTHERWISE SPECIFIED	INCH [MM] ± .015 [± 0.38] ± 1°	CODE C	DWG NO. 232-234