

**K-no.: 26019**
**25 A Current Sensor for 5V- Supply Voltage**

 For electronic current measurement:  
 DC, AC, pulsed, mixed ..., with a galvanic  
 isolation between primary circuit  
 (high power) and secondary circuit  
 (electronic circuit)

**Date: 05.02.2014**
**Customer: Standard type**
**Customers Part no.:**
**Page 1 of 2**
**Description**

- Closed loop (compensation)
- Current Sensor with magnetic field probe
- Printed circuit board mounting
- Casing and materials UL-listed

**Characteristics**

- Excellent accuracy
- Very low offset current
- Very low temperature dependency and offset current drift
- Very low hysteresis of offset current
- Short response time
- Wide frequency bandwidth
- Compact design
- Reduced offset ripple

**Applications**

Mainly used for stationary operation in industrial applications:

- AC variable speed drives and servo motor drives
- Static converters for DC motor drives
- Battery supplied applications
- Switched Mode Power Supplies (SMPS)
- Power Supplies for welding applications
- Uninterruptible Power Supplies (UPS)

**Electrical data – Ratings**

$I_{PN}$	Primary nominal r.m.s. current	25	A
$V_{out}$	Output voltage @ $I_P$	$V_{Ref} \pm (0.625 \cdot I_P / I_{PN})$	V
$V_{out}$	Output voltage @ $I_P=0, T_A=25^\circ C$	$V_{Ref} \pm 0.00135$	V
$V_{Ref}$	External Reference voltage range	0...4	V
	Internal Reference voltage	$2.5 \pm 0.005$	V
$K_N$	Turns ratio	1...4 : 2000	

**Accuracy – Dynamic performance data**

		min.	typ.	max.	Unit
$I_{P,max}$	Max. measuring range	±85			
X	Accuracy @ $I_{PN}, T_A=25^\circ C$			0.7	%
$\epsilon_L$	Linearity			0.1	%
$V_{out} - V_{Ref}$	Offset voltage @ $I_P=0, T_A=25^\circ C$			±1.35	mV
$\Delta V_o / V_{Ref} / \Delta T$	Temperature drift of $V_{out}$ @ $I_P=0, V_{Ref}=2,5V, T_A=-40...85^\circ C$	1.4	10		ppm/°C
$t_r$	Response time @ 90% von $I_{PN}$		300		ns
$\Delta t (I_{P,max})$	Delay time at $di/dt = 100 A/\mu s$		200		ns
f	Frequency bandwidth	DC...200			kHz

**General data**

		min.	typ.	max.	Unit
$T_A$	Ambient operating temperature	-40		+85	°C
$T_S$	Ambient storage temperature	-40		+105	°C
m	Mass		12		g
$V_C$	Supply voltage	4.75	5	5.25	V
$I_C$	Current consumption		15		mA

 Constructed and manufactured and tested in accordance with EN 61800-5-1 (Pin 1 – 4 to Pin 5 – 12)  
 Reinforced insulation, Insulation material group 1, Pollution degree 2

$S_{clear}$	Clearance (component without solder pad)	9.6			mm
$S_{creep}$	Creepage (component without solder pad)	10.6			mm
$V_{sys}$	System voltage overvoltage category 3	RMS		600	V
$V_{work}$	Working voltage	RMS		1060	V
$U_{PD}$	Rated discharge voltage	peak value		1320	V

 Note: According UL 508: Max. potential difference = 600 V<sub>A</sub>

Date	Name	Issue	Amendment
05.02.14	Ga.	83	Marking changed acc to UL-specification. 4646X761-82 → 4646-X761-83. CN-922
24.05.13	Ga.	82	Schematic diagram: Iout changed to Vout on Pin2. Mechanical outline: size 1.84 added. Lapidary change.

Hrsg.: KB-E editor	Bearb: Le designer	KB-PM: Ga. check	freig.: HS released
-----------------------	-----------------------	---------------------	------------------------

K-no.: 26019

## 25 A Current Sensor for 5V- Supply Voltage

For electronic current measurement:  
DC, AC, pulsed, mixed ..., with a galvanic  
isolation between primary circuit  
(high power) and secondary circuit  
(electronic circuit)

Date: 05.02.2014

Customer: Standard type

Customers Part no.:

Page 2 of 2

### Mechanical outline (mm):

General tolerances DIN ISO 2768-c

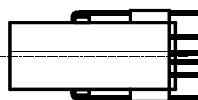
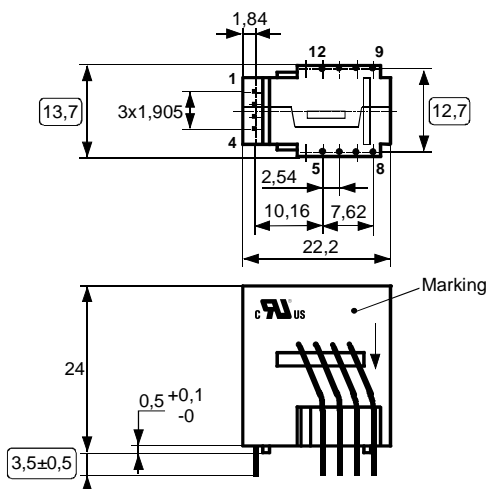

Connections:

1...4: 0,46\*0,46 mm  
5..12: Ø 1 mm

Marking:

**VAC** UL-sign  
4646-X761-83  
F DC

○ test dimension

Tolerances grid distance ±0,25mm

DC= Date Code  
F = Factory

Explanation:

DC = Date Code [YWW]

### Schematic diagram

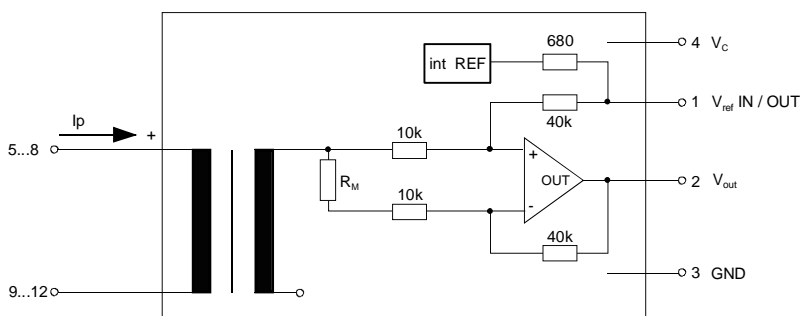

### Possibilities of wiring (@ T<sub>A</sub> = 85°C)

primary windings	primary current RMS	primary current maximal	output voltage RMS	turns ratio	primary resistance	wiring
N <sub>P</sub>	I <sub>P</sub> [A]	I <sub>P,max</sub> [A]	V <sub>out</sub> (I <sub>P</sub> ) [V]	K <sub>N</sub>	R <sub>P</sub> [mΩ]	
1	25	±85	2.5±0.625	1:2000	0.25	
2	12	±42	2.5±0.600	2:2000	1.0	
4	6	±21	2.5±0.600	4:2000	4	

Operating temperature of the current sensor and the primary conductor must not exceed 105°C.

Additional information is obtainable on request.

This specification is no declaration of warranty acc. BGB §443 dar.

Hrsg.: KB-E  
editor

Bearb: Le  
designer

KB-PM: Ga.  
check

freig.: HS  
released

**K-No.:** 26019

**25 A Current Sensor for 5V-Supply Voltage**

 For the electronic measurement of currents:  
 DC, AC, pulsed, mixed ..., with a galvanic  
 isolation between the primary circuit  
 (high power) and the secondary circuit

**Date:** 05.02.2014

**Customer:**
**Customers Part No.:**
**Page** 1 **of** 2

**Electrical Data**

		min.	typ.	max.	Unit
$V_{Ctot}$	Maximum supply voltage (without function)			7	V
$I_C$	Supply Current with primary current		15mA + $I_p \cdot K_N + V_{out}/R_L$		mA
$I_{out,SC}$	Short circuit output current		$\pm 20$		mA
$R_P$	Resistance / primary winding @ $T_A=25^\circ C$		1		m $\Omega$
$R_S$	Secondary coil resistance @ $T_A=85^\circ C$			67	$\Omega$
$R_{i,Ref}$	Internal resistance of Reference input		670		$\Omega$
$R_{is}(V_{out})$	Output resistance of $V_{out}$			1	$\Omega$
$R_L$	External recommended resistance of $V_{out}$	1			k $\Omega$
$C_L$	External recommended capacitance of $V_{out}$			500	pF
$\Delta X_{Ti}/\Delta T$	Temperature drift of X @ $T_A = -40 \dots +85^\circ C$			40	ppm/K
$\Delta V_0 = \Delta(V_{out} - V_{Ref})$	Sum of any offset drift including:		2	6	mV
$V_{0t}$	Longtermdrift of $V_0$		1		mV
$V_{0T}$	Temperature drift von $V_0$ @ $T_A = -40 \dots +85^\circ C$		1		mV
$V_{0H}$	Hysteresis of $V_{out}$ @ $I_p=0$ (after an overload of $10 \times I_{PN}$ )			2	mV
$V_{0H}$	Hysteresis of $V_{out}$ @ $I_p=0$ (after an overload of 66 A)			0.5	mV
$\Delta V_0/\Delta V_C$	Supply voltage rejection ratio			1	mV/V
$V_{oss}$	Offsetripple (with 1 MHz- filter first order)			30	mV
$V_{oss}$	Offsetripple (with 100 kHz- filter first order)		3	6	mV
$V_{oss}$	Offsetripple (with 20 kHz- filter first order)		0.8	1.5	mV
$C_k$	Maximum possible coupling capacity (primary – secondary) Mechanical stress according to M3209/3 Settings: 10 – 2000 Hz, 1 min/Octave, 2 hours		5	10 30g	pF

**Inspection** (Measurement after temperature balance of the samples at room temperature; SC = significant characteristic)

$V_{out}(I_p=I_{PN})$	(V)	M3011/6:	Output voltage vs. external reference ( $I_p=25A$ , 40-80Hz)	$625 \pm 0,7\%$	mV (SC)
$V_{out} - V_{Ref}(I_p=0)$	(V)	M3226:	Offset voltage	$\pm 1.35$	mV
$V_d$	(V)	M3014:	Test voltage, rms, 1 s pin 1 – 4 vs. pin 5 – 12	1.8	kV
$V_e$	(AQL 1/S4)		Partial discharge voltage acc.M3024 (RMS) with $V_{vor}$ (RMS)	1400 1750	V V

**Type Testing** (Pin 1 - 4 to Pin 5 - 12)

$V_W$			HV transient test according to M3064 (1,2 $\mu s$ / 50 $\mu s$ -wave form)	8	kV	
$V_d$			Testing voltage to M3014	(5 s)	3.6	kV
$V_e$			Partial discharge voltage acc.M3024 (RMS) with $V_{vor}$ (RMS)	1400 1750	V V	

**Applicable documents**

Current direction: A positive output current appears at point  $I_s$ , by primary current in direction of the arrow.  
 Housing and bobbin material UL-listed: Flammability class 94V-0.  
 Enclosures according to IEC529: IP50.

Further standards UL 508 ; file E317483, category NMTR2 / NMTR8

Datum	Name	Index	Amendment
05.02.14	Ga.	83	Date updated.
24.05.13	Ga.	82	Vctot changed from 6V to 7V. lapidary change.

Hrsg.: KB-E editor	Bearb.: Le. designer		KB-PM: Kre. check		freig.: HS released
-----------------------	-------------------------	--	----------------------	--	------------------------

Weitergabe sowie Vervielfältigung dieser Unterlage, Verwertung und Mitteilung ihres Inhalts nicht gestattet, soweit nicht ausdrücklich zugestanden. Zuwiderhandlungen verpflichten zu Schadenersatz. Alle Rechte für den Fall der Patenterteilung oder GM-Eintragung vorbehalten

Copying of this document, disclosing it to third parties or using the contents there for any purposes without express written authorization by use illegally forbidden.  
 Any offenders are liable to pay all relevant damages.

**K-No.:** 26019

**25 A Current Sensor for 5V-Supply Voltage**

 For the electronic measurement of currents:  
 DC, AC, pulsed, mixed ..., with a galvanic  
 isolation between the primary circuit  
 (high power) and the secondary circuit

**Date:** 05.02.2014

**Customer:**
**Customers Part No.:**
**Page** 2 **of** 2

**Explanation of several of the terms used in the tablets (in alphabetical order)**

**t:** Response time (describe the dynamic performance for the specified measurement range), measured as delay time at  $I_P = 0,9 \cdot I_{PN}$  between a rectangular current and the output voltage  $V_{out}(I_P)$

**$\Delta t (I_{Pmax})$ :** Delay time (describe the dynamic performance for the rapid current pulse rate e.g short circuit current) measured between  $I_{Pmax}$  and the output voltage  $V_{out}(I_{Pmax})$  with a primary current rise of  $di_P/dt \geq 100 \text{ A}/\mu\text{s}$ .

**$V_0$ :** Offset voltage between  $V_{out}$  and the rated reference voltage of  $V_{ref} = 2,5V$ .  
 $V_0 = V_{out}(0) - 2,5V$

**$U_{PD}$**  Rated discharge voltage (recurring peak voltage separated by the insulation) proved with a sinusoidal voltage  $V_e$   
 $U_{PD} = \sqrt{2} \cdot V_e / 1,5$

**$V_{vor}$**  Defined voltage is the RMS value of a sinusoidal voltage with peak value of  $1,875 \cdot U_{PD}$  required for partial discharge test in IEC 61800-5-1  
 $V_{vor} = 1,875 \cdot U_{PD} / \sqrt{2}$

**$V_{sys}$**  System voltage RMS value of rated voltage according to IEC 61800-5-1

**$V_{work}$**  Working voltage voltage according to IEC 61800-5-1 which occurs by design in a circuit or across insulation

**$V_{0H}$ :** Zero variation of  $V_0$  after overloading with a DC of tenfold the rated value

**$V_{0t}$ :** Long term drift of  $V_0$  after 100 temperature cycles in the range -40 bis 85 °C.

**X:** Permissible measurement error in the final inspection at RT, defined by

$$X = 100 \cdot \left| \frac{V_{out}(I_{PN}) - V_{out}(0)}{0,625V} - 1 \right| \%$$

**$X_{ges}(I_{PN})$ :** Permissible measurement error including any drifts over the temperature range by the current measurement  $I_{PN}$

$$X_{ges} = 100 \cdot \left| \frac{V_{out}(I_{PN}) - 2,5V}{0,625V} - 1 \right| \% \quad \text{or} \quad X_{ges} = 100 \cdot \left| \frac{V_{out}(I_{PN}) - V_{ref}}{0,625V} - 1 \right| \%$$

**$\epsilon_L$ :** Linearity fault defined by  $\epsilon_L = 100 \cdot \left| \frac{I_P}{I_{PN}} - \frac{V_{out}(I_P) - V_{out}(0)}{V_{out}(I_{PN}) - V_{out}(0)} \right| \%$

This "Additional information" is no declaration of warranty according BGB §443.

**Hrsg.:** KB-E  
 editor

**Bearb.:** Le.  
 designer

**KB-PM:** Kre.  
 check

**freig.:** HS  
 released