

7
6
5
4
3
2
1

DN000080000R01_CUST

RELEVANT SPEC.	SHT	1	OF	1
NA	EX No.	10688-01		
PROJ MODEL FILE	DN000080000R01			

IF IN DOUBT - ASK
ALL DIMENSIONS ARE IN mm

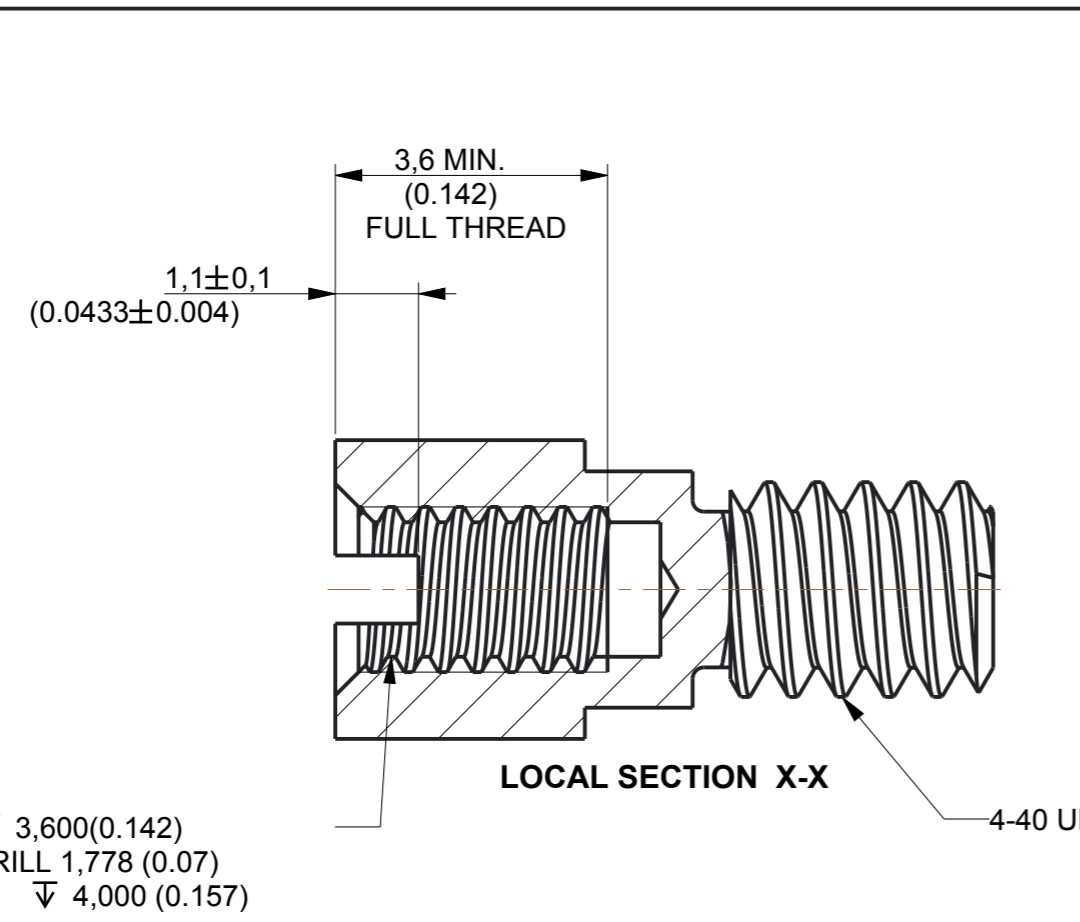

- NOTES:
- DIMENSIONS ARE FOR REFERENCE ONLY. IMPERIAL DIMENSIONS SHOWN IN PERENTHESIS.
 - CUSTOMER DRAWING ONLY. NOT USED FOR CINCH MANUFACTURE.
- MATERIAL SPECIFICATIONS:
- JACKPOST: >303SS< PASSIVATE DIP PER SAE-AMS-QQ-P-35.
- GENERAL SPECIFICATIONS:
- FOR ALL OTHER DETAILS AND DIMENSIONS SEE CINCH DURA-CON HERMETIC CATALOGUE.

2-56 UNC-2B TAP ∇ 3,600(0.142)
#50 DRILL 1,778 (0.07)
 ∇ 4,000 (0.157)

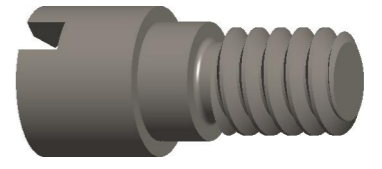
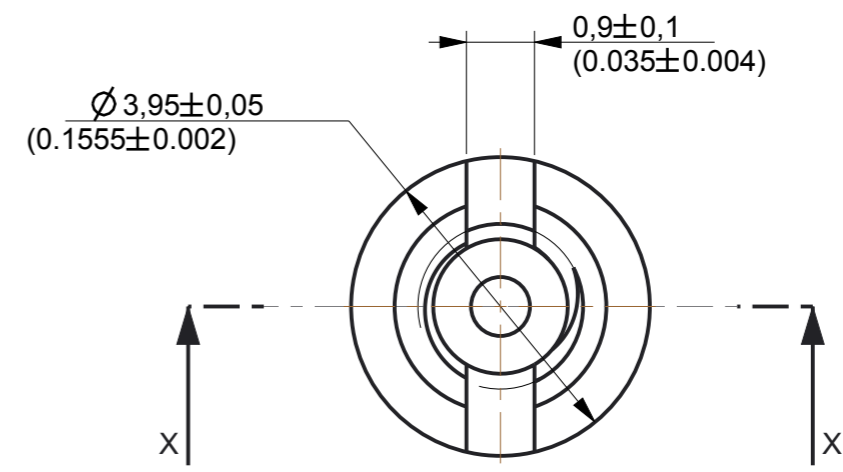
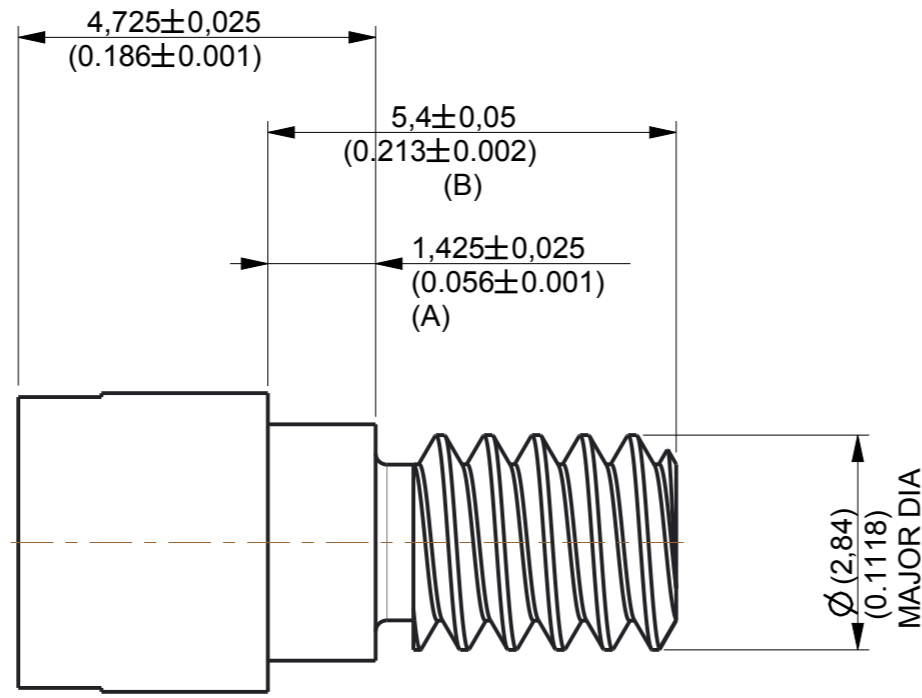

SCALE 5,000

PART NUMBER	SALES_CODE	A	A_IMPERIAL	B	B_IMPERIAL	DESCRIPTION2
DN00008080PAR01	DN00008 08	0,625	0,025	4,600	0,181	2-56UNC REAR PNL J/POST (0.8)
DN00008120PAR01	DN00008 12	1,025	0,040	5,000	0,197	2-56UNC REAR PNL J/POST (1.2)
DN00008160PAR01	DN00008 16	1,425	0,056	5,400	0,213	2-56UNC REAR PNL J/POST (1.6)
DN00008240PAR01	DN00008 24	2,225	0,088	6,200	0,244	2-56UNC REAR PNL J/POST (2.4)
DN00008200PAR01	DN00008 20	1,825	0,072	5,800	0,228	2-56UNC REAR PNL J/POST (2.0)

THIS DRAWING IS COPYRIGHT AND IS ISSUED ON CONDITION IT IS NOT COPIED, REPRODUCED OR DISCLOSED TO A THIRD PARTY WITHOUT THE CONSENT IN WRITING OF Cinch CONNECTIVITY SOLUTIONS LTD. ATTENTION IS DRAWN TO THE FACT THE ARTICLE DISCLOSED MAY BE COVERED BY BRITISH OR FOREIGN PATENTS, GRANTED OR PENDING OR REGISTERED DESIGN.

HARDWARE		REAR PANEL MOUNTING JACKPOST	
APPD	DATE	NPNR ECN	ISSUE
	03-Oct-08	PRELIM.	A
	02-Jan-09	IMP DIMS	B
	02-Mar-17		C
GEN. TOLERANCES		TITLE	
2 DEC. PL.	±0.1	RAW MATL.	
1 DEC. PL.	±0.2	FINISHED HARDNESS	
0 DEC. PL.	±0.5	FINISH TREATMENT	
ANGULAR	±1	COLOUR	
TOOL R. MAX.	0.18		

DRN	M.BARRACLOUGH	DATE	30-Jan-09	SCALE	10,000	CHD	NOT
				MATERIAL SPECIFICATION	APPD	NOT	NOT

CODE	DESCRIPTION	ITEM	FINISH/MATL	QTY
	2-56UNC REAR PANEL JACKPOST	2		1
	2-56UNC REAR PANEL JACKPOST	1		1

Cinch CONNECTIVITY SOLUTIONS Ltd. Worksop, England.

ISSUE GROUPS
B