

7  
6  
5  
4  
3  
2  
1

DN000080000R01\_CUST

RELEVANT SPEC.	SHT	1	OF	1
NA	EX No.	10688-01		
PROJ MODEL FILE	DN000080000R01			

**IF IN DOUBT - ASK**  
ALL DIMENSIONS ARE IN mm

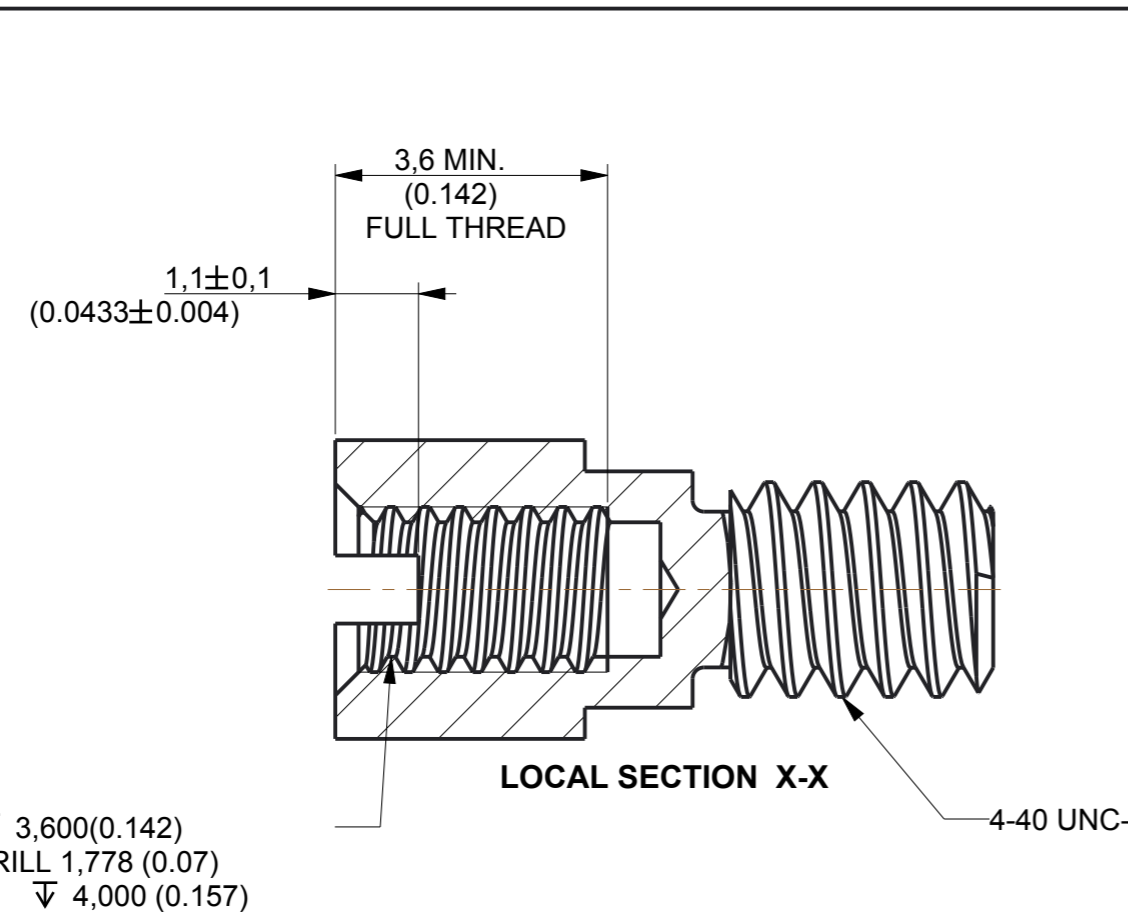

NOTES:

- DIMENSIONS ARE FOR REFERENCE ONLY. IMPERIAL DIMENSIONS SHOWN IN PERENTHESIS.
- CUSTOMER DRAWING ONLY. NOT USED FOR CINCH MANUFACTURE.

MATERIAL SPECIFICATIONS:

- JACKPOST: >303SS< PASSIVATE DIP PER SAE-AMS-QQ-P-35.

GENERAL SPECIFICATIONS:

- FOR ALL OTHER DETAILS AND DIMENSIONS SEE CINCH DURA-CON HERMETIC CATALOGUE.

2-56 UNC-2B TAP  $\nabla$  3,600(0.142)  
#50 DRILL 1,778 (0.07)  
 $\nabla$  4,000 (0.157)

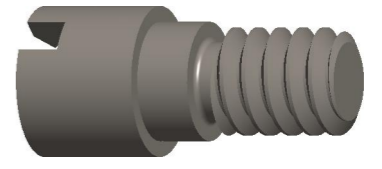
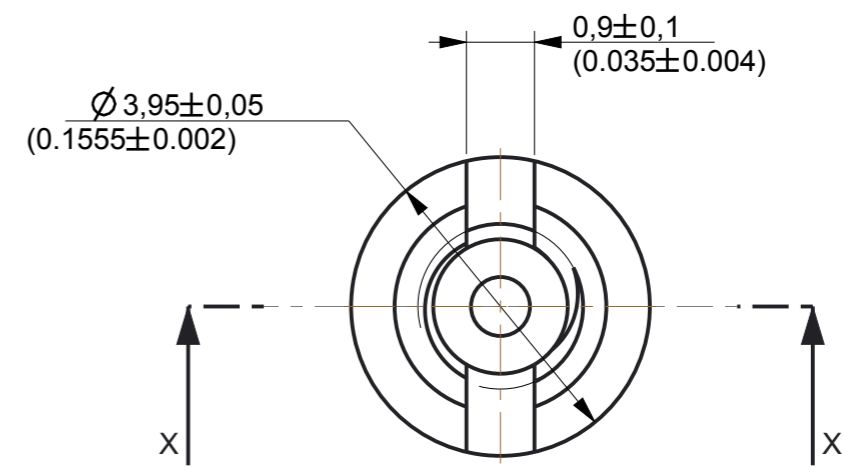
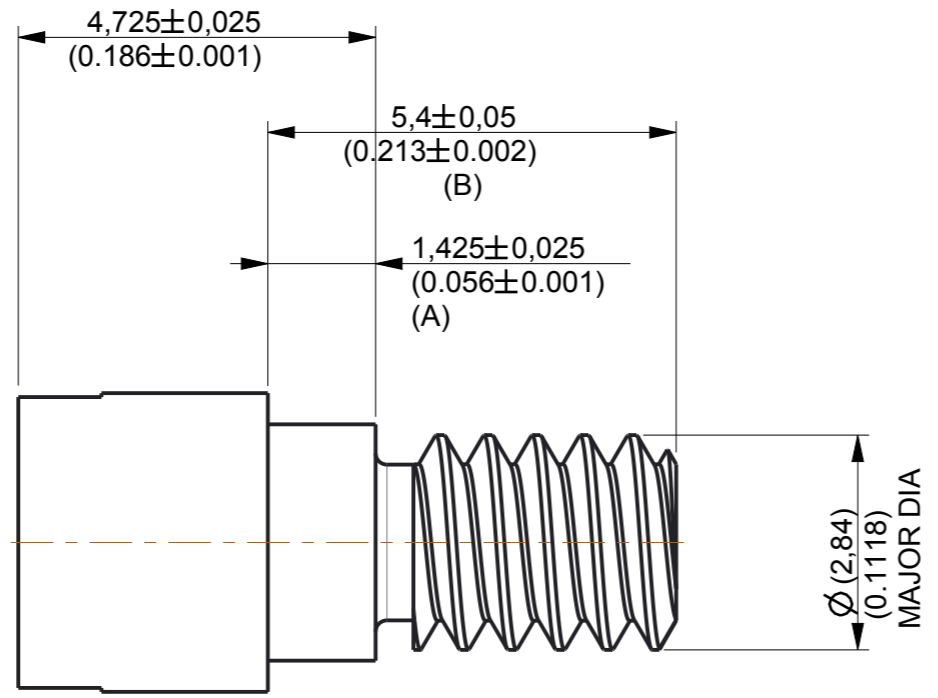

SCALE 5,000

PART NUMBER	SALES_CODE	A	A_IMPERIAL	B	B_IMPERIAL	DESCRIPTION2
DN00008080PAR01	DN00008 08	0,625	0,025	4,600	0,181	2-56UNC REAR PNL J/POST (0.8)
DN00008120PAR01	DN00008 12	1,025	0,040	5,000	0,197	2-56UNC REAR PNL J/POST (1.2)
DN00008160PAR01	DN00008 16	1,425	0,056	5,400	0,213	2-56UNC REAR PNL J/POST (1.6)
DN00008240PAR01	DN00008 24	2,225	0,088	6,200	0,244	2-56UNC REAR PNL J/POST (2.4)
DN00008200PAR01	DN00008 20	1,825	0,072	5,800	0,228	2-56UNC REAR PNL J/POST (2.0)

ISSUE GROUPS  
B



THIS DRAWING IS COPYRIGHT AND IS ISSUED ON CONDITION IT IS NOT COPIED, REPRODUCED OR DISCLOSED TO A THIRD PARTY WITHOUT THE CONSENT IN WRITING OF Cinch CONNECTIVITY SOLUTIONS LTD. ATTENTION IS DRAWN TO THE FACT THE ARTICLE DISCLOSED MAY BE COVERED BY BRITISH OR FOREIGN PATENTS, GRANTED OR PENDING OR REGISTERED DESIGN.

APPD		DATE		NPNR ECN		ISSUE	
		03-Oct-08		PRELIM.		A	
		02-Mar-17		IMP DIMS		C	
GEN. TOLERANCES		±0.1		2 DEC. PL.		±0.1	
TITLE		±0.2		1 DEC. PL.		±0.2	
REAR PANEL MOUNTING JACKPOST		±0.5		0 DEC. PL.		±0.5	
HARDWARE		±1		ANGULAR		±1	
RAW MATL.		0.18		TOOL R. MAX.		0.18	
MATERIAL SPECIFICATION		SCALE		DATE		DRN	
APPD		10,000		30-Jan-09		M.BARRACLOUGH	
APPD		CHD		NOT		NOT	

CODE	DESCRIPTION	ITEM	FINISH/MATL	QTY
	2-56UNC REAR PANEL JACKPOST	2		1
	2-56UNC REAR PANEL JACKPOST	1		1