

# 128-Tap, Nonvolatile, Linear-Taper Digital Potentiometer in 2mm x 2mm $\mu$ DFN Package

## General Description

The MAX5128 nonvolatile, single, linear-taper, digital potentiometer performs the function of a mechanical potentiometer, but replaces the mechanics with a simple 2-wire digital interface. The MAX5128 performs the same function as a discrete potentiometer or variable resistor and features 128 taps and 22k $\Omega$  end-to-end resistance. The MAX5128 also features an ultra-small, 2mm x 2mm  $\mu$ DFN package and low 0.5 $\mu$ A (typ) standby supply current, making this device ideal for portable applications. The MAX5128 operates from a +2.7V to +5.25V power supply. An integrated nonvolatile memory recalls the programmed wiper position of the digital potentiometer. A simple 2-wire up/down interface programs the wiper position. The digital potentiometer provides a low 5ppm/ $^{\circ}$ C ratiometric temperature coefficient and is specified over the extended -40 $^{\circ}$ C to +85 $^{\circ}$ C temperature range.

## Applications

VCOM Adjustment for LCD Panels  
Backlight Adjustment  
LED Bias Adjustment  
Power-Supply Modules  
Fiber-Module Bias Setting  
Bias Setting for Radios  
Portable Consumer Electronics

## Features

- ◆ Ultra-Small, 2mm x 2mm, 8-Pin  $\mu$ DFN Package
- ◆ Power-On Recall of Wiper Position from Nonvolatile Memory
- ◆ 22k $\Omega$  End-to-End Resistance
- ◆ 128 Tap Positions
- ◆ 5ppm/ $^{\circ}$ C Ratiometric Temperature Coefficient
- ◆ 1.5 $\mu$ A (max) Standby Supply Current
- ◆ +2.7V to +5.25V Single Supply Operation
- ◆ 80,000 Wiper Store Cycles
- ◆ 50-Year Wiper Data Retention

## Ordering Information

PART	TEMP RANGE	PIN-PACKAGE	TOP MARK	PKG CODE
MAX5128ELA+	-40 $^{\circ}$ C to +85 $^{\circ}$ C	8 $\mu$ DFN	AAF	L822-1

+Denotes a lead-free package.

## Functional Diagram

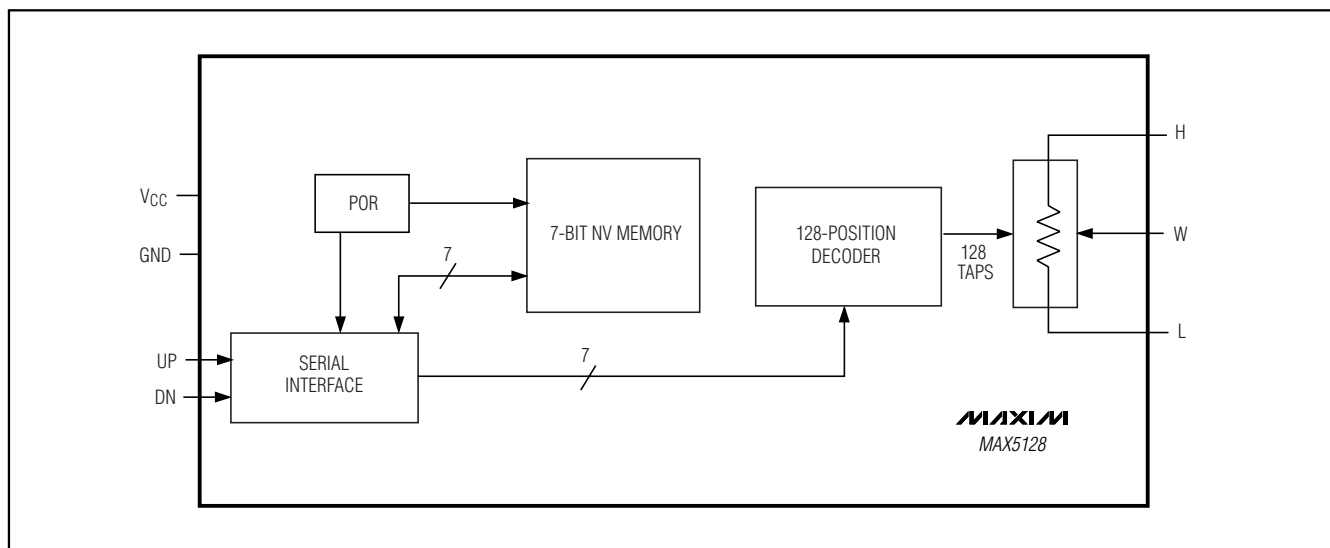

# 128-Tap, Nonvolatile, Linear-Taper Digital Potentiometer in 2mm x 2mm $\mu$ DFN Package

## ABSOLUTE MAXIMUM RATINGS

V<sub>CC</sub> to GND .....-0.3V to +6.0V  
 UP and DN to GND .....-0.3V to (V<sub>CC</sub> + 0.3V)  
 H, L, and W to GND.....-0.3V to (V<sub>CC</sub> + 0.3V)  
 Maximum Continuous Current into H, L, and W .....±0.5mA  
 Maximum Continuous Current into All Other Pins .....±50mA  
 Continuous Power Dissipation (T<sub>A</sub> = +70°C)  
   8-Pin  $\mu$ DFN (derate 4.7mW/°C above +70°C) .....376.5mW

Operating Temperature Range .....-40°C to +85°C  
 Junction Temperature .....+150°C  
 Storage Temperature Range .....-60°C to +150°C  
 Lead Temperature (soldering, 10s) .....+300°C

Stresses beyond those listed under "Absolute Maximum Ratings" may cause permanent damage to the device. These are stress ratings only, and functional operation of the device at these or any other conditions beyond those indicated in the operational sections of the specifications is not implied. Exposure to absolute maximum rating conditions for extended periods may affect device reliability.

## ELECTRICAL CHARACTERISTICS

(V<sub>CC</sub> = +2.7V to +5.25V, H = V<sub>CC</sub>, L = GND, T<sub>A</sub> = -40°C to +85°C. Typical values are at V<sub>CC</sub> = +5.0V, T<sub>A</sub> = +25°C, unless otherwise noted.)  
 (Note 1)

PARAMETER	SYMBOL	CONDITIONS	MIN	TYP	MAX	UNITS
<b>DC PERFORMANCE (voltage-divider mode)</b>						
Resolution	N		7			Bits
Integral Nonlinearity	INL	(Note 2)			±1.0	LSB
Differential Nonlinearity	DNL	(Note 2)			±1.0	LSB
End-to-End Resistance Temperature Coefficient	TC <sub>R</sub>			50		ppm/°C
Ratiometric Resistance Temperature Coefficient				5		ppm/°C
Full-Scale Error	FSE		-3		0	LSB
Zero-Scale Error	ZSE		0		+2	LSB
<b>DC PERFORMANCE (variable-resistor mode)</b>						
Integral Nonlinearity	INL	(Note 3)			±1.75	LSB
Differential Nonlinearity	DNL	(Note 3)			±1	LSB
<b>DC PERFORMANCE (resistor characteristics)</b>						
Wiper Resistance	R <sub>W</sub>	(Note 4)		0.6	0.8	k $\Omega$
Wiper Capacitance	C <sub>W</sub>			20		pF
End-to-End Resistance	R <sub>HL</sub>		16	22	27	k $\Omega$
<b>DIGITAL INPUTS (UP, DN)</b>						
Input-High Voltage (Note 5)	V <sub>IH</sub>	3.4V $\leq$ V <sub>CC</sub> $\leq$ 5.25V	2.4			V
		2.7V $\leq$ V <sub>CC</sub> < 3.4V	0.7 x V <sub>CC</sub>			
Input-Low Voltage	V <sub>IL</sub>	(Note 5)			0.8	V
Input Leakage Current	I <sub>IN</sub>				±1	$\mu$ A
Input Capacitance	C <sub>IN</sub>			5		pF
<b>DYNAMIC CHARACTERISTICS</b>						
Wiper -3dB Bandwidth	f <sub>3dB</sub>	(Note 6)		400		kHz
THD Plus Noise	THD+N	V <sub>H</sub> = 0.3V <sub>RMS</sub> , f = 1kHz, wiper set to midscale		0.02		%

# 128-Tap, Nonvolatile, Linear-Taper Digital Potentiometer in 2mm x 2mm $\mu$ DFN Package

MAX5128

## ELECTRICAL CHARACTERISTICS (continued)

( $V_{CC} = +2.7V$  to  $+5.25V$ ,  $H = V_{CC}$ ,  $L = GND$ ,  $T_A = -40^{\circ}C$  to  $+85^{\circ}C$ . Typical values are at  $V_{CC} = +5.0V$ ,  $T_A = +25^{\circ}C$ , unless otherwise noted.) (Note 1)

PARAMETER	SYMBOL	CONDITIONS	MIN	TYP	MAX	UNITS
<b>NONVOLATILE MEMORY RELIABILITY</b>						
Data Retention		$T_A = +85^{\circ}C$		50		Years
Endurance		$T_A = +25^{\circ}C$		80,000		Stores
		$T_A = +85^{\circ}C$		50,000		
<b>POWER SUPPLY</b>						
Supply Voltage	$V_{CC}$		2.70		5.25	V
Average Programming Current	$I_{PG}$	During nonvolatile write only; digital inputs = $V_{CC}$ or GND		220	400	$\mu A$
Peak Programming Current	$I_{PK}$	During nonvolatile write only; digital inputs = $V_{CC}$ or GND		4		mA
Standby Current	$I_{CC}$	Digital inputs = $V_{CC}$ or GND, $T_A = +25^{\circ}C$		0.5	1.5	$\mu A$

## TIMING CHARACTERISTICS

( $V_{CC} = +2.7V$  to  $+5.25V$ ,  $H = V_{CC}$ ,  $L = GND$ ,  $T_A = -40^{\circ}C$  to  $+85^{\circ}C$ . Typical values are at  $V_{CC} = +5.0V$ ,  $T_A = +25^{\circ}C$ , unless otherwise noted.) (See Figures 1, 2, 3, and 4).

PARAMETER	SYMBOL	CONDITIONS	MIN	TYP	MAX	UNITS
<b>ANALOG SECTION</b>						
Wiper Settling Time	$t_S$	(Note 7)		500		ns
<b>DIGITAL SECTION</b>						
UP or DN Pulse-Width High	$t_{PWH}$		80			ns
UP or DN Pulse-Width Low	$t_{PWL}$		80			ns
UP or DN Glitch Immunity	$t_{IMMU}$		20			ns
UP Fall to DN Rise Setup or DN Fall to UP Rise Setup	$t_{MS1}$		80			ns
Before Entering NVM-Write Mode, UP Fall to UP Rise	$t_{MS2}$		80			ns
UP Rise to DN Rise Setup when Entering NVM-Write	$t_{WS}$		80			ns
UP Fall to DN Fall Hold or DN Fall to UP Fall Hold during NVM-Write	$t_{WH}$		0			ns

# 128-Tap, Nonvolatile, Linear-Taper Digital Potentiometer in 2mm x 2mm $\mu$ DFN Package

## TIMING CHARACTERISTICS (continued)

( $V_{CC} = +2.7V$  to  $+5.25V$ ,  $H = V_{CC}$ ,  $L = GND$ ,  $T_A = -40^{\circ}C$  to  $+85^{\circ}C$ . Typical values are at  $V_{CC} = +5.0V$ ,  $T_A = +25^{\circ}C$ , unless otherwise noted.) (See Figures 1, 2, 3, and 4).

PARAMETER	SYMBOL	CONDITIONS	MIN	TYP	MAX	UNITS
NVM-Write Mode Pulse-Width High	$t_{WP}$		80			ns
Write NV Register Busy Time	$t_{BUSY}$				14	ms
Power-Up Settling Time	$t_{ACC}$	(Note 8)		2		$\mu$ s

**Note 1:** All devices are production tested at  $T_A = +25^{\circ}C$  and are guaranteed by design for  $T_A = -40^{\circ}C$  to  $+85^{\circ}C$ .

**Note 2:** The DNL and INL are measured with the potentiometer configured as a voltage-divider with  $H = V_{CC}$  and  $L = GND$ . The wiper terminal is unloaded and measured with a high input-impedance voltmeter.

**Note 3:** The DNL and INL are measured with the potentiometer configured as a variable resistor.  $H$  is unconnected and  $L = GND$ . For the  $+5V$  condition, the wiper terminal is driven with a source current of  $200\mu A$  and for the  $+2.7V$  condition, the wiper terminal is driven with a source current of  $100\mu A$ .

**Note 4:** The wiper resistance is measured using the source currents given in Note 3.

**Note 5:** The device draws higher supply current when the digital inputs are driven with voltages between  $(V_{CC} - 0.5V)$  and  $(GND + 0.5V)$ . See Supply Current vs. Digital Input Voltage in the *Typical Operating Characteristics*.

**Note 6:** Wiper at midscale with a  $10pF$  load,  $L = GND$ , an AC source is applied to  $H$ , and the output is measured as 3dB lower than the DC W/H value in dB.

**Note 7:** Wiper-settling time is the worst-case 0 to 50% rise time measured between consecutive wiper positions.  $H = V_{CC}$ ,  $L = GND$ , and the wiper terminal is unloaded and measured with a  $10pF$  oscilloscope probe. See the Tap-to-Tap Switching Transient in the *Typical Operating Characteristics* section.

**Note 8:** Power-up settling time is measured from the time  $V_{CC} = 2.7V$  to the wiper settling to 1 LSB of the final value.

# 128-Tap, Nonvolatile, Linear-Taper Digital Potentiometer in 2mm x 2mm $\mu$ DFN Package

## Typical Operating Characteristics

( $V_{CC} = +5.0V$ ,  $T_A = +25^\circ C$ , unless otherwise noted.)

MAX5128

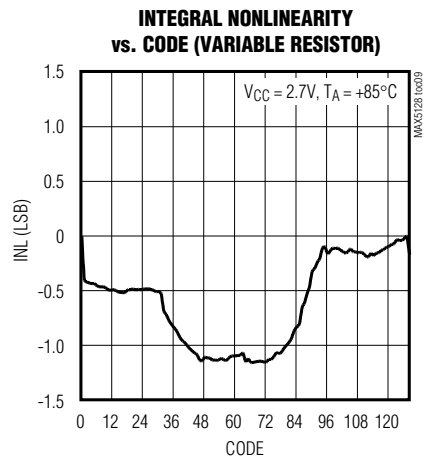
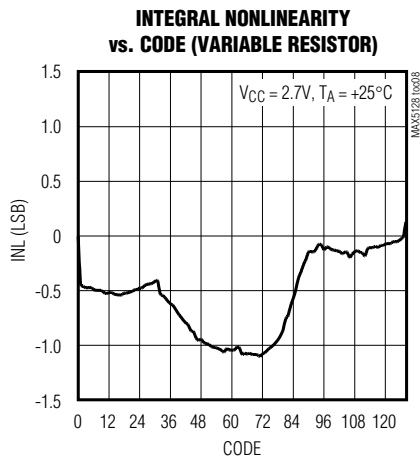
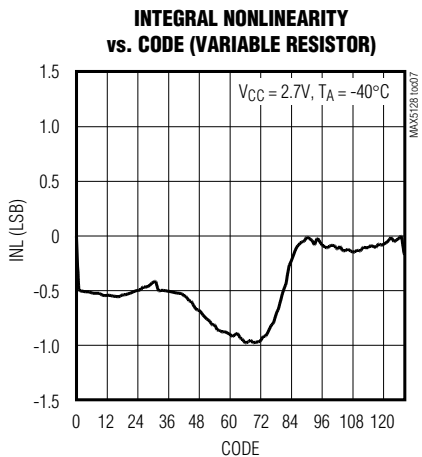
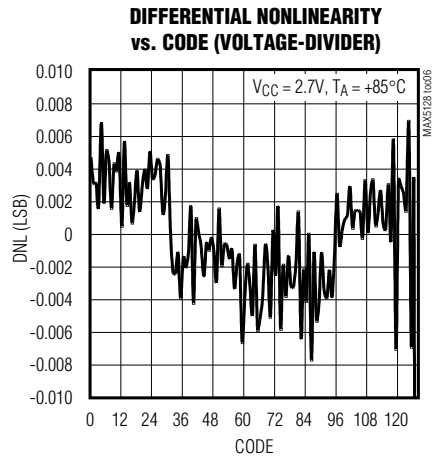
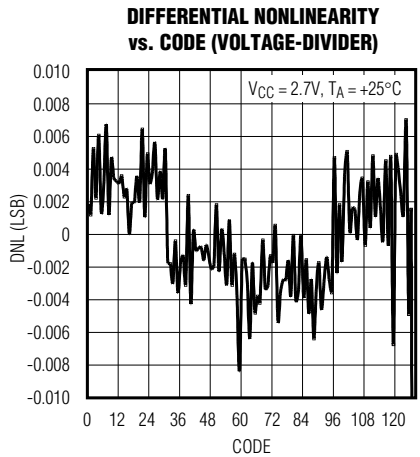
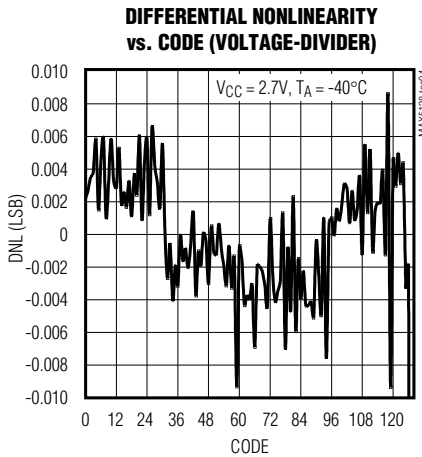
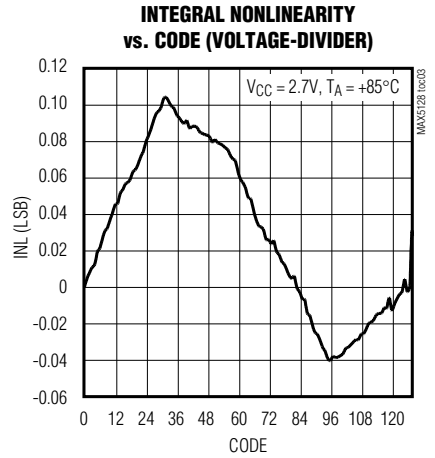
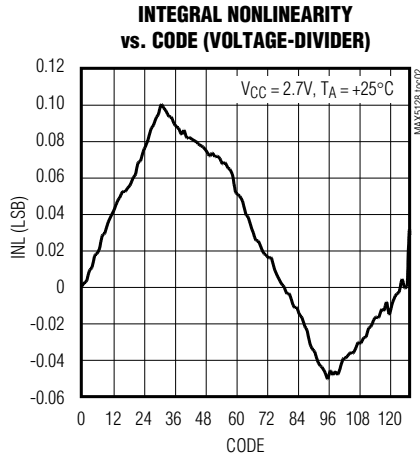
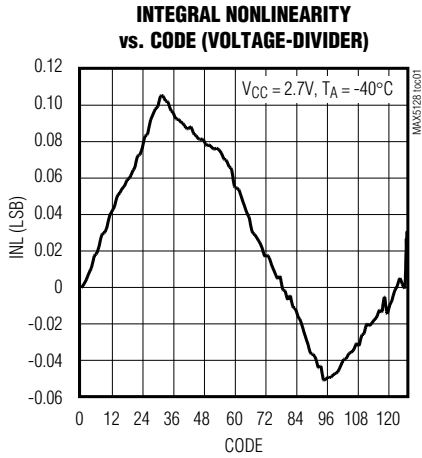

# 128-Tap, Nonvolatile, Linear-Taper Digital Potentiometer in 2mm x 2mm $\mu$ DFN Package

## Typical Operating Characteristics (continued)

( $V_{CC} = +5.0V$ ,  $T_A = +25^\circ C$ , unless otherwise noted.)

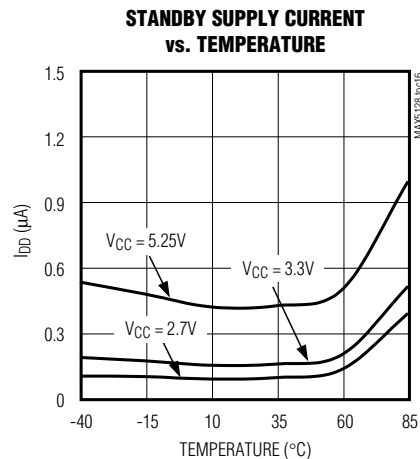
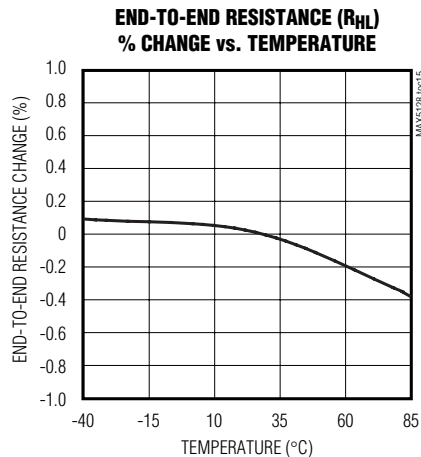
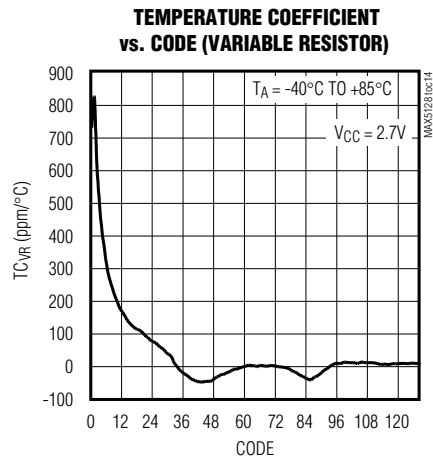
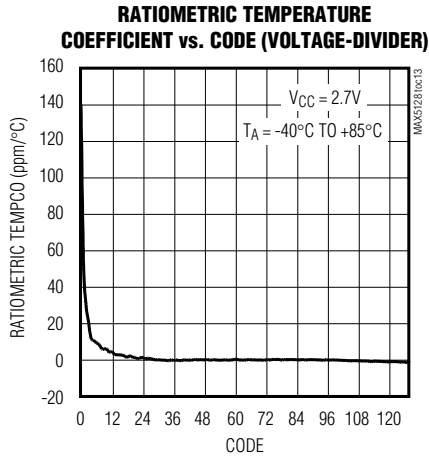
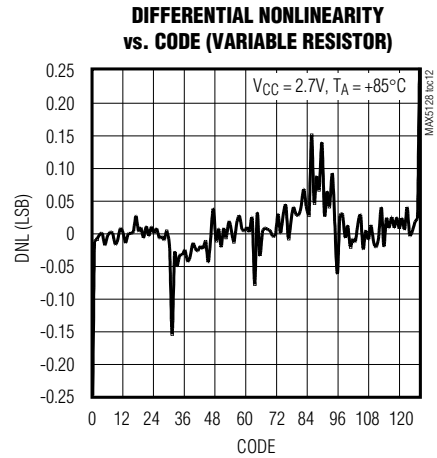
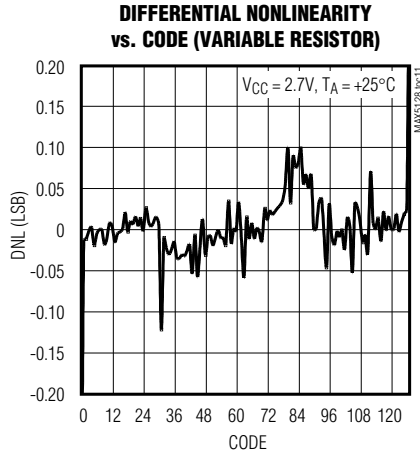
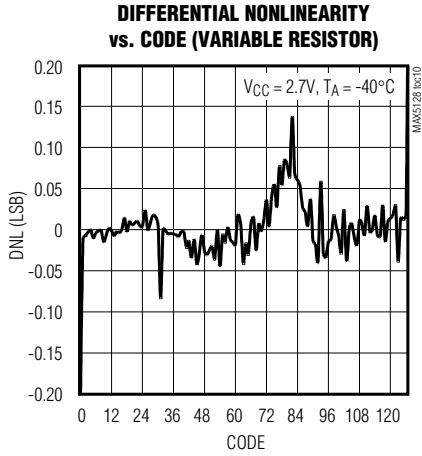

# 128-Tap, Nonvolatile, Linear-Taper Digital Potentiometer in 2mm x 2mm $\mu$ DFN Package

MAX5128

## Typical Operating Characteristics (continued)

( $V_{CC} = +5.0V$ ,  $T_A = +25^\circ C$ , unless otherwise noted.)

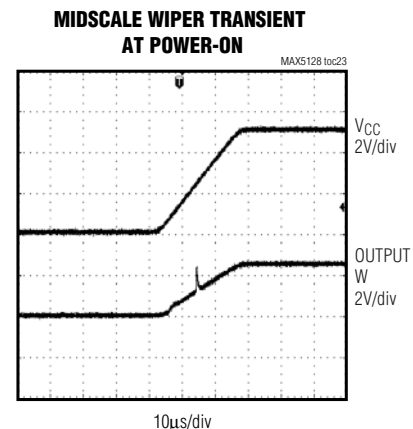
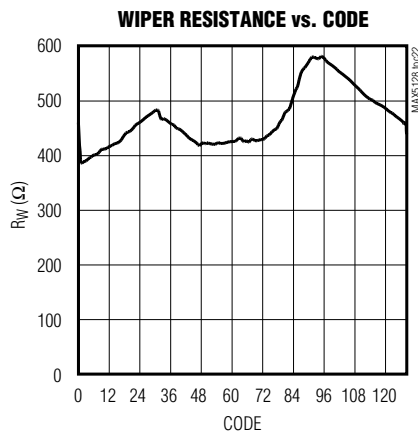
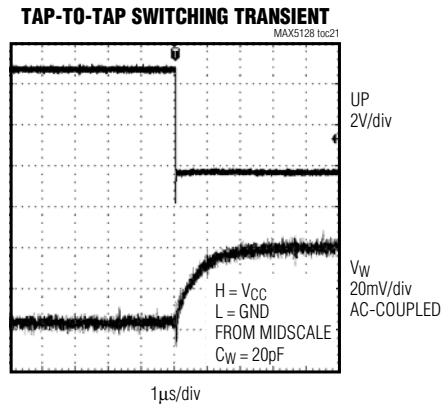
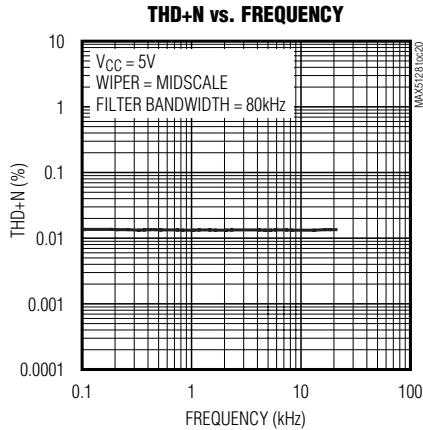
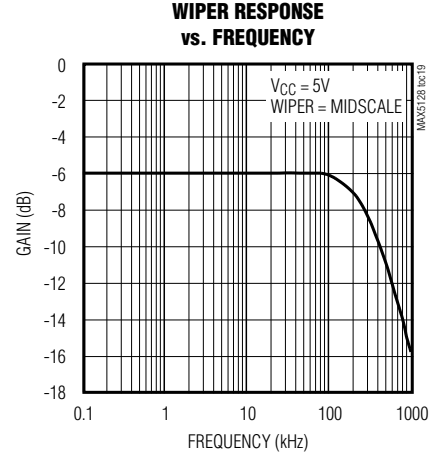
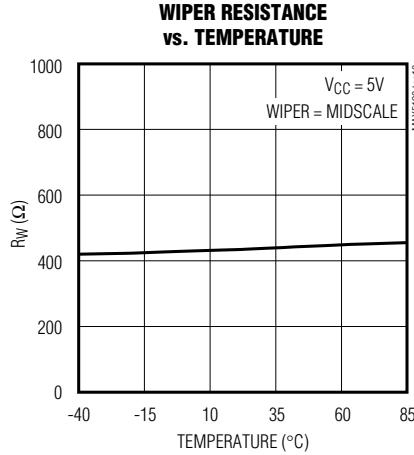
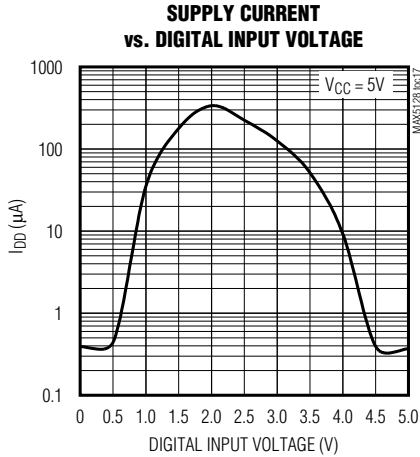

# 128-Tap, Nonvolatile, Linear-Taper Digital Potentiometer in 2mm x 2mm $\mu$ DFN Package

## Pin Description

PIN	NAME	FUNCTION
1	V <sub>CC</sub>	Power Supply. Bypass V <sub>CC</sub> with a 0.1 $\mu$ F capacitor to GND as close to the device as possible. For proper operation, limit the supply voltage slew rate to $\geq 10\mu$ s.
2	H	High Terminal. The voltage at H can be higher than or lower than the voltage at L. Current can flow into or out of H.
3	W	Wiper Terminal
4	L	Low Terminal. The voltage at L can be higher than or lower than the voltage at H. Current can flow into or out of L.
5	GND	Ground
6	DN	Down Input
7	UP	Up Input
8	N.C.	No Connection. Not internally connected.

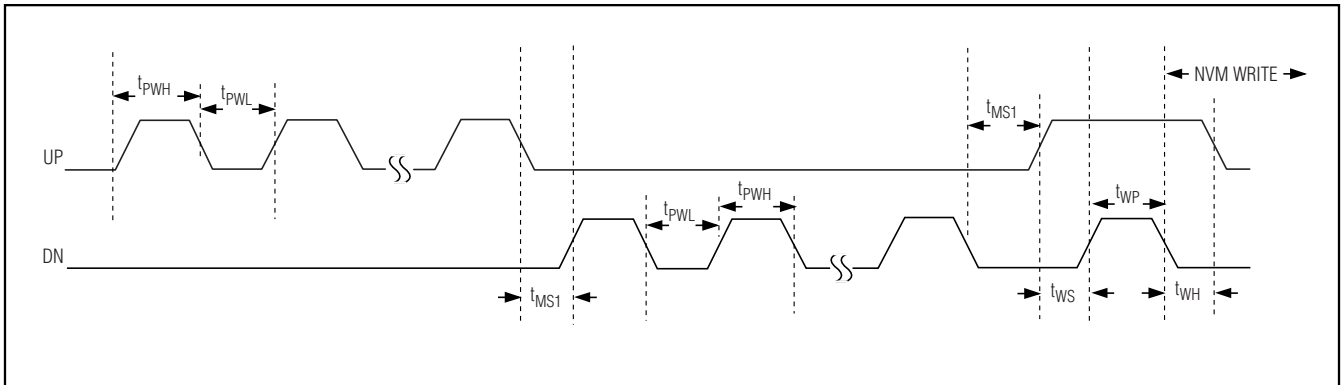

Figure 1. Digital-Interface Timing Diagram

## Detailed Description

The MAX5128 nonvolatile, single, linear-taper, digital potentiometer performs the function of a mechanical potentiometer or variable resistor, but replaces the mechanics with a simple 2-wire digital interface. This device features 128 taps and 22k $\Omega$  end-to-end resistance with a 5ppm/ $^{\circ}$ C ratiometric temperature coefficient. The MAX5128 operates from a +2.7V to +5.25V power supply and consumes only 0.5 $\mu$ A (typ) of standby supply current. The MAX5128 includes an integrated nonvolatile memory that recalls the stored wiper position of the digital potentiometer. A simple 2-wire up/down interface programs the wiper positions.

## Analog Circuitry

The MAX5128 consists of a resistor array with 127 resistive elements; 128 tap points along the resistor string between H and L are accessible to the wiper, W. Select the wiper tap point by programming the potentiometer through the 2-wire (UP, DN) interface.

The MAX5128 features power-on reset circuitry that loads the wiper position from the nonvolatile memory at power-up.

The nonvolatile memory is programmed to midscale at the factory.



# 128-Tap, Nonvolatile, Linear-Taper Digital Potentiometer in 2mm x 2mm $\mu$ DFN Package

MAX5128

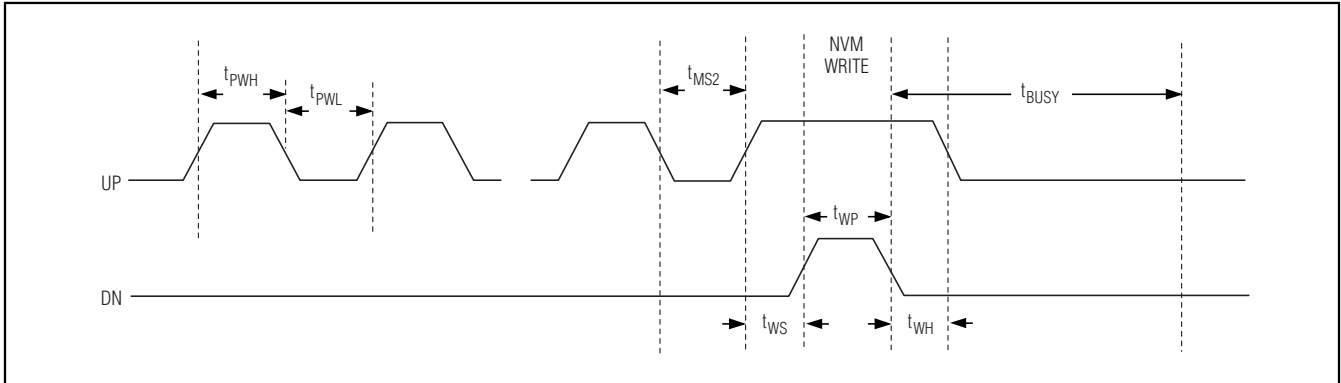

Figure 2. Digital-Interface Timing Diagram with  $t_{BUSY}$

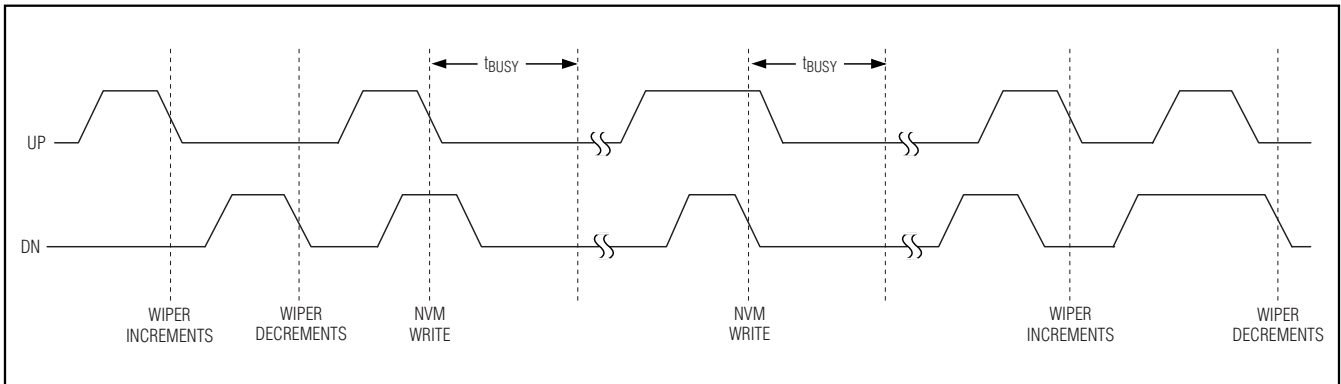

Figure 3. Digital-Interface Command Diagram

## Digital Interface

The MAX5128 features a 2-wire interface consisting of two logic inputs (UP and DN). Logic inputs UP and DN control the wiper position and program the position to the nonvolatile memory. Transition UP from high to low with DN low to increment the wiper position. Transition DN from high to low with UP low to decrement the wiper position (see Figures 1, 2, and 3). When the wiper decrements, it decreases the resistance between W and L (and it increases the resistance between H and W).

To program the nonvolatile memory, force UP high, then force DN high, and then transition either input (UP/DN) from high to low (see Figure 3).

The wiper performs a make-before-break transition, ensuring that an open circuit during a transition from one resistor tap to another does not occur. The wiper does not wrap around when it reaches either end of the resistor array (max/min). Additional transition com-

mands in the direction of the end point do not change the tap position.

The logic inputs also feature pulse glitch immunity (20ns) to protect the wiper from transitioning due to glitches (see Figure 4).

## Write NV Register

The internal EEPROM consists of a 7-bit nonvolatile memory that retains the value written to it even after power-down. To program the nonvolatile memory, force UP high, then force DN high, and then transition either input (UP/DN) from high to low. A nonvolatile write requires a busy time of 14ms (max). During the busy time, any nonvolatile write requests are ignored as well as requests to increment or decrement the wiper position. Upon power-up, the wiper returns to the position stored in the nonvolatile register. The MAX5128 features a factory-default wiper position of midscale.

# 128-Tap, Nonvolatile, Linear-Taper Digital Potentiometer in 2mm x 2mm $\mu$ DFN Package

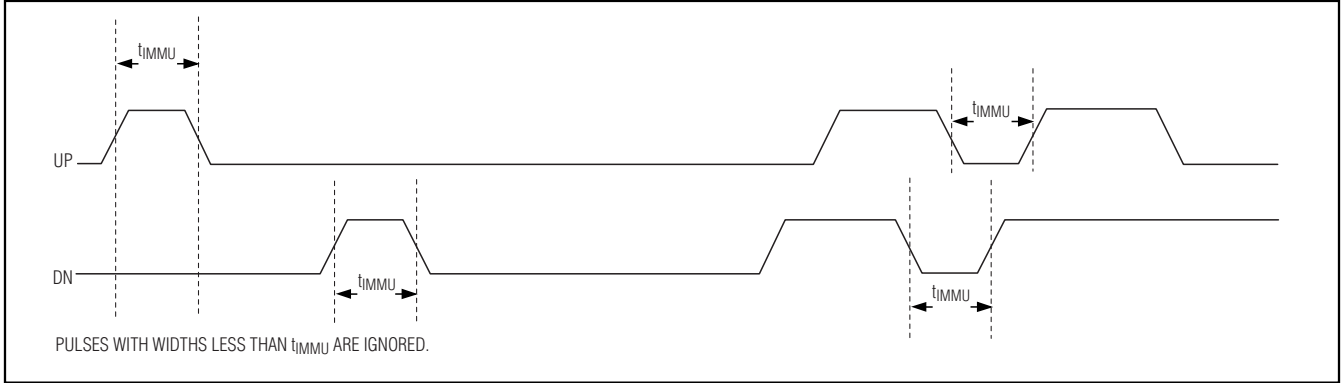

Figure 4. Glitch-Immunity Timing Diagram

### Standby Mode

The MAX5128 operates in standby mode while the serial interface is inactive. Programming the MAX5128 increases the average operating current to 400 $\mu$ A (max). When in standby mode, the static supply current reduces to less than 0.5 $\mu$ A (typ).

### Power-Up

Upon power-up, the MAX5128 updates the wiper position with the data stored in the nonvolatile memory. This initialization period takes 2 $\mu$ s (typ). For proper operation, limit the supply voltage slew rate to  $\geq 10\mu$ s.

### Applications Information

Use the MAX5128 for applications requiring digitally controlled adjustable resistance or voltage, such as LCD contrast control (where voltage biasing adjusts the display contrast), or DC-DC converters with adjustable outputs. The 22k $\Omega$  end-to-end resistance is divided into 128 tap points of 172 $\Omega$  each. Use the MAX5128 in a voltage-divider or variable-resistor configuration.

### V<sub>COM</sub> Generator

Figure 5 shows an application using the MAX4238 and the MAX5128 to generate the V<sub>COM</sub> voltage for a LCD panel. Adjusting the resistor value of the MAX5128 changes the V<sub>COM</sub> voltage. Adjusting the V<sub>COM</sub> voltage changes the contrast for the LCD panel.

### DC-DC Converter Applications

Figures 6 and 7 show two applications using the MAX5128 to adjust the output voltage of a DC-DC converter. Figure 6 shows the MAX5128 in the grounded potentiometer configuration. Figure 7 shows the MAX5128 in a floating potentiometer configuration. The grounded potentiometer configuration forces the output voltage range of the DC-DC converter to fall within the supply voltage range of the MAX5128. Use the floating potentiometer configuration to allow the DC-DC converter's output to exceed the supply voltage range of the MAX5128. The floating potentiometer configuration increases the output voltage range and increases the precision of the output voltage adjustment range.

### LED Bias Adjustment

Figure 8 shows a LED bias adjustment application using a MAX5128 to set the current of the LEDs that the MAX1574 drives. Use the MAX5128 for an adjustable LED current drive of 10mA to 60mA.

### Chip Information

PROCESS: BICMOS

# 128-Tap, Nonvolatile, Linear-Taper Digital Potentiometer in 2mm x 2mm $\mu$ DFN Package

MAX5128

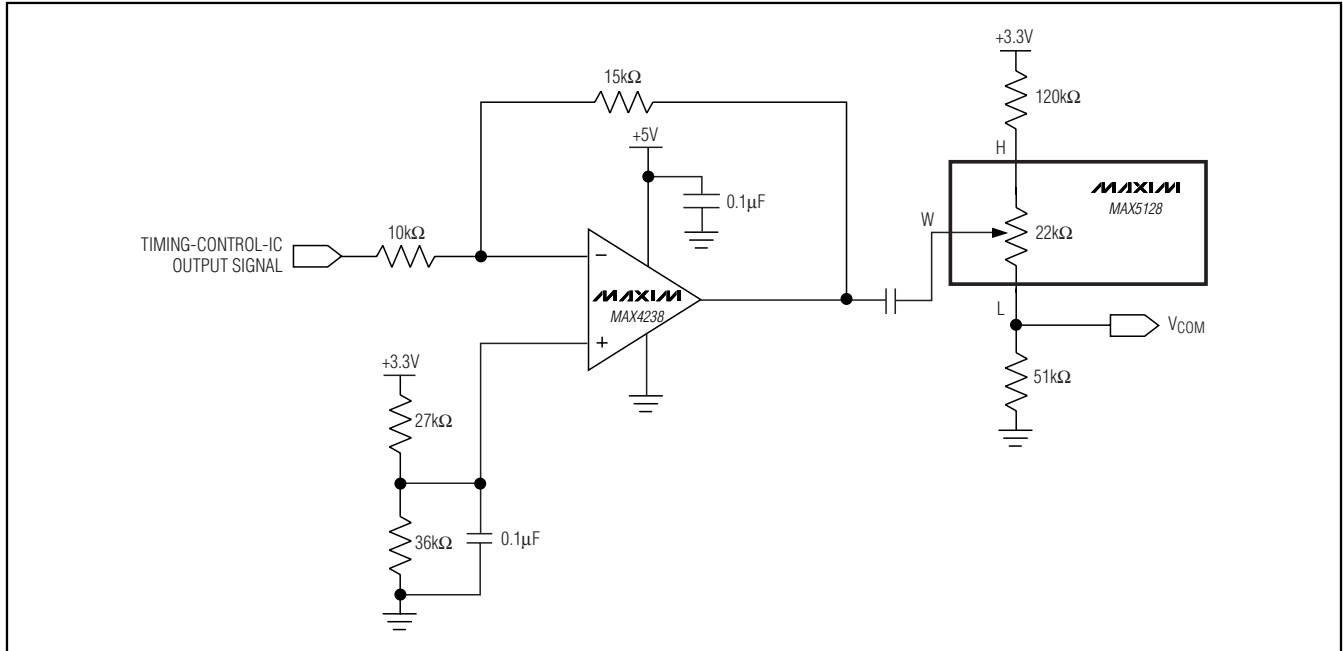

Figure 5. VCOM Generator Circuit for LCD Panels

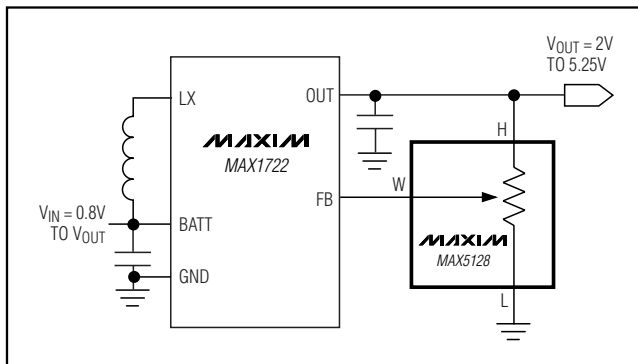

Figure 6. DC-DC Converter Using a Grounded Potentiometer

# 128-Tap, Nonvolatile, Linear-Taper Digital Potentiometer in 2mm x 2mm $\mu$ DFN Package

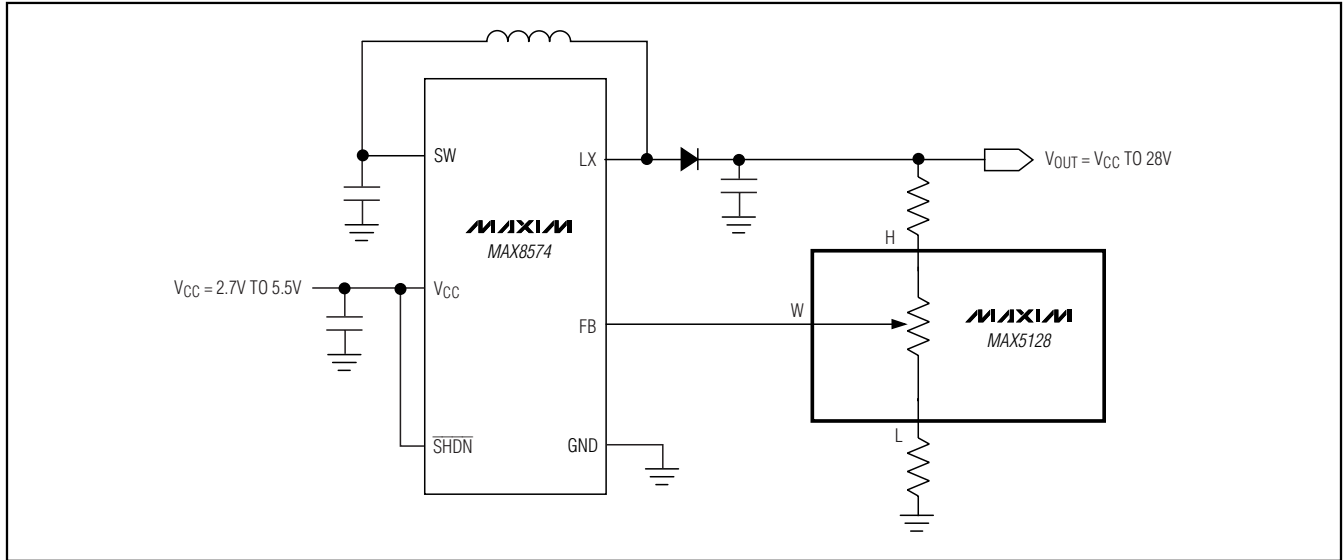

Figure 7. DC-DC Converter Using a Floating Potentiometer

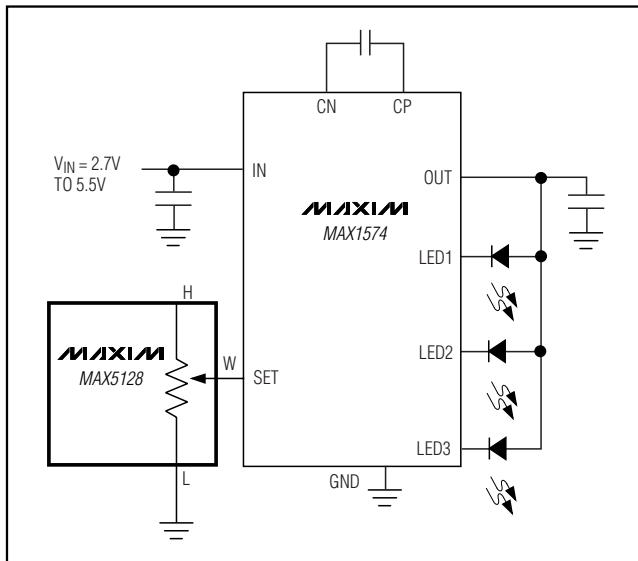
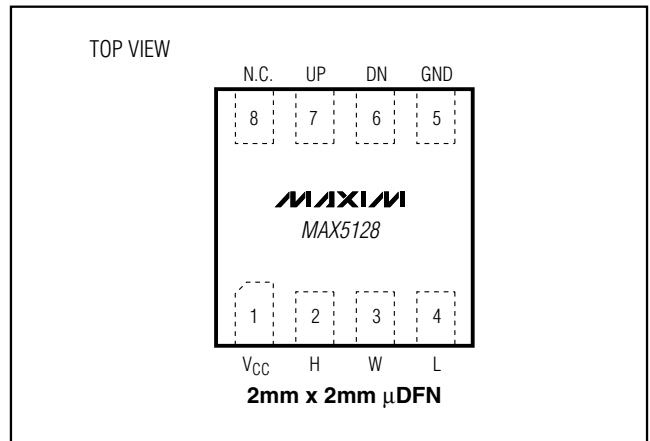

Figure 8. LED Bias Adjustment Using the MAX5128

## Pin Configuration



# 128-Tap, Nonvolatile, Linear-Taper Digital Potentiometer in 2mm x 2mm $\mu$ DFN Package

## Package Information

(The package drawing(s) in this data sheet may not reflect the most current specifications. For the latest package outline information, go to [www.maxim-ic.com/packages](http://www.maxim-ic.com/packages).)

**MAX5128**

6, 8, 10L uDFN:EPS

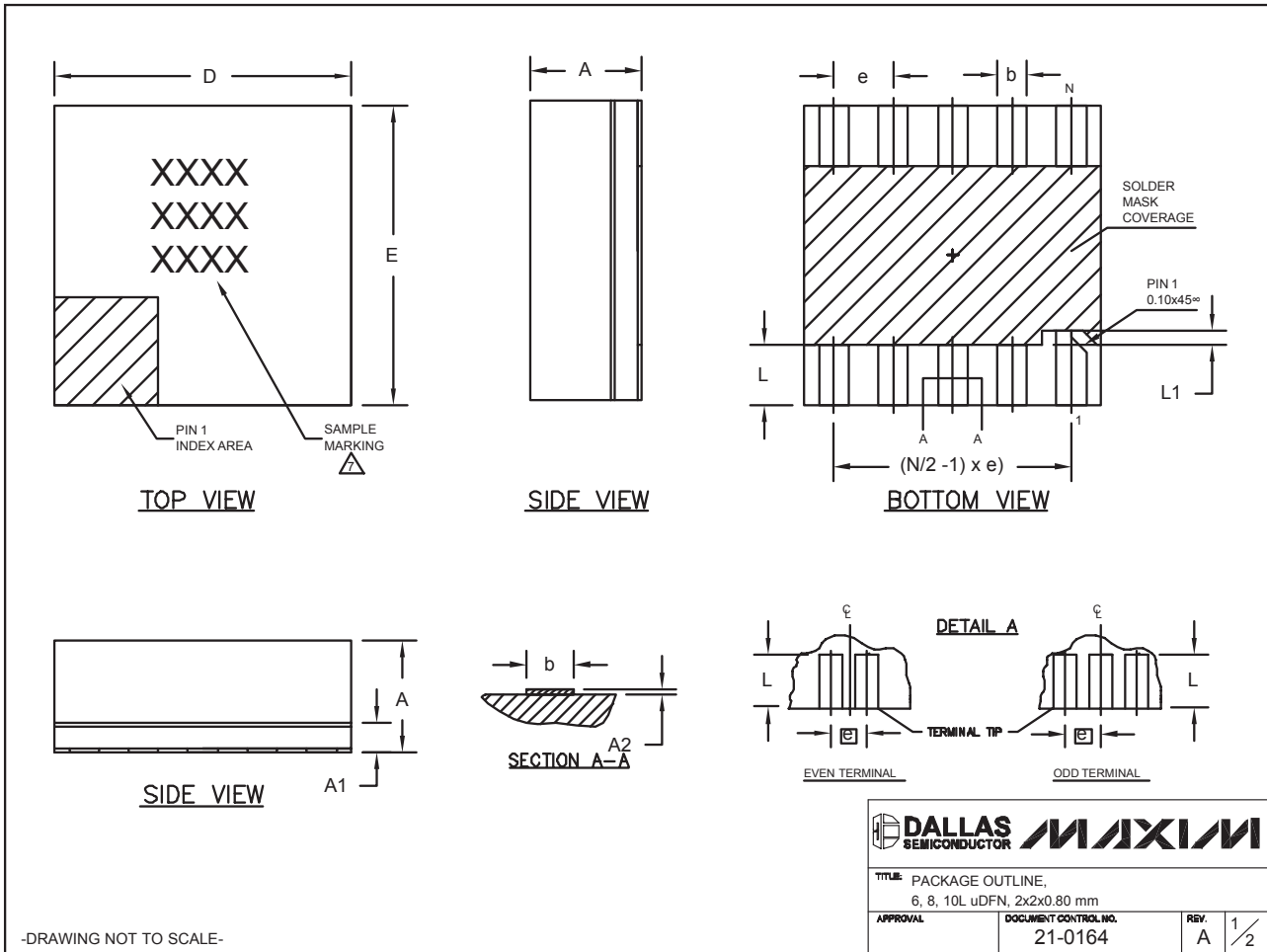

# 128-Tap, Nonvolatile, Linear-Taper Digital Potentiometer in 2mm x 2mm $\mu$ DFN Package

## Package Information (continued)

(The package drawing(s) in this data sheet may not reflect the most current specifications. For the latest package outline information, go to [www.maxim-ic.com/packages](http://www.maxim-ic.com/packages).)

COMMON DIMENSIONS			
SYMBOL	MIN.	NOM.	MAX.
A	0.70	0.75	0.80
A1	0.15	0.20	0.25
A2	0.020	0.025	0.035
D	1.95	2.00	2.05
E	1.95	2.00	2.05
L	0.30	0.40	0.50
L1	0.10 REF.		

PACKAGE VARIATIONS				
PKG. CODE	N	e	b	(N/2 -1) x e
L622-1	6	0.65 BSC	0.30±0.05	1.30 REF.
L822-1	8	0.50 BSC	0.25±0.05	1.50 REF.
L1022-1	10	0.40 BSC	0.20±0.03	1.60 REF.

### NOTES:

1. ALL DIMENSIONS ARE IN mm. ANGLES IN DEGREES.
  2. COPLANARITY SHALL NOT EXCEED 0.08mm.
  3. WARPAGE SHALL NOT EXCEED 0.10mm.
  4. PACKAGE LENGTH/PACKAGE WIDTH ARE CONSIDERED AS SPECIAL CHARACTERISTIC(S).
  5. "N" IS THE TOTAL NUMBER OF LEADS.
  6. NUMBER OF LEADS SHOWN ARE FOR REFERENCE ONLY.
-  MARKING IS FOR PACKAGE ORIENTATION REFERENCE ONLY.

-DRAWING NOT TO SCALE-

			
TITLE: PACKAGE OUTLINE, 6, 8, 10L $\mu$ DFN, 2x2x0.80 mm			
APPROVAL	DOCUMENT CONTROL NO. 21-0164	REV. A	2/2

## Revision History

Pages changed at Rev 1: 1, 9, 10, 13

Pages changed at Rev 2: 1, 9–14

Maxim cannot assume responsibility for use of any circuitry other than circuitry entirely embodied in a Maxim product. No circuit patent licenses are implied. Maxim reserves the right to change the circuitry and specifications without notice at any time.

14 **Maxim Integrated Products, 120 San Gabriel Drive, Sunnyvale, CA 94086 408-737-7600**