

PART NUMBER	CONTACT AREA PLATING
10078837-001LF	0.75um GOLD
10078837-001FLF	GOLD FLASH

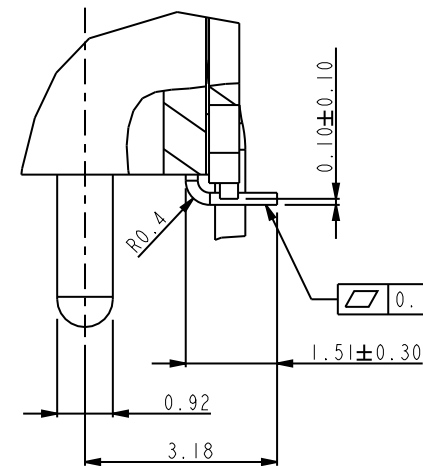

DETAIL A
SCALE 8.000

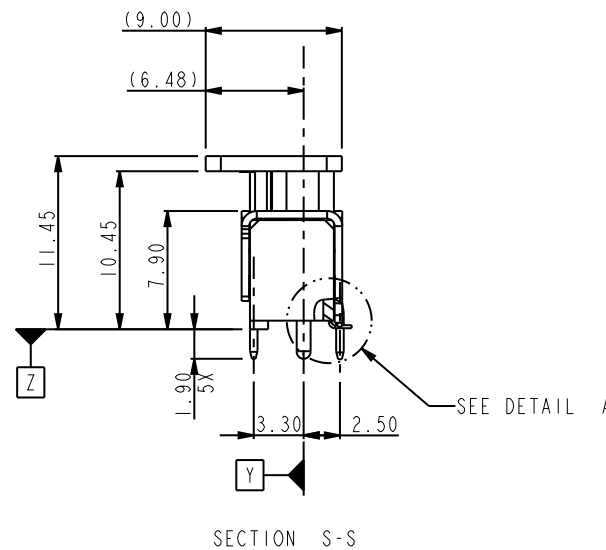
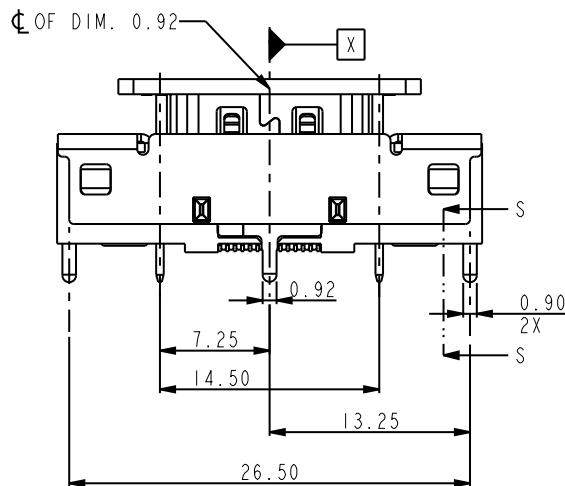
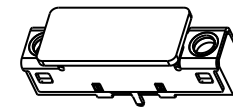
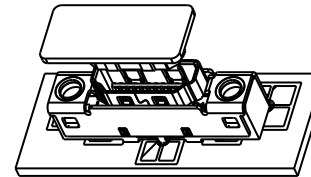
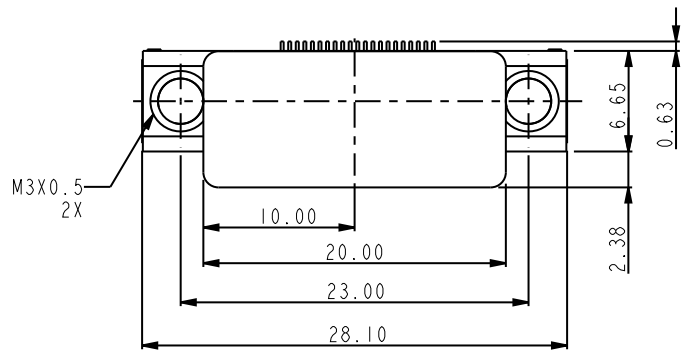
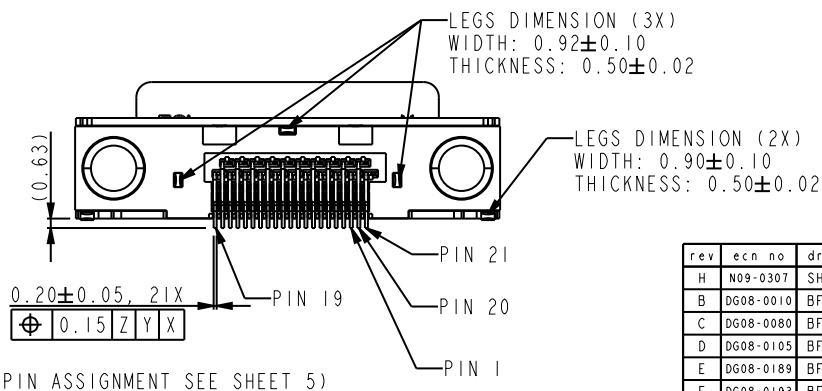

rev	ecn no	dr	date
H	N09-0307	SH	102109
B	0608-0010	BF	122407
C	0608-0080	BF	040808
D	0608-0105	BF	050508
E	0608-0189	BF	072108
F	0608-0193	BF	072908
G	N09-0142	BF	051209

www.fciconnect.com		surface	<input checked="" type="checkbox"/>	tolerance std	projection	MM
		TOLERANCES UNLESS OTHERWISE SPECIFIED				
Dr	BEER FU	061107	ANGULAR	0.X	±0.30	size A4
Eng	BEER FU	061107	LINEAR	0.XX	±0.15	Scale 1.000
Chr	PAUL WANG	061107	0°	0.XXX	±0.08	ECN N09-0142
Appr	JOSEPH HSIA	061107	Product family		Spec ref *	
		title		ASSEMBLY		dwg no
				HDMI BOARD CONNECTOR, VERTICAL TYPE		10078837
		catalog no		CUSTOMER		Rev. H
				sheet 1 of 5		



Copyright FCI.

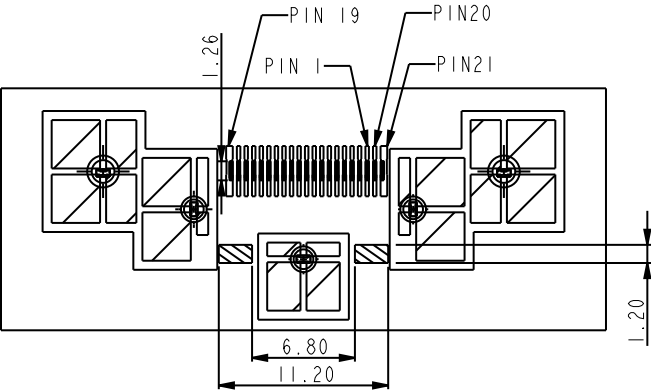
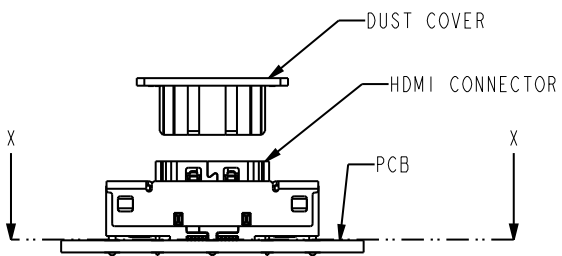

- SOLDER TAIL JOINTS (21X)
- METAL POSTS (5X)
- PLASTIC STANDOFF (2X)

SECTION X-X
SCALE 2.000

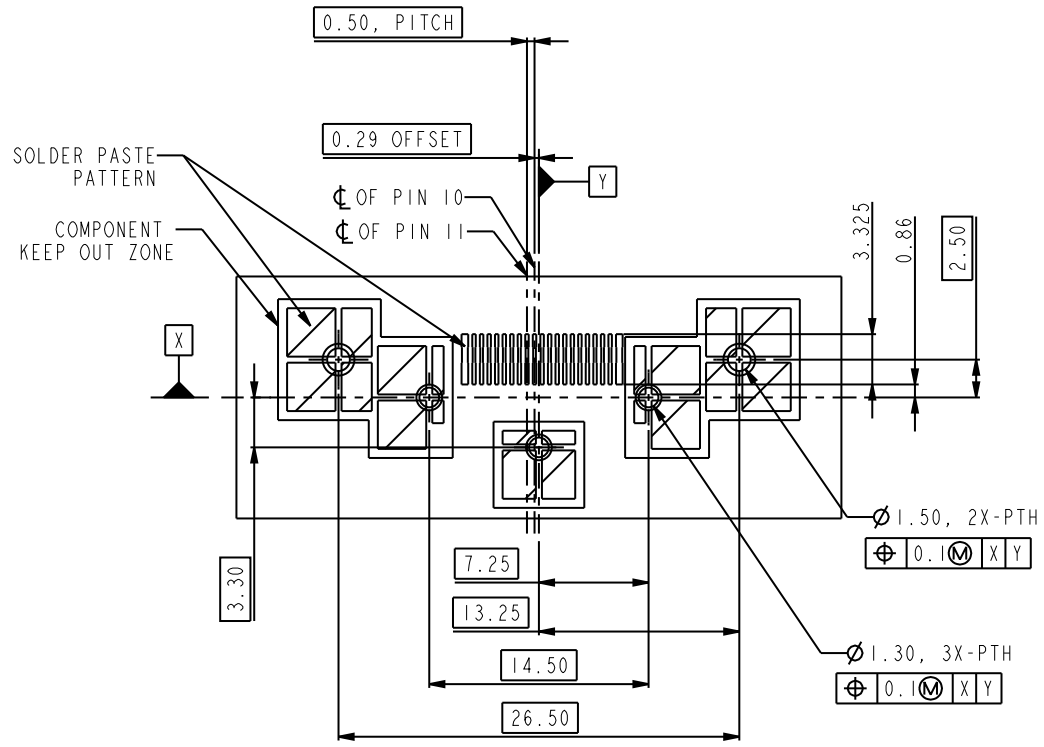

SOLDER PASTE PATTERN
AND PCB LAYOUT
THICKNESS=1.6MM
(SEE DETAIL DIMENSION IN SHEET 3&4)

NOTES:

1. MATERIAL
 - 1-1 HOUSING: GLASS FILLED HIGH-TEMP. RESIN (UL94V-0)
 - 1-2 CONTACT: COPPER ALLOY
 - 1-3 MAJOR SHELL: STAINLESS STEEL
 - 1-4 SECOND SHELL: STAINLESS STEEL
2. FINISH
 - 2-1 CONTACT: Ni UNDER PLATED ALL OVER
CONTACT AREA:
 - 2-1-1) PART NUMBER 10078837-001LF: 0.75 MICROMETER Au MIN.
 - 2-1-2) PART NUMBER 10078837-001FLF: GOLD FLASH.
SMT TAIL 1.27 MICROMETER MATTE TIN.
 - 2-2 MAJOR SHELL: Ni PLATED, 0.75 MICROMETERS MIN.
 - 2-3 SECOND SHELL: Ni PLATED, 0.75 MICROMETERS MIN.
3. PACKAGING:
 - PACKAGING SPECIFICATION GS-14-939
4. RoHS STANDARD SPECIFICATION ACCORDING TO FCI GS-22-008.
5. PARTS MEET REFLOW APPLICATION PEAK TEMP. 260 DEGREE C, 10 SECONDS MAX.
PIN IN PASTE REFLOW APPLICATION IS RECOMMENDED.
6. PRODUCT SPECIFICATION REFERENCE FCI GS-12-309.

www.fciconnect.com			surface	<input checked="" type="checkbox"/>	tolerance std	projection	MM	
			TOLERANCES UNLESS OTHERWISE SPECIFIED					
Dr	BEER FU	061107	ANGULAR	LINEAR	0.X	±0.30	size A4	Scale 1.000
Eng	BEER FU	061107			0.XX	±0.15		
Chr	PAUL WANG	061107	0°	±2°	0.XXX	±0.08	ECN	N09-0142
Appr	JOSEPH HSIA	061107	Product family		-	Spec ref		*
			title ASSEMBLY			dwg no 10078837		Rev. H
			catalog no -			CUSTOMER		sheet 2 of 5

REV F - 2006-04-17



Copyright FCI.

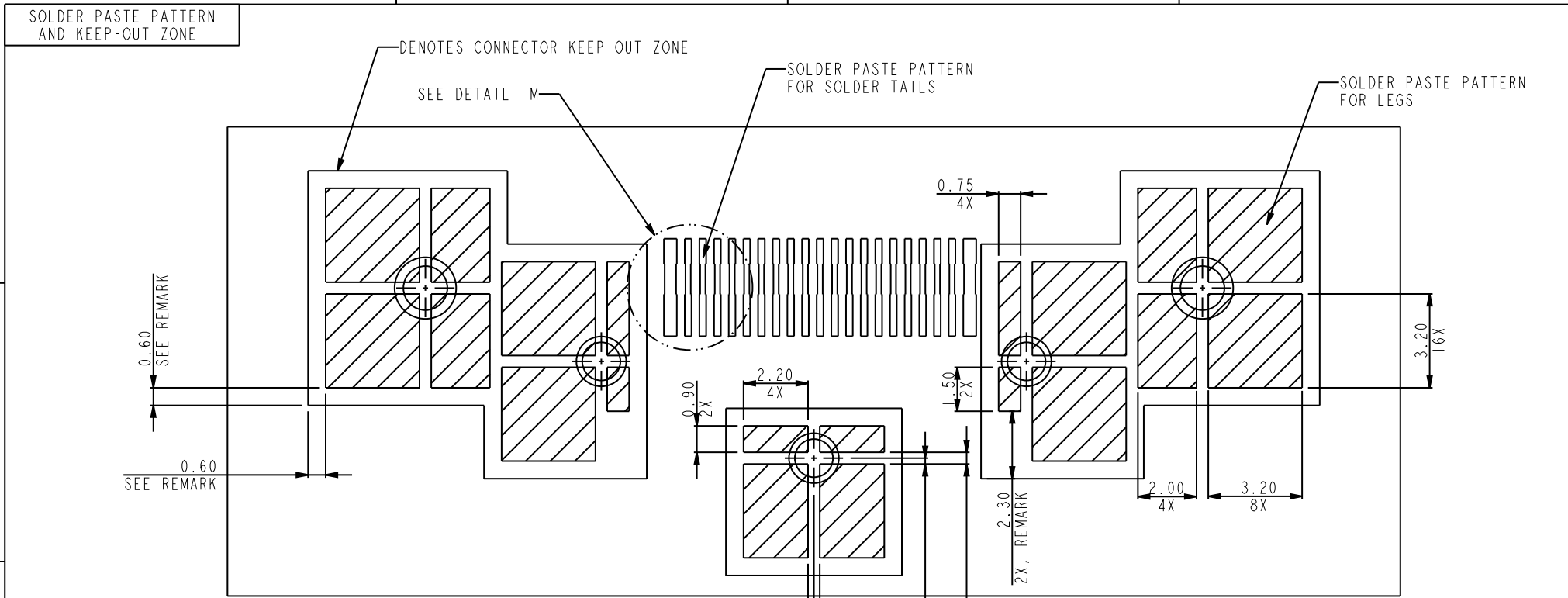

SOLDER PASTE PATTERN SCALE 5.000

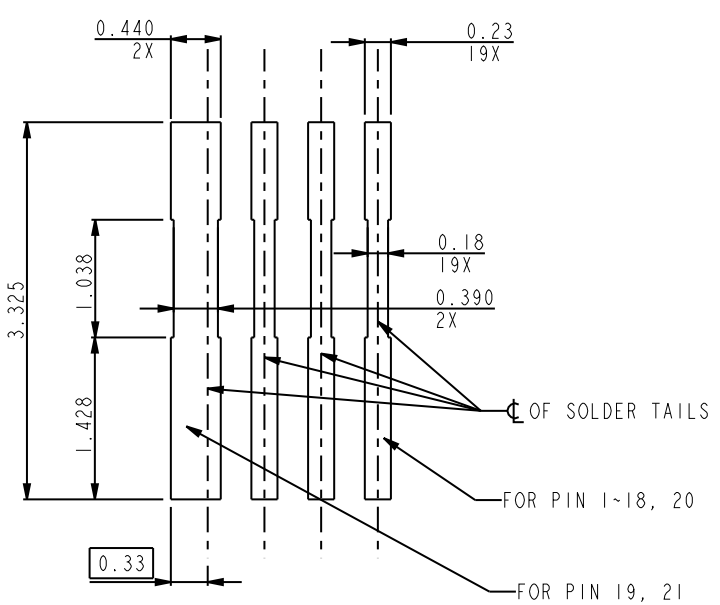

DETAIL M SOLDER PASTE SCALE 15.000

- REMARKS:
1. CONNECTOR KEEP OUT ZONE IS 0.60MM OFFSET FROM SOLDER PASTE BOUNDARY UNLESS OTHERWISE SPECIFIED.
 2. SOLDER PASTE THICKNESS IS 0.15MM NOMINAL.

www.fciconnect.com			surface	-	tolerance std	projection	MM	
			TOLERANCES UNLESS OTHERWISE SPECIFIED					
Dr	BEER FU	061107	ANGULAR	LINEAR	0.X	±0.30	A4	
Eng	BEER FU	061107			0.XX	±0.15		Scale
Chr	PAUL WANG	061107	0°	±2°	0.XXX	±0.08	ECN	N09-0142
Appr	JOSEPH HSIA	061107	Product family				Spec ref	*
FCI			title		ASSEMBLY		dwg no	10078837
					HDMI BOARD CONNECTOR, VERTICAL TYPE		Rev.	H
			catalog no		-		CUSTOMER	sheet 3 of 5

COPPER LAND AND SOLDER RESISTER OPENING

SOLDER RESISTER

A

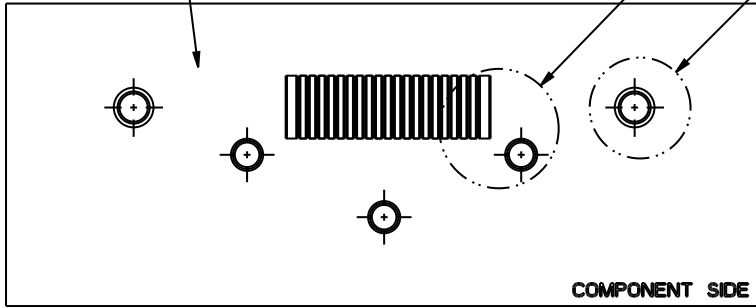

COMPONENT SIDE
SCALE 2.500

B

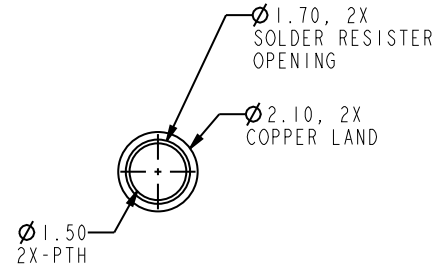

DETAIL U
SCALE 5.000

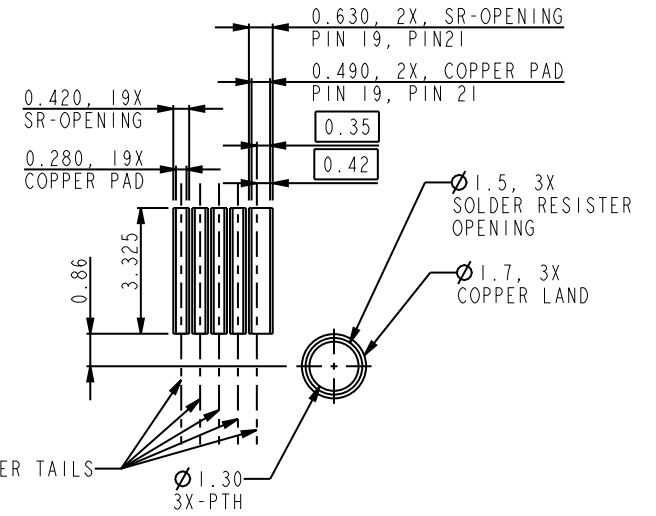

DETAIL V
SCALE 5.000

C

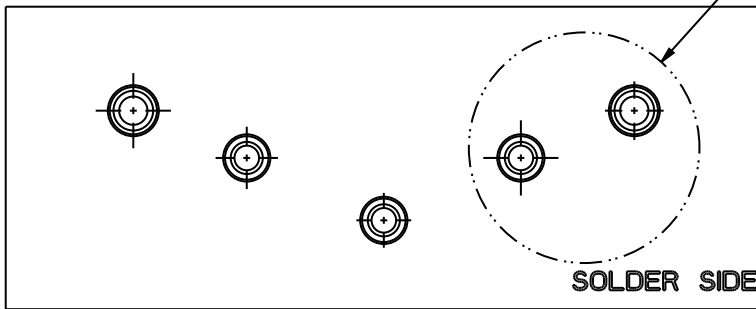

SOLDER SIDE
SCALE 2.500

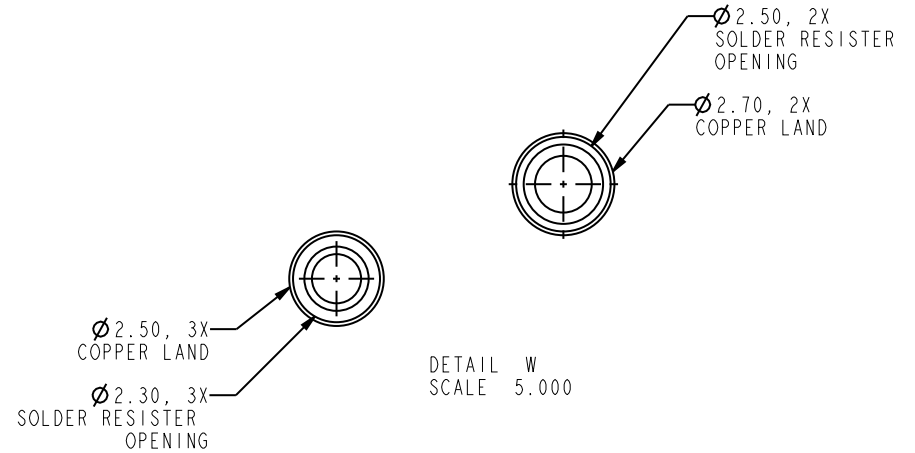

DETAIL W
SCALE 5.000

Copyright FCI.

D

www.fciconnect.com			surface	<input checked="" type="checkbox"/>	tolerance	std	projection	MM	
			TOLERANCES UNLESS OTHERWISE SPECIFIED						
Dr	BEER FU	061107	ANGULAR	LINEAR	0.X	±0.30	size	A4	
Eng	BEER FU	061107			0.XX	±0.15		Scale	1.000
Chr	PAUL WANG	061107			0°	±2°		0.XXX	±0.08
Appr	JOSEPH HSIA	061107	Product family			-	Spec ref		*
		title ASSEMBLY HDMI BOARD CONNECTOR, VERTICAL TYPE			dwg no 10078837		Rev. H		
catalog no -		CUSTOMER			sheet 4 of 5				

PIN ASSIGNMENT

CONNECTOR MATING SIDE	
PIN	SIGNAL ASSIGNMENT
1	TMDS Data2+
2	TMDS Data2 Shield
3	TMDS Data2-
4	TMDS Data1+
5	TMDS Data1 Shield
6	TMDS Data1-
7	TMDS Data0+
8	TMDS Data0 Shield
9	TMDS Data0-
10	TMDS Clock+
11	TMDS Clock Shield
12	TMDS Clock-
13	CEC
14	Reserved (N.C. on device)
15	SCL
16	SDA
17	DDC/CEC Ground
18	+5V Power
19	Hot Plug Detect

Remark:
There are 19 Pins in mating side,
HDMI type A cable is compatible.

CONNECTOR SOLDER TAILS	
PIN	SIGNAL ASSIGNMENT
1	TMDS Data2+
2	TMDS Data2 Shield
3	TMDS Data2-
4	TMDS Data1+
5	TMDS Data1 Shield
6	TMDS Data1-
7	TMDS Data0+
8	TMDS Data0 Shield
9	TMDS Data0-
10	TMDS Clock+
11	TMDS Clock Shield
12	TMDS Clock-
13	CEC
14	Reserved (N.C. on device)
15	SCL
16	SDA
17	DDC/CEC Ground
18	+5V Power
19	Hot Plug Detect
20	Ground to PCB
21	Ground to PCB

Remark:
Two extra pin 20, 21 are designed to
ground to board, enhance the EMI
performance in system level.

www.fciconnect.com			surface <input checked="" type="checkbox"/>	tolerance std	projection	MM		
			TOLERANCES UNLESS OTHERWISE SPECIFIED					
Dr	BEER FU	061107	ANGULAR	LINEAR	0.X	±0.30	size A4	Scale 1:000
Eng	BEER FU	061107			0.XX	±0.15		
Chr	PAUL WANG	061107			0° ±2°	0.XXX	±0.08	ECN
Appr	JOSEPH HSIA	061107	Product family		-	Spec ref *		
		ASSEMBLY			dwg no		10078837	Rev. H
		HDMI BOARD CONNECTOR, VERTICAL TYPE			CUSTOMER		sheet 5 of 5	
		catalog no						



Copyright FCI.