

THIS DRAWING IS UNPUBLISHED. RELEASED FOR PUBLICATION
 © COPYRIGHT BY TYCO ELECTRONICS CORPORATION. ALL RIGHTS RESERVED.

LOC		DIST		REVISIONS			
P	LTR	DESCRIPTION	DATE	DWN	APVD		
	E	UPDATE PROFILE OF SCREW (THREAD COLLAR)	1 DEC 10	MKS	-		

SIZE	A DIA	B DIA	T THREAD	JACKSCREW P/N	RET RING P/N
1.0mm	∅.060	∅.0655	1.00UNM (0.25mm PITCH)	1589283-3	1589284-1
1.2mm	∅.065	∅.0735	1.20UNM (0.25mm PITCH)	1589283-4	1589284-2

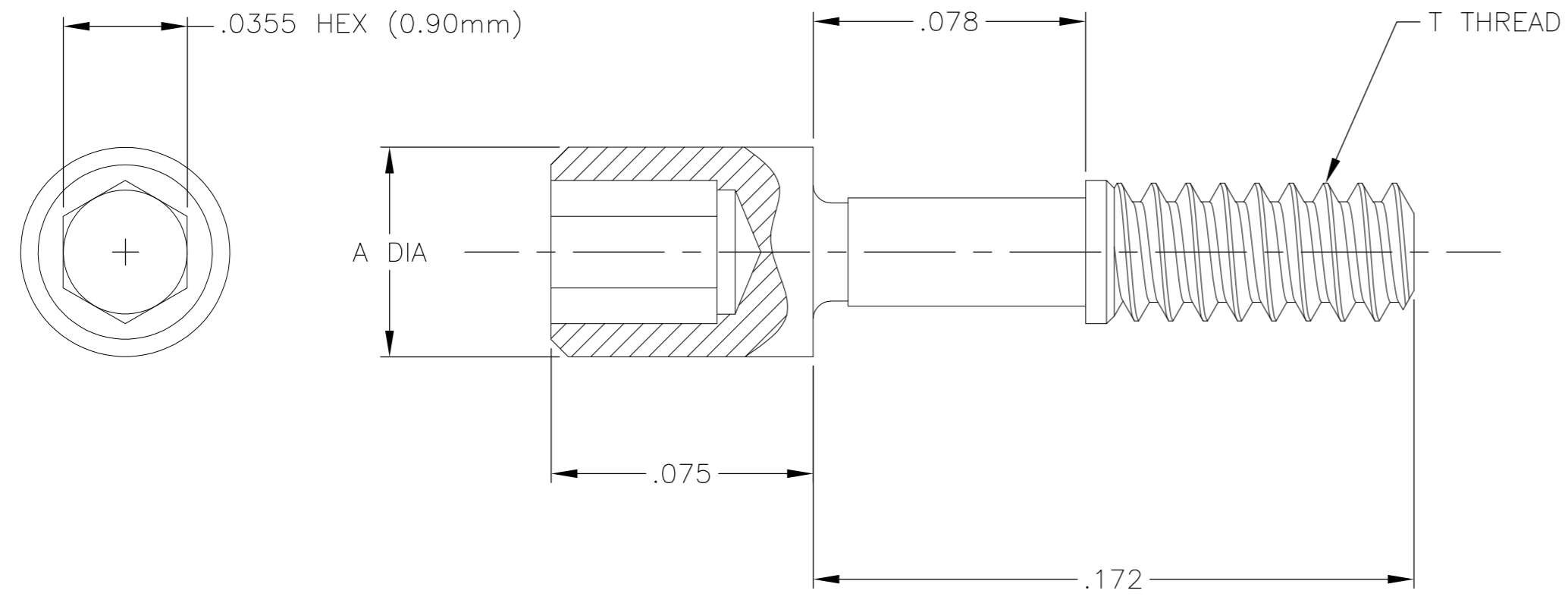

STANDARD JACKSCREW 1

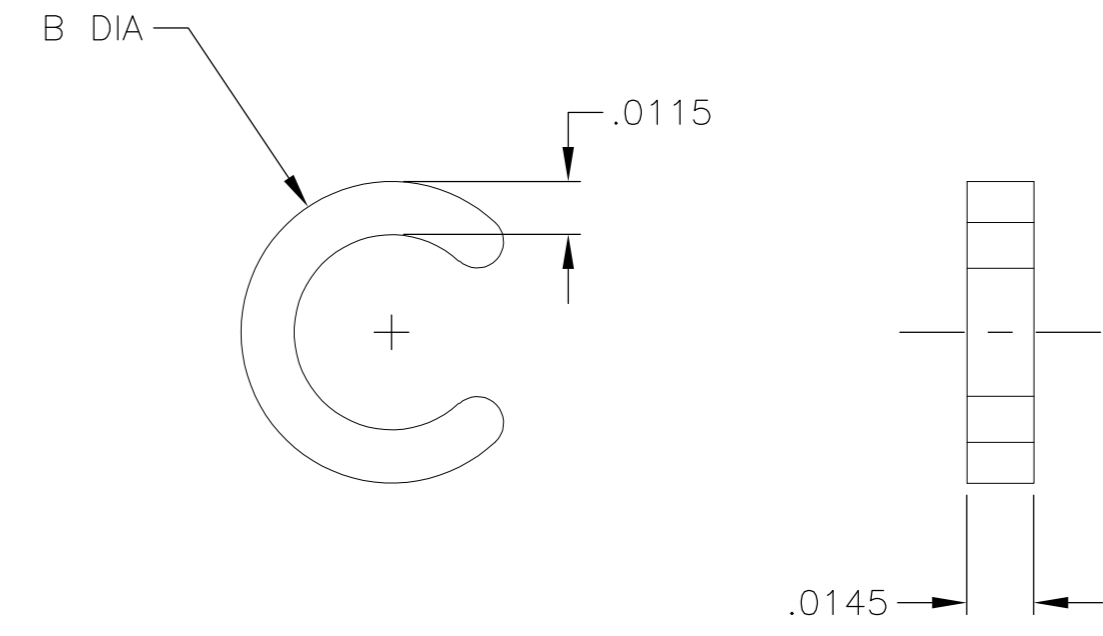

STANDARD RETAINING RING 2 3

- 1 JACKSCREW MATERIAL: 303 STAINLESS STEEL PER ASTM A581, CONDITION A, PASSIVATE PER SAE-AMS-2700, TYPE 2, DRY FILM LUBE PER DOD-L-85645 TYPE I
- 2 RETAINING RING MATERIAL: 17-4 STAINLESS STEEL PER ASTM A564, CONDITION A, PASSIVATE PER SAE-AMS-2700, TYPE 2
- 3 DIMENSIONS FOR RETAINING RING ARE PRIOR TO INSTALLATION ONTO THE JACKSCREW. RETAINING RING MUST BE CRIMPED AROUND THE SHAFT OF THE SCREW TO PROPERLY CAPTIVATE THE SCREW ONTO DUALLOBE PLUG CONNECTORS.

THIS DRAWING IS A CONTROLLED DOCUMENT.		DWN M STORRY 17 DEC 02	Tyco Electronics Corporation Harrisburg, PA 17105-3608	
DIMENSIONS: INCHES	TOLERANCES UNLESS OTHERWISE SPECIFIED:	CHK -	APVD M STORRY 1 DEC 10	NAME
	0 PLC ± -	PRODUCT SPEC		STANDARD NANONICS JACKSCREW AND RETAINING RING, 1.0mm AND 1.2mm SIZES
	1 PLC ± -	APPLICATION SPEC		SIZE CAGE CODE DRAWING NO RESTRICTED TO
MATERIAL SEE NOTES	FINISH SEE NOTES	WEIGHT -	A2 0PJN9 C=303-0076	SCALE 24:1 SHEET 1 OF 1 REV E
		CUSTOMER DRAWING		

303-0076