

COAXIAL ATTENUATOR SMA 2.9 DC-40GHZ

R413.310.000

2 W - 10DB

Series : ATTENUATOR

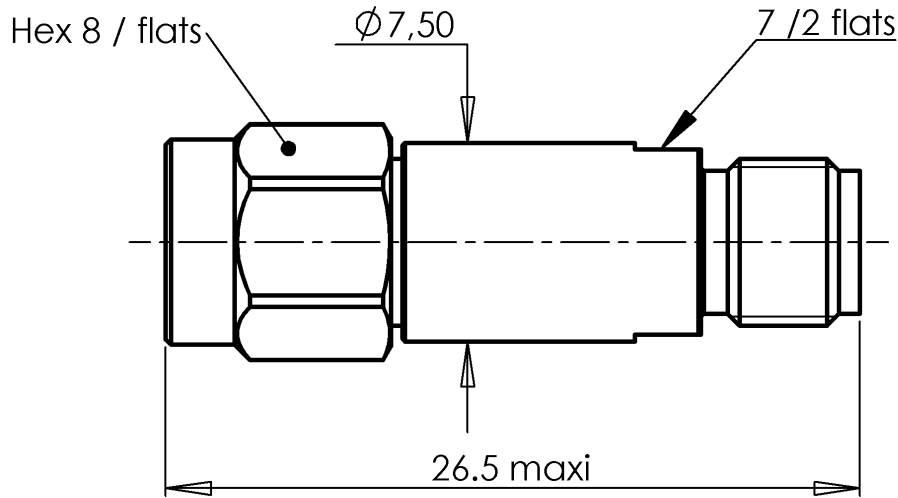

Scale 1:1

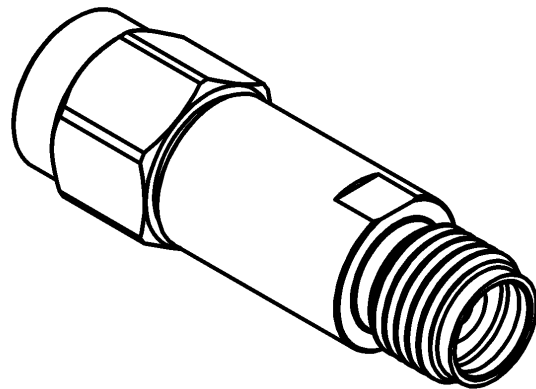

All dimensions are in mm.

COMPONENTS	MATERIALS	PLATING(μm)
BODY	STAINLESS STEEL	PASSIVATION
MALE CENTER CONTACT	BERYLLIUM COPPER	.GOLD 1.3 OVER NICKEL 2
FEMALE CENTER CONTACT	BERYLLIUM COPPER	.GOLD 1.3 OVER NICKEL 2
OUTER CONTACT	STAINLESS STEEL	PASSIVATION
INSULATOR	-	-
GASKET	SILICONE RUBBER	-
SUBSTRATE	CERAMIQUE D'ALUMINE	-
RESISTOR	-	-
OTHERS PARTS	-	-

Issue : 0741 C

In the effort to improve our products, we reserve the right to make changes judged to be necessary.

COAXIAL ATTENUATOR SMA 2.9 DC-40GHZ

R413.310.000

2 W - 10DB

Series : ATTENUATOR

ELECTRICAL CHARACTERISTICS

Frequency (GHz)	40
V.S.W.R (≤)	1.60 (1.4 typ.)
Deviation(±dB)	0.8

Operating Frequency Range	DC - 40	GHz
Impedance	50	Ω
Nominal Attenuation	10	dB
Peak power at 25°C (1μs, 1%)	100	W
Average power at 25°C	2	W (Free Air Cooled)

MECHANICAL CHARACTERISTICS

Connectors	SMA 2.9	Male Female	MIL-C 39012
Weight	6,5700	g	

ENVIRONMENTAL CHARACTERISTICS

Operating temperature range	-55/+125 °C
Storage temperature range	-55/+125 °C

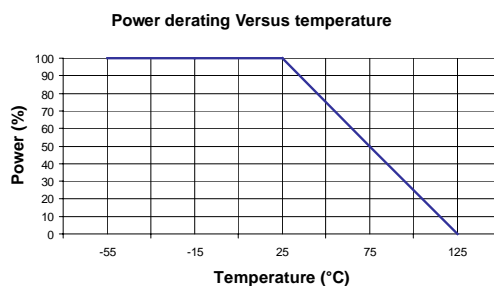

SPECIFICATION

OTHER CHARACTERISTICS

Temperature sensitivity : $4 * 10^{-4} \frac{dB}{dB * ^\circ C}$

Issue : 0741 C

In the effort to improve our products, we reserve the right to make changes judged to be necessary.