

Bourns®

Circuit Protection Selection Guide



Circuit Protection Solutions

The Bourns Mission

Our goal is to satisfy customers on a global basis while achieving sound growth with technological products of innovative design, superior quality and exceptional value. We commit ourselves to excellence, to the continuous improvement of our people, technologies, systems, products and services, to industry leadership and to the highest level of integrity.

Table of Contents

Introduction	2
Why Protection is Needed	3
Bourns® Circuit Protection Products	5
Select the Appropriate Device for your Application	8
Network Diagram	8
Generic Circuit Diagrams	10
Central Office (CO)	10
Customer Premises (CPE)	12
DSL and Voice Protection	13
ADSL Splitter with Primary	14
T1/E1 Application	14
ESD	15
New Technology Applications	16
USB OTG	16
Power over Ethernet	16
Product Selection Tables	17
Telecom Line Protection	17
Customer Premises Equipment	18
ESD Protection	20
Overvoltage Protection Components	
GDT – Gas Discharge Tubes	21
TSP – Thyristor Surge Protectors	27
TVS Diodes – Transient Voltage Suppressor Diodes	45
Overcurrent Protection Components	
Multifuse® – Polymer PTCS	49
LPMs - Line Protection Modules	58
Telefuse™ – Telecom Fuses	60
ESD Protection Components	
ESD Protection Overview	61
ChipGuard® – Multilayer Varistors	62
Diode Arrays for ESD protection	64
Outside Plant	
Outside Plant Products	66
Signaling Protectors	68
Other Related Products and Capabilities	
Transformers	70
Module Solution Capability	74
DC-DC Converters	76
Which Protection Technology is Right for the Equipment	78
Telecommunications Standards and Recommendation Summary	92

Introduction

Bourns is pleased to present this comprehensive guide to Telecom Circuit Protection, encompassing our broad range of technologies and products. This guide will provide the background information and selection recommendations needed to ensure that your next project achieves the level of cost-effective field reliability demanded by today's customers.

Bourns commissioned a survey of telecom circuit protection users worldwide to determine their priorities and needs. We found that reliability, technical and design support and exemplary knowledge of protection technology were by far the three most cited items. Bourns is committed to meeting each of the three following requirements.

Reliability – Reliability requires an understanding of the capabilities and specifications of circuit protection technology. Bourns has a global reputation for quality products and our circuit protection devices have consistently demonstrated reliability in field applications. Bourns is committed to the complete support of a circuit protection solution for the life of a program.

Technical and Design Support – Bourns has a global team of specialized sales and Field Applications Engineers (FAEs) ready to bring in-depth circuit protection expertise to your next project. Wherever you are located in the world you have a regional applications team available to help you from Asia and Europe to the Americas. For your next application why not contact your local sales office which will put you in contact with your nearest FAE to help you to make the right choice of circuit protection solutions for your application.

Knowledge of Protection Technology – Bourns boasts the industry's widest range of telecom overvoltage and overcurrent protectors. Our active involvement in international protection standards organizations ensures world-class technology and applications expertise. Bourns continues to develop an innovative range of integrated circuit protection products using our knowledge and expertise to combine multiple technologies into optimized single devices designed to save both cost and board space. Whether you need a single product or a complete protection solution, Bourns telecom circuit protection team is there to help you. We look forward to working with you.

The Bourns Website – Bourns website, www.bourns.com, is an invaluable resource to further help you determine your circuit protection solution. The following information is available:

- Comprehensive data sheets
- A product selection tool
- Reference Design Notes (<http://www.bourns.com/archive.aspx>)
- Tutorials in the area of circuit protection (<http://www.bourns.com/archive.aspx>)
- More detailed information on regulatory requirements

Why Protection Is Needed

Communication systems are vulnerable to damage from lightning or other electrical surges. As systems become more complex, they also become more vulnerable. Balancing the cost, standards compliance and field reliability of protection of such systems is both a commercial and technical challenge, compounded by the additional performance constraints of modern digital networks such as xDSL.

A “surge” is a temporary increase in voltage, current or both. Lightning and the AC power distribution system cause surges, but of very different magnitudes and durations (see Table 1). These events can either be via direct contact or by field or resistive coupling from events close to the telephone system, resulting in a wide variety of threats. For example, the effects of a power line fault caused by lightning may even be more threatening to the telephone system than the original lightning. The dangers of large voltages and currents are obvious, but time is also important. Lightning is too fast for bulk heating to be critical, whereas for the longer term currents of AC power faults, bulk heating can significantly effect device survival and safety. Direct contact to the AC (power cross) causes high currents, while lower currents result from power induction. Obviously, a single device protection solution is seldom possible.

	Amplitude	Duration	Bulk Heating
Lightning	kA, kV	μs	Negligible
Power Cross	60 A	<30 mins	Significant
Power Induction	7 A	<30 mins	Crucial

Table 1. Different surge sources result in very different effects

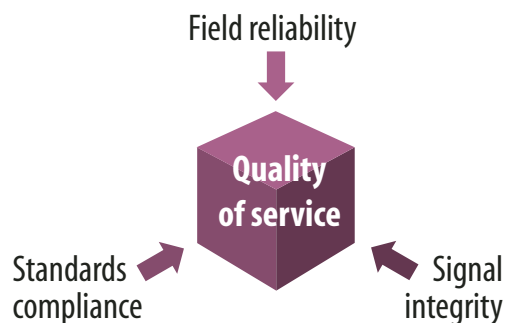
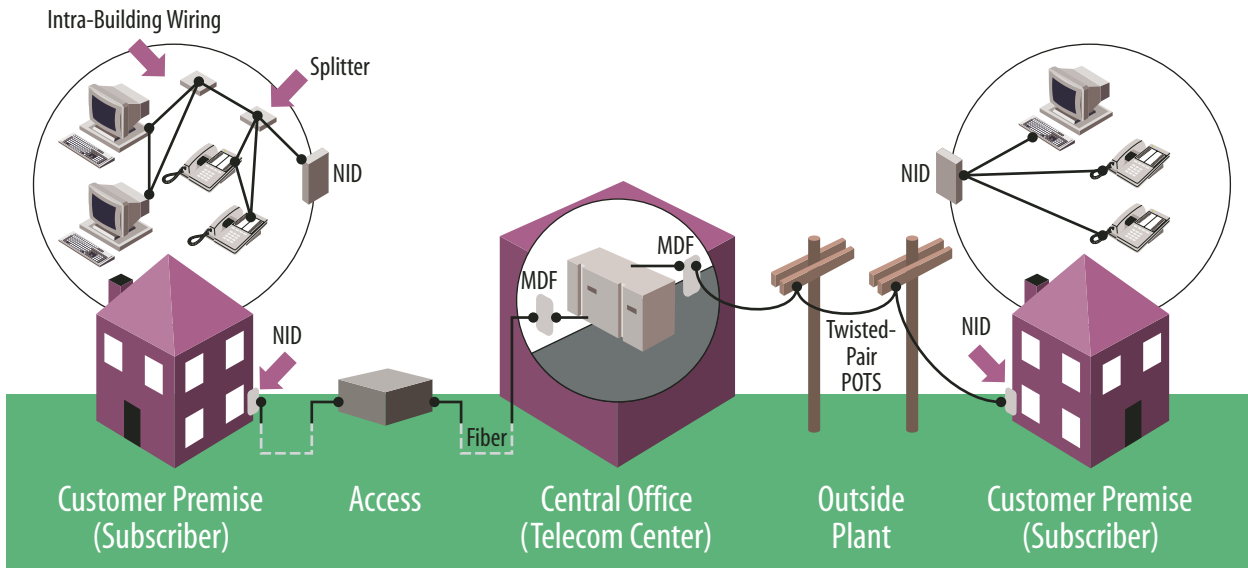

Figure 1. Protecting “Quality of Service” requires more than standards compliance

Protection performs several key functions as outlined in Figure 1. First it must prevent or minimize damage caused by a surge; then it must ensure that the system returns to a working condition with minimal disruption to service. It is vital that under normal conditions the protection does not interfere with the signal, creating special challenges for xDSL and other digital technologies. The protection must also fail in a safe manner during overstress.

Development of Standards – Due to the enormous cost of interrupted service and failed network equipment, telephony service providers around the world have adopted various specifications to help regulate the reliability and performance of the telecommunications products that they purchase. In Europe and much of the Far East, the most common standards are ITU-T K.20, K.21 and K.45. In North America, most operating companies base their requirements on GR-1089-CORE, TIA-968-A (formerly known as FCC Part 68), and UL 60950.

The Telecommunication Standards and Recommendations Summary discusses these various standards in more depth. Figure 2 on the next page summarizes the applicable standards.



Circuit Protection		Customer Premise		Access		Central Office	
US Region	Powered IT Safety	UL 60950-1 (2003)				UL 60950-21 (2003)	
	Primary Protection			GR-974-CORE 2002 GR-1361-CORE (1998)			
	Equipment Secondary Protection	TIA-968-A + A1 + A2 (2002-2003-2004 – Part 68) GR-1089-CORE (2002)		GR-1089-CORE (2002)		GR-1089-CORE (2002)	
Int'l	Powered IT Safety	IEC 60950-1 (2001)	IEC 60950-21 (2002)	ITU-T K.50 (2000)	ITU-T K.51 (2000)		
	Primary Protection			ITU-T K.12 (2000) ITU-T K.28 (1993)			
	Equipment Secondary Protection	ITU-T K.21/44 (2003)		ITU-T K.45/44 (2003)		ITU-T K.20/44 (2003)	

Figure 2

Bourns® Circuit Protection Products

Overvoltage Products

Bourns family of **Gas Discharge Tubes (GDTs)** creates a quasi short circuit across the line when the gas is ionized quasi by an overvoltage, returning to their high impedance state after the surge has terminated. These robust devices have the highest impulse current capability of any technology combined with negligible capacitance, making them very attractive for the protection of high speed digital lines as well as standard POTS lines.



MSP® and TRIGARD® Gas Discharge Tubes

Bourns family of **TISP® Thyristor**-based devices initially clamp the line voltage, and then switch to a low-voltage “On” state. After the surge, when the current drops below the “holding current,” the protector returns to its original high impedance state.



TISP® – Telecom Overvoltage Protectors

Bourns offers a family of **Transient Voltage Suppressor (TVS) Diodes** which operate by rapidly moving from high impedance to a non-linear resistance characteristic that clamps surge voltages. TVS diodes provide a fast-acting and well-controlled clamping voltage, however they exhibit high capacitance and low energy capability thereby restricting the maximum surge current.



TVS Diodes for low energy surge and ESD protection

Overcurrent Products

Bourns family of **Multifuse® Polymer Positive Temperature Coefficient (PPTC) Thermistor** “resettable fuses” is used in a wide variety of circuit protection applications. Under high current fault conditions the device resistance will increase by many orders of magnitude and remain in a “tripped” state, providing continuous circuit protection until the fault is removed. Once the fault is removed and the power cycled, the device will return to its normal low resistance state.



Multifuse® Resettable Fuses

Bourns family of **Telefuse™ Telecom Fuses** is constructed from a metal element encapsulated in a ceramic housing. The fuse element heats up at the rate of I^2R . Once the temperature of the element exceeds the melting point, it vaporizes and opens the circuit. The low resistance of fuses is attractive for xDSL applications.



Telefuse™ Telecom Fuses

Bourns family of **Line Protection Modules (LPMs)** is based on the most fundamental form of current protection, the **Line Feed Resistor (LFR)**, normally fabricated as a thick-film resistor on a ceramic substrate. LPMs have the ability to withstand high voltage impulses without breaking down, AC current interruption occurs when the high temperature developed by the resistor causes mechanical expansion stresses that result in the ceramic breaking open. Low current power induction may not break the LFR open, creating long-term surface temperatures of more than 300 °C. To avoid heat damage to the PCB and adjacent components, maximum surface temperature can be limited to about 250 °C by incorporating a series thermal fuse link on the LFR.



Line Protection Modules

This capability is extended to the design and manufacture of a full range of modules, incorporating both overcurrent and overvoltage devices on one ceramic substrate. Further incorporation of silicon die and discrete components is also possible to achieve small modules with high performance and full functionality.

ESD PROTECTION PRODUCTS

Bourns family of **ChipGuard® ESD clamp protectors** consists of multilayer varistors (MLV) designed to protect equipment against electrostatic discharge (ESD) conditions. The Bourns® ChipGuard® series has low leakage currents that make the devices transparent under normal operation. ESD transients cause the device to clamp the voltage by reducing its effective resistance and the device will reset to a high impedance state after the disturbance has passed. The Bourns® ChipGuard® product family is designed to protect equipment such as communication ports to IEC61000-4-2, level 4.



ChipGuard® Multilayer Varistors for ESD protection

Bourns offers a family of **Diode Arrays** for ESD protection. Using Thin Film on Silicon wafer fabrication technology combined with Chip Scale Packaging, such devices are commonly used in portable electronics applications where the customer has specified a particular electrical response characteristic for a minimum real estate allowance. Handheld wireless devices, in particular, cell phones and PDAs often have data and/or audio ports that



Diode Arrays for ESD protection (CSP options)

connect the device to other external devices such as laptop computers and headsets. Bourns offers the capability to integrate resistors, capacitors, inductors, diodes and transistors into a single monolithic device with minimal packaging overhead.

Outside Plant

Bourns **Outside Plant** product line offers a full line of protection products based on our own Gas Discharge Tube (GDT) and patented Multi-Stage Protection (MSP®) technology. Products include 5-Pin protectors for the central office, building entrances and a wide range of station protectors for the customer premises. We also offer a complete line of fully modular Network Interface Devices (NIDs) available from one to one hundred lines. Our NIDs are flexible with a wide variety of customizations available. Additionally, we round out our offering with a full line of ADSL and VDSL splitters available in both binding post and snap-in packages. All of our products are UL listed and manufactured to RUS and Telcordia technical requirements.

Bourns® **Data and Signal Systems Surge Protectors** offer surge protection to field mounted 4-20 mA transmitters. They feature a 1669 series protector with a sealed stainless steel pipe for easy connection to a field transmitter 1/2 inch NPT port and typically a rail-mounted 1820 series protector to protect the DCS equipment at the opposite end of the loop.

Other Products

Bourns offers a family of **Transformers** suitable for use in Telecom, LAN, Ethernet and xDSL applications. They exhibit high isolation and are ideal for signal conditioning, impedance matching and noise filtering applications. Devices are available for all leading chipsets.

A comparison of technologies used in telecom applications is described in the section entitled, “Which Protection Technology is Right for the Equipment,” including technologies not offered by Bourns, describing the general advantages and disadvantages of each and also giving suggestions for appropriate applications.



Outside Plant – NID Boxes and Data Line Protectors



Station Protectors – Central office / customer premises protectors

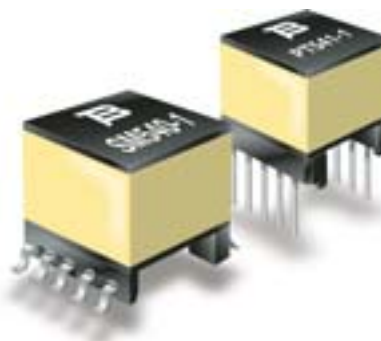

Custom Telecom Transformers





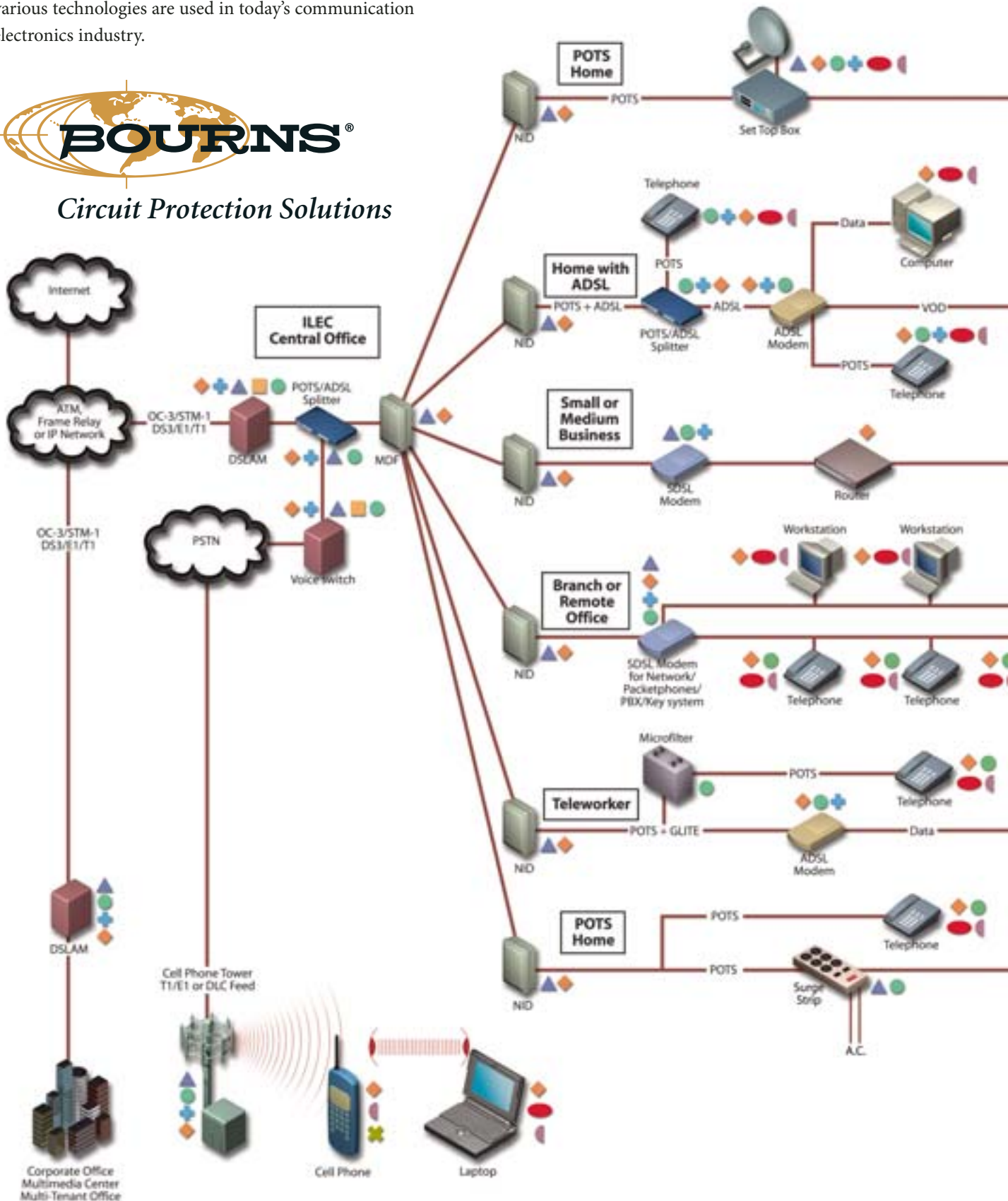

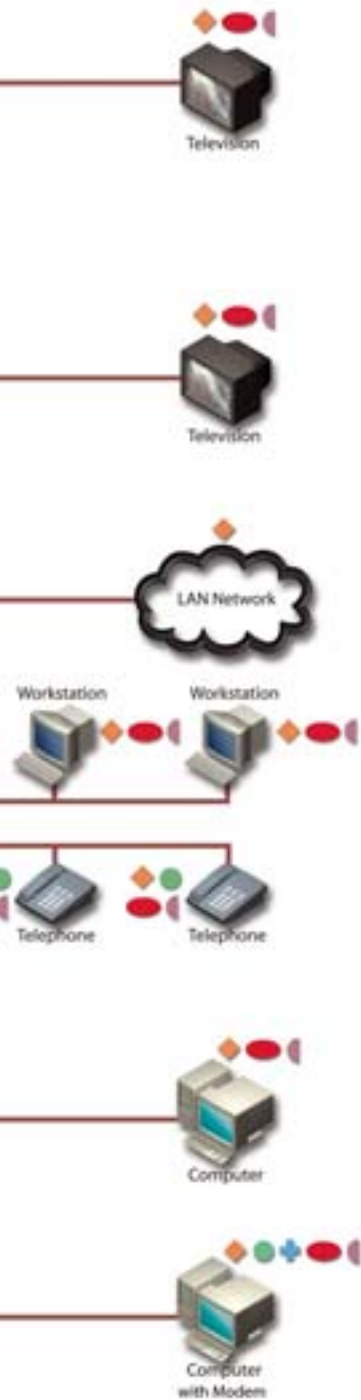

Selecting the Appropriate Device for your Application

The following Network Diagram gives an overview of where the various technologies are used in today's communication electronics industry.



Network Diagram



-  **GDT**
Gas Discharge Tubes
-  **TVS**
TVS Diodes
-  **LPM**
Line Protection Modules
-  **ChipGuard®**
Multilayer Varistors
-  **Telefuse™**
Telecom Fuses
-  **Diode Arrays**
ESD Protection
-  **Multifuse®**
Resettable Fuses
-  **TISP®**
Thyristor Surge Protectors

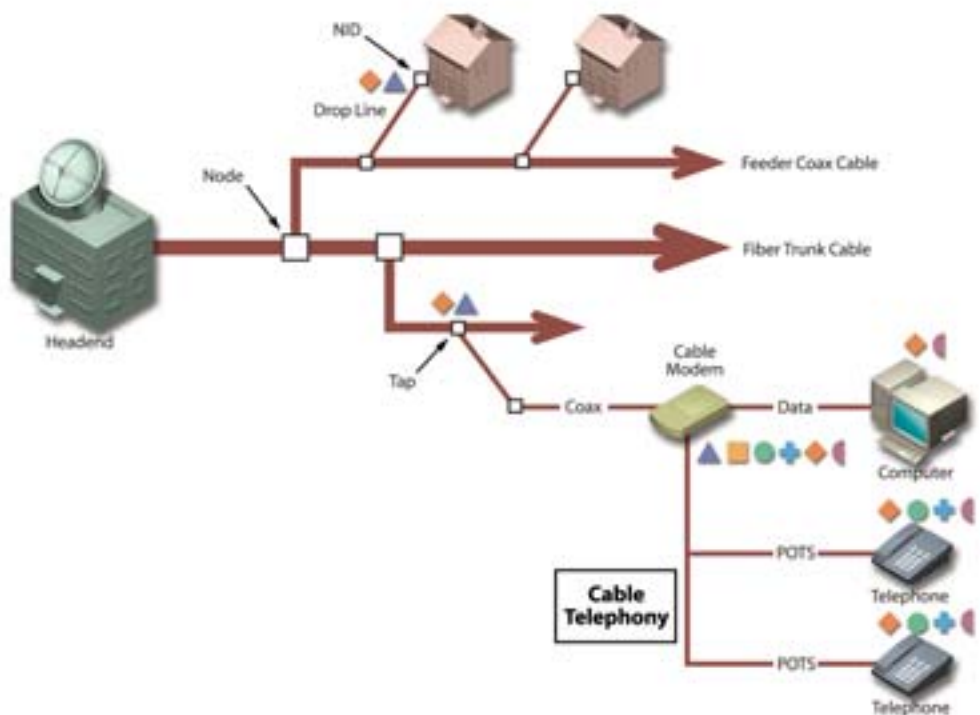

Several generic examples of the use of protection components are given over the following pages for your reference. Our field application engineers are available to discuss your actual circuit configuration and requirements.

Central Office (CO)

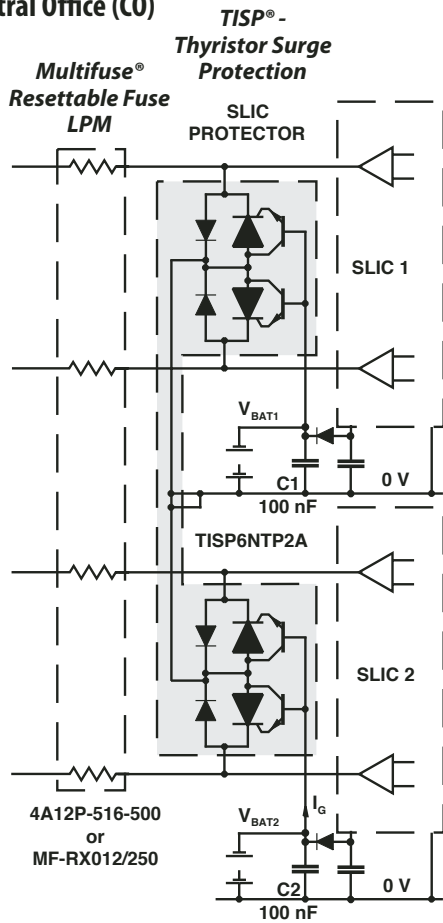

Integrated Line Protection for Multiple SLICs

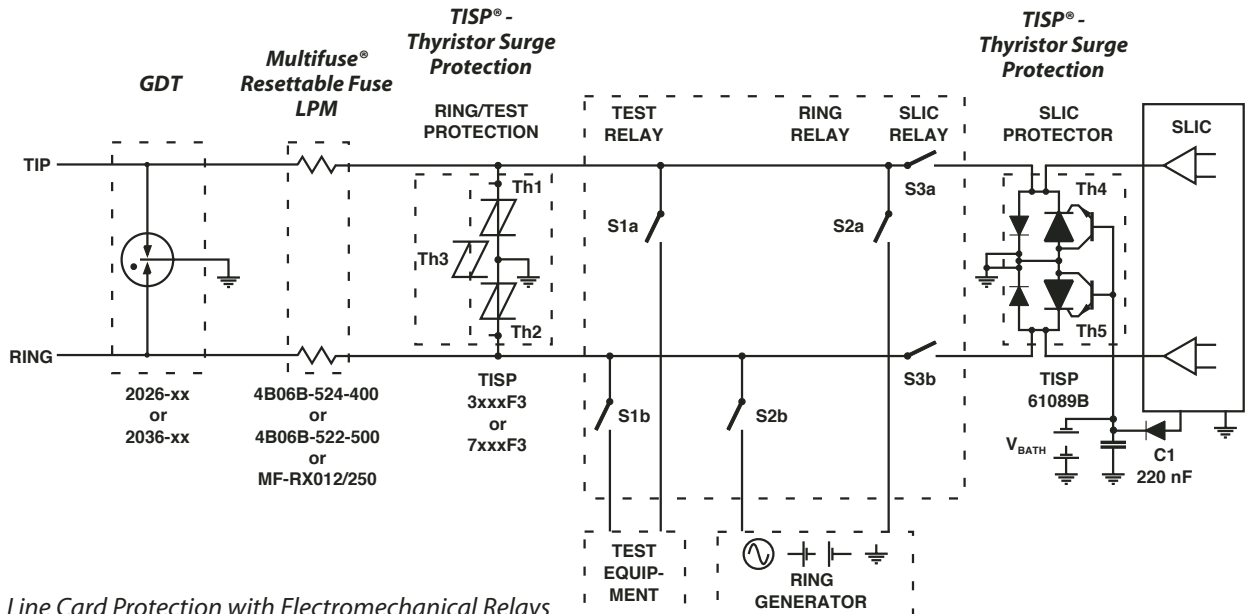

Line Card Protection with Electromechanical Relays

Central Office (CO) – continued

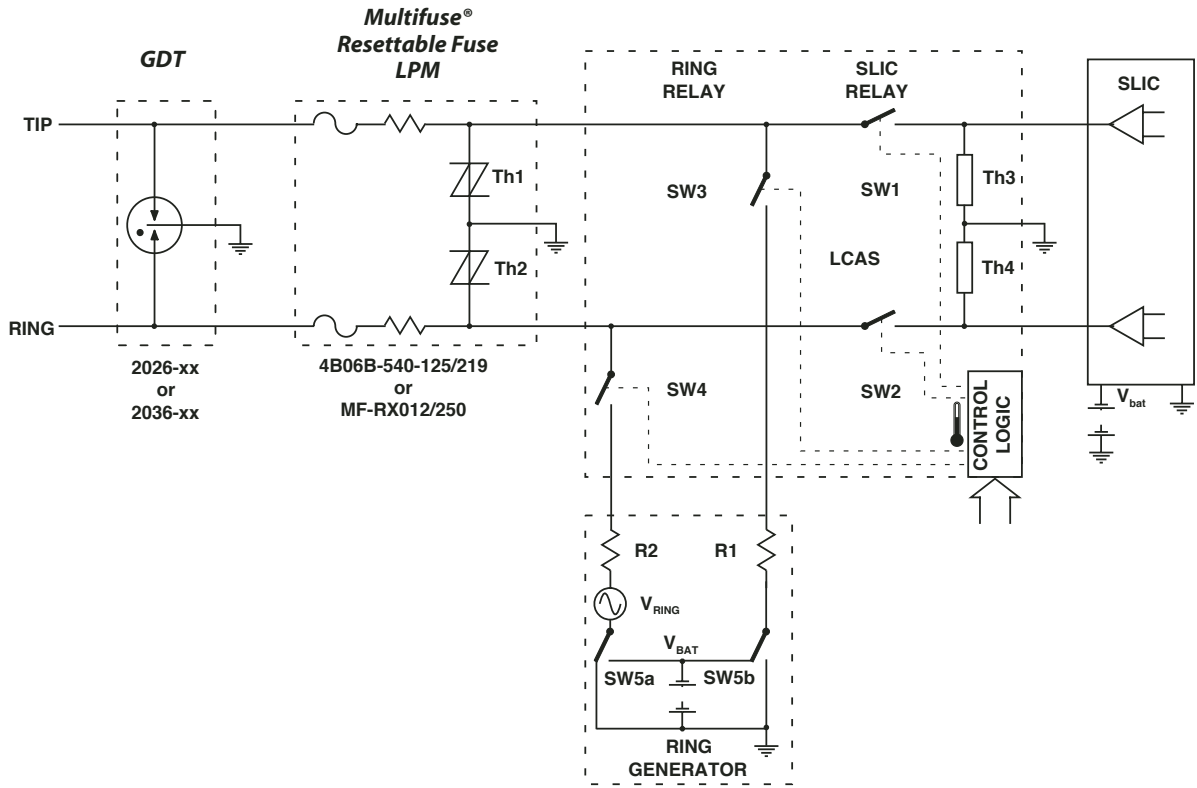

Line Card Protection with Solid-State Line Card Access Switch

Customer Premises (CPE)

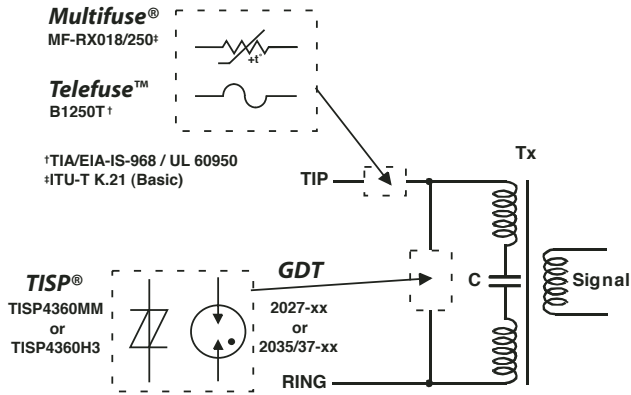

Basic ADSL Interface

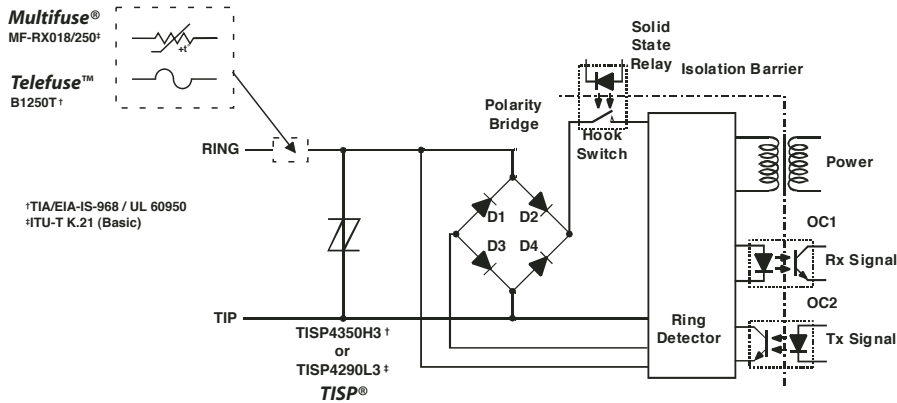

Basic Electronic Hook Switch Protection

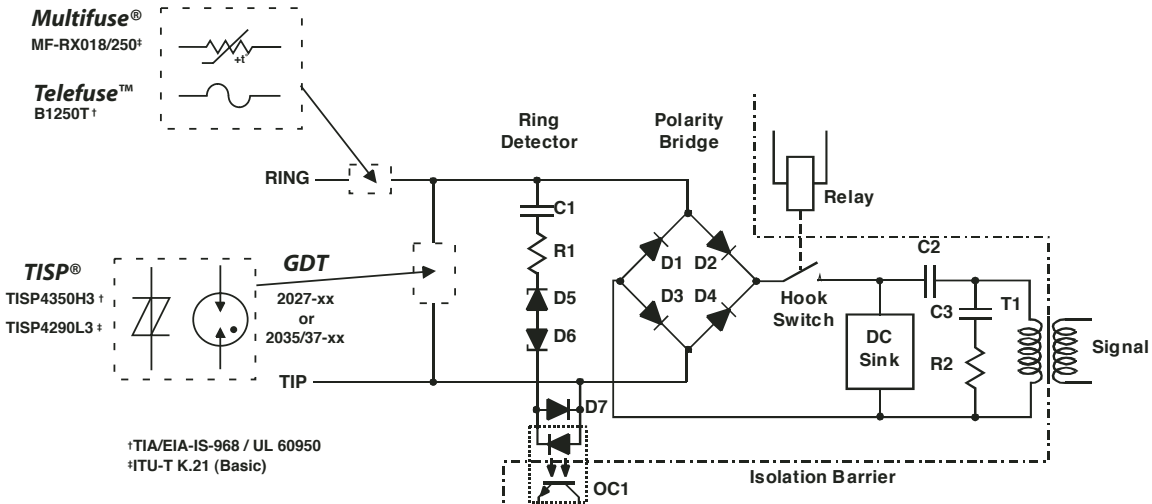

Basic Electromechanical Hook Switch Protection

DSL and Voice Protection

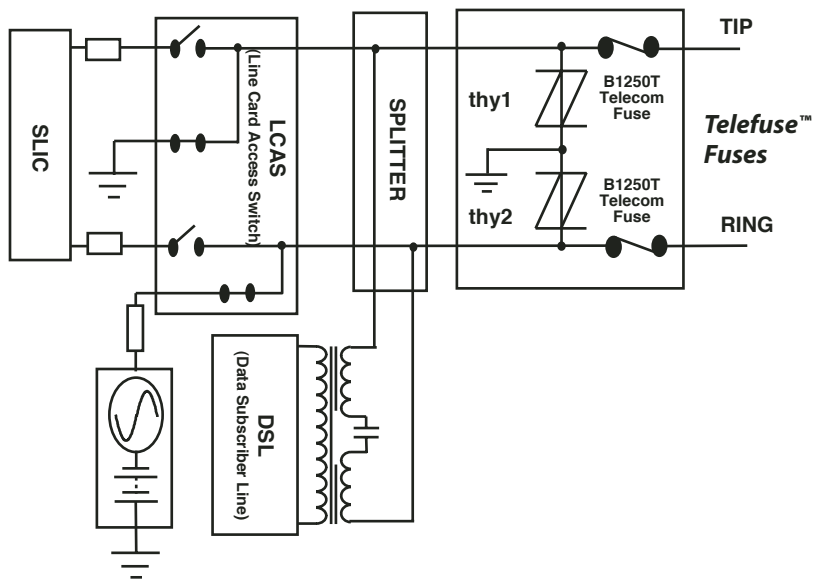
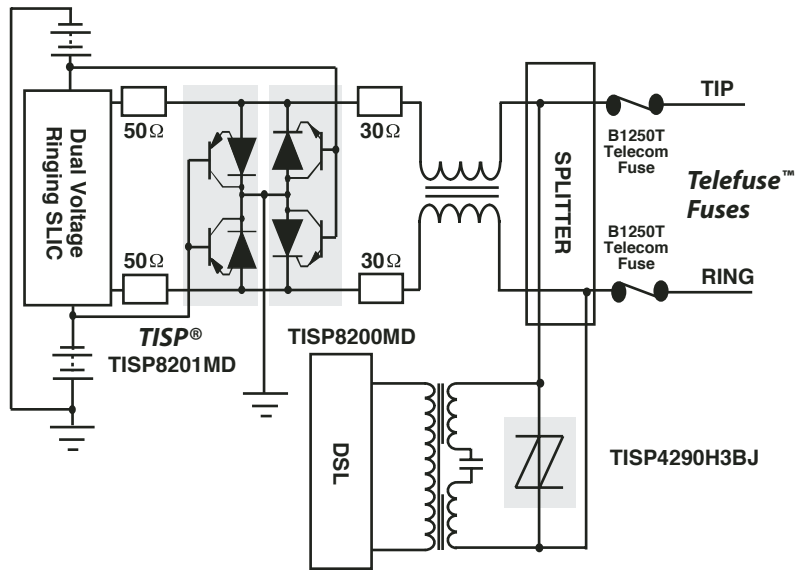
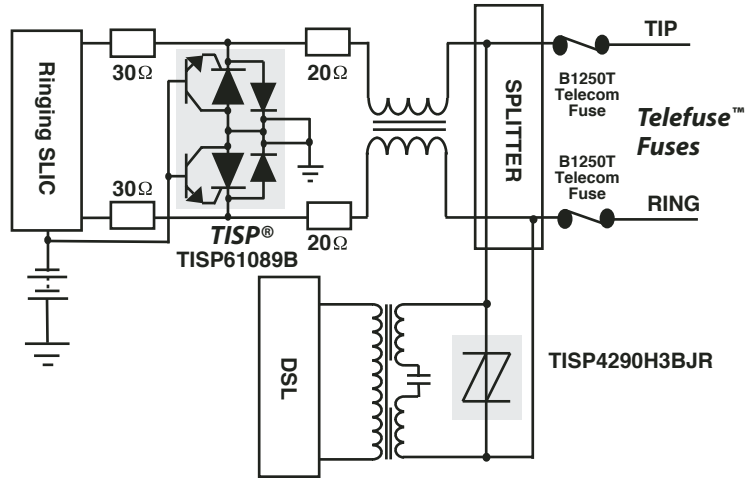

ADSL Splitter with Primary

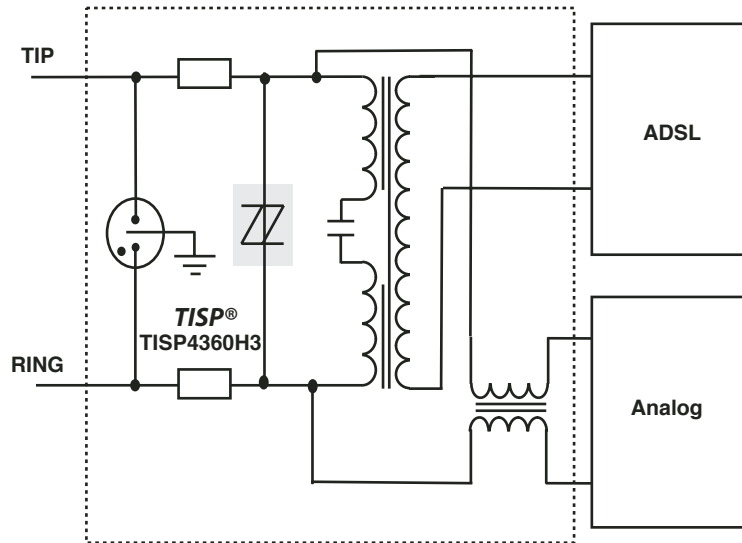

T1/E1 Application

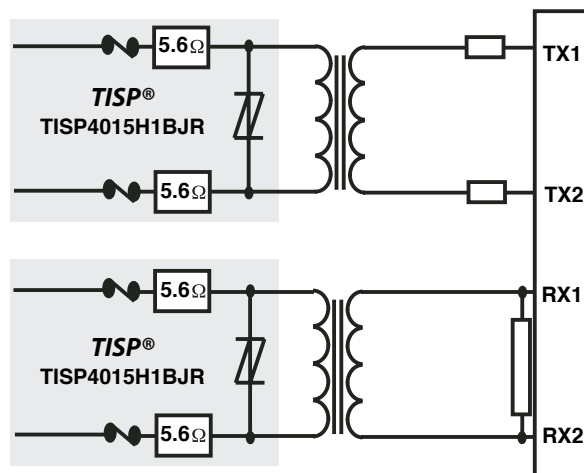
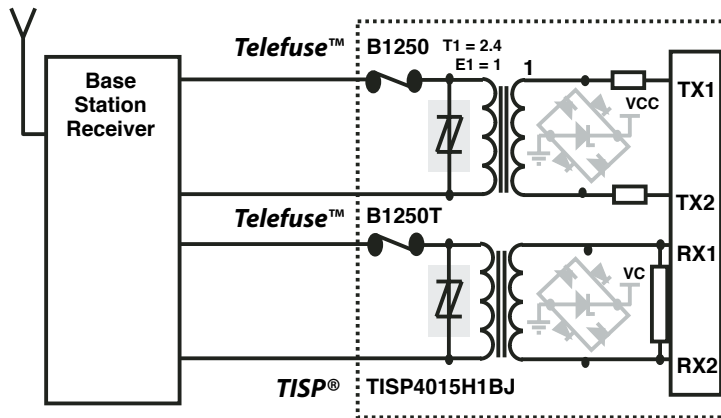

ESD Protection

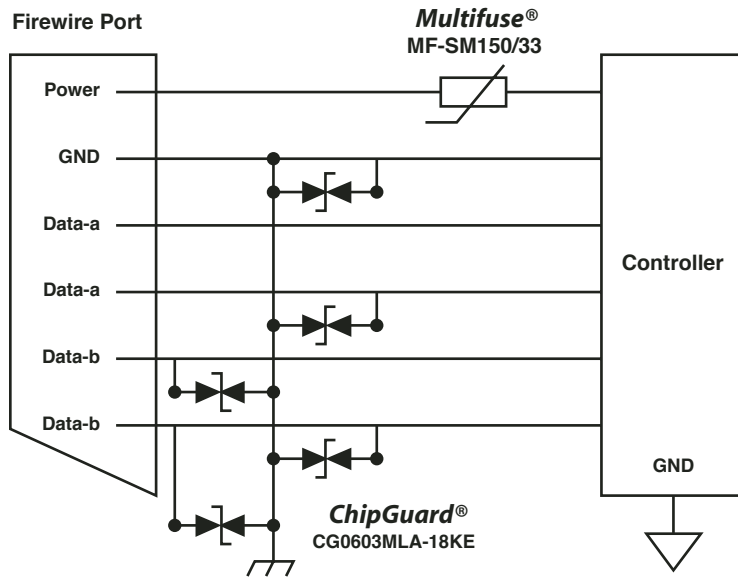
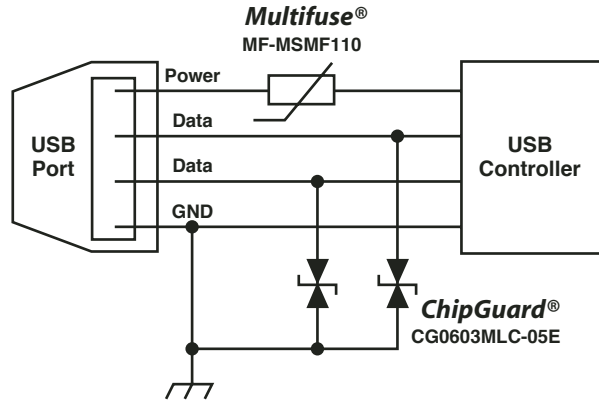

Communication Port Protection

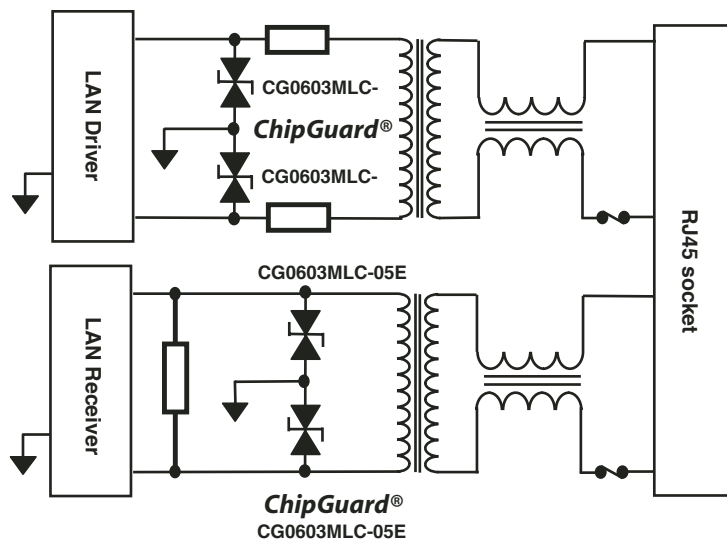

10/100 Base Ethernet Protection

New Technology Applications

USB On The Go (OTG)

After the success of the USB 2.0 standard, the USB Implementers Forum, Inc. developed an expansion standard called USB OTG (On The Go). USB OTG was developed based on the concept of allowing peripheral devices to communicate directly with each other without going through a PC host. USB 2.0 traditionally consisted of a host/periphery topology where a PC was the host and the peripheral could communicate only through the host device. However, USB OTG was introduced to supplement USB 2.0 to allow existing mobile devices to communicate in a point-to-point manner without the traditional host (PC).

Under USB OTG any peripheral device that is designed to act as a limited host (A-Device) must be able to transmit and receive power. In such equipment, if the current rating per port of the A-device is greater than 100 mA, then the voltage regulation is required to be between 4.75 V and 5.25 V, and the A-device is required to meet the USB 2.0 specification requirements for power providers. USB 2.0 makes overcurrent protection a requirement and a polymer PTC resettable fuse, such as a Bourns® Multifuse® polymer PTC resettable fuse, is a solution for providing such overcurrent protection. The Bourns® Multifuse® MF-MSMF Series and MF-NSMF Series have been introduced specifically for overcurrent protection of USB OTG ports.

Power over Ethernet (PoE)

The IEEE 803.3af Ethernet specification standard defines the voltage and current requirements of powered Ethernet equipment delivering up to 48 volts of DC power to PoE-compliant devices over eight-wire Category 5 and 6 cabling. There are two types of architecture. One is called mid-span, which involves running power over unused wire pairs in a LAN cable. Mid-span products are built into patch panel-like devices that can add PoE to existing LAN infrastructures. The other, an increasingly popular version of 802.3af is called end-span. End-span runs DC power signals over the same wire pairs used for data transmission. Industry experts say end-span devices are becoming popular because they are usually built into new switches with PoE, which users often buy for IP telephony or WLAN rollouts.

Typically, designers chose to back up the power management circuit with a solid state polymer PTC resettable fuse. The resettable fuse deactivates any port not protected by the power management circuit due to a temporary or permanent fault and thereby prevents further system failures.

The Bourns® device is a compact, symmetrical 2018 footprint design with a very low profile. The design facilitates incorporation onto the already densely populated boards of today's network equipment.

Product Selection Tables

It is important to read the Technology Comparison section of this guide prior to deciding what device is right for the application. We strongly advise that you contact your local Bourns Field Applications Engineer to discuss your exact application and choice of device(s). The advantages and disadvantages of each technology is discussed which will further help in the correct choice of components and/or modules.

Telecom Line Protection

Central Office & Access Equipment

Application/Function	Protected Element	U.S.A.		International			
		Central Office / Access GR-1089-CORE		Central Office ITU-T K.20 & K.44		Access ITU-T K.44 & K.45	
		Overvoltage Protection	Overcurrent Protection	Overvoltage Protection	Overcurrent Protection	Overvoltage Protection	Overcurrent Protection
xDSL Line Card	DSLAM Capacitor	2X TISP4xxxH3BJ + TISP4xxxJ1BJ 2X TISP4xxxH3BJ 2035-35-SM	B1250T	2X TISP4xxxL/M3 + TISP4xxxH3 2X TISP4xxxL/M3	MF-RX018/250 B1250T	2X TISP4xxxL/M3 + TISP4xxxH3 2X TISP4xxxL/M3	MF-RX018/250 B1250T
Analog Line Card	Mechanical Relay	TISP3xxxH3SL TISP7xxxH3SL 2X TISP4xxxH3BJ + TISP4xxxJ3BJ 2X TISP4xxxH3BJ 2035-35-SM	B1250T 4B06B-524-500 4A12P-516-500 MF-R016/600	TISP3xxxF3 TISP7xxxF3	MF-R012/250 MF-SM013/250	TISP3xxxF3 TISP7xxxF3	MF-R012/250 MF-SM013/250
Analog Line Card WLL	SLIC	TISP1xxxF3D TISP5xxxH3BJ TISP61089AD TISP61089BD TISP820xMD TISP83121DR	4B04B-524-500 B1250T 4B04B-524-500 MF-R016/600 4A12P-516-500 4B07-530-400	TISP1xxxF3 TISP61089 TISP61089 TISP820x TISP83121 TISP6NTP2x	MF-R012/250 MF-SM013/250 4B07B-530-400 4B04B-524-500 4B06B-514-500	TISP1xxxF3 TISP61089 TISP820x TISP83121 TISP6NTP2x	MF-R012/250 MF-SM013/250 4B07B-530-400 4B04B-524-500 4B06B-514-500
xDSL Line Card	Transformer/C	TISP4xxxH3BJ 2035-35-SM 2036-40-SM	B1250T MF-R016/600	TISP4xxxL3AJ TISP4xxxM3BJ TISP4xxxM3AJ 2036-40-SM	MF-R018/250	TISP4xxxL3AJ TISP4xxxM3BJ TISP4xxxM3AJ 2036-40-SM	MF-R018/250
Analog Line Card	Solid State Relay (LCAS)	TISP4A270BJ + TISP4125H3BJ TISP4219H3BJ + TISP4125H3BJ TISP4A265H3BJ + TISP4125H3BJ	B1250T 4B06B-540-125/219 MFR016/600 B1250T B1250T	TISPL758F3	MF-R012/250 MF-SM013/250 Various LPMs	TISPL758F3	MF-R012/250 MF-SM013/250 Various LPMs

Note: Central Office Primary Protection comes in various forms of 5-Pin protection modules, complying with UL 497, GR 974, GR 1361 and RUS-PE 80.

Customer Premises Equipment

		U.S.A. TIA-968-A UL 60950		International ITU-T K.21 & K.44 IEC 60950	
Application/ Function	Protected Element	Overtoltage Protection	Overcurrent Protection	Overtoltage Protection	Overcurrent Protection
DECT / 900 MHz / 2.4 GHz Phone	Hook Switch / Electronic Relay Rechargeable Battery	TISP4350H3LM TISP4350H3BJ CD214B-TxxxC	MF-R016/600 B1250T MF-VS210*	TISP4290F3LMx	MF-SM013/250 4B04B-503-500 4B06B-514-500 MF-VS210*
Phone	Hook Switch/ Electronic Relay	TISP4350T3BJ CD214B-Txxx 2035-35-SM	B1250T MF-R015/600		
Feature Phone	Hook Switch/ Electronic Relay	TISP4350MMBJ TISP4350MMAJ CD214B-Txxx 2035-35-SM	MF-R015/600-A MF-R015/600		
LAN Phone	Insulation	TISP4600/4700 CD214Cxxx 2035-60-SM	B1250T	TISP4600/4700	MF-SM013/250
Surge Bar Phone Port	Insulation	2035-60-SM			MF-R012/250
FAX	Hook Switch/ Mechanical Relay	2035-35-SM CD214B-Txxx	MF-R015/600		
Analog Modem	Hook Switch/ Mechanical Relay	TISP4350T3BJ 2035-35-SM CD214B-TxxxC	MF-R016/600 MF-R015/600-A B1250T	TISP4290L3AJ	MF-R012/250
Digital Modem	Transformer/C	2035-35-SM	MF-R015/600	2035-40	MF-R015/600
Set Top Box Modem	Hook Switch/ Electronic Relay USB Port*	TISP4350T3BJ 2035-35-SM CD214B-Txxx	B1250T MF-R015/600 MF-MSMF110	2035-35-SM	MF-MSMF110
Set Top Box DSL Modem	Transformer/C	TISP4395H3 CD214C-TxxxC 2035-35-SM	B1250T MF-R015/600	TISP4395L3 2035-40	MF-RX018/250
Set Top Box DSL Modem	SLIC DSL Transformer	TISP5xxxH3BJ CD214C-Txxx 2035-35-SM	B1250T MF-R015/600	TISP1072F3	LPM
Set Top Box	SLIC	TISP6NTP2xD CD214C-Txxx	MF-R015/600	TISP6NTP2x	4B06B-514-500 MF-R012/250 MF-SM013/250
Cable Telephony Data Port	Transformer Power Passing Tap*	TISP4350T3BJ CD214C-Txxx	MF-R015/600 MF-R055/90*	TISP4290L3AJ	MF-RX018/250 MF-R055/90*

*Different Regulatory Standards apply

Customer Premises Equipment – *continued*

		U.S.A. TIA-968-A UL 60950		International ITU-T K.21 & K.44 IEC 60950	
Application/ Function	Protected Element	Overvoltage Protection	Overcurrent Protection	Overvoltage Protection	Overcurrent Protection
POS Equipment	Hook Switch / Mechanical Relay Electric Motor*	2035-35-SM TISP4350H3BJ	MF-R015/600 B1250T MF-SM100*	2027-xx	MF-SM100*
Routers – LAN Linked	Insulation	2035-60-SM CD214B-Txxx			
Surge Bar Phone Port	Insulation	2035-60-SM CD214C-Txxx			
UPS			MF-R015/600		MF-R014/250
PABX	SLIC	TISP61089BD CD214A-Txxx	B1250T MF-R015/600	TISP61089	4B06B-514-500
WLL	SLIC	TISP1072F3DR	MF-R016/600	TISP820x	MF-R015/600
Pairgain	SLIC	TISP820xMD	MF-R015/600		
Home LAN	Transformer/C Power over Ethernet port*	TISP4350H3LM CD214A-Txxx	B1250T MF-SMDF050*	TISP4290F3LMx	MF-SMDF050*

*Different Regulatory Standards apply

Note: Primary Protection of Customer Premises Equipment is provided by our line of 5-Pin Building Entrance Modules and our conventional Station Protectors, Bourns® MSP®, IPA and Coax C-TV Protectors, complying to UL 497, 497C, GR 974, GR 1361 and RUS-PE 80. Various Network Interface Devices (NIDs) are available for these Customer Premises protectors.

ESD Protection Selection

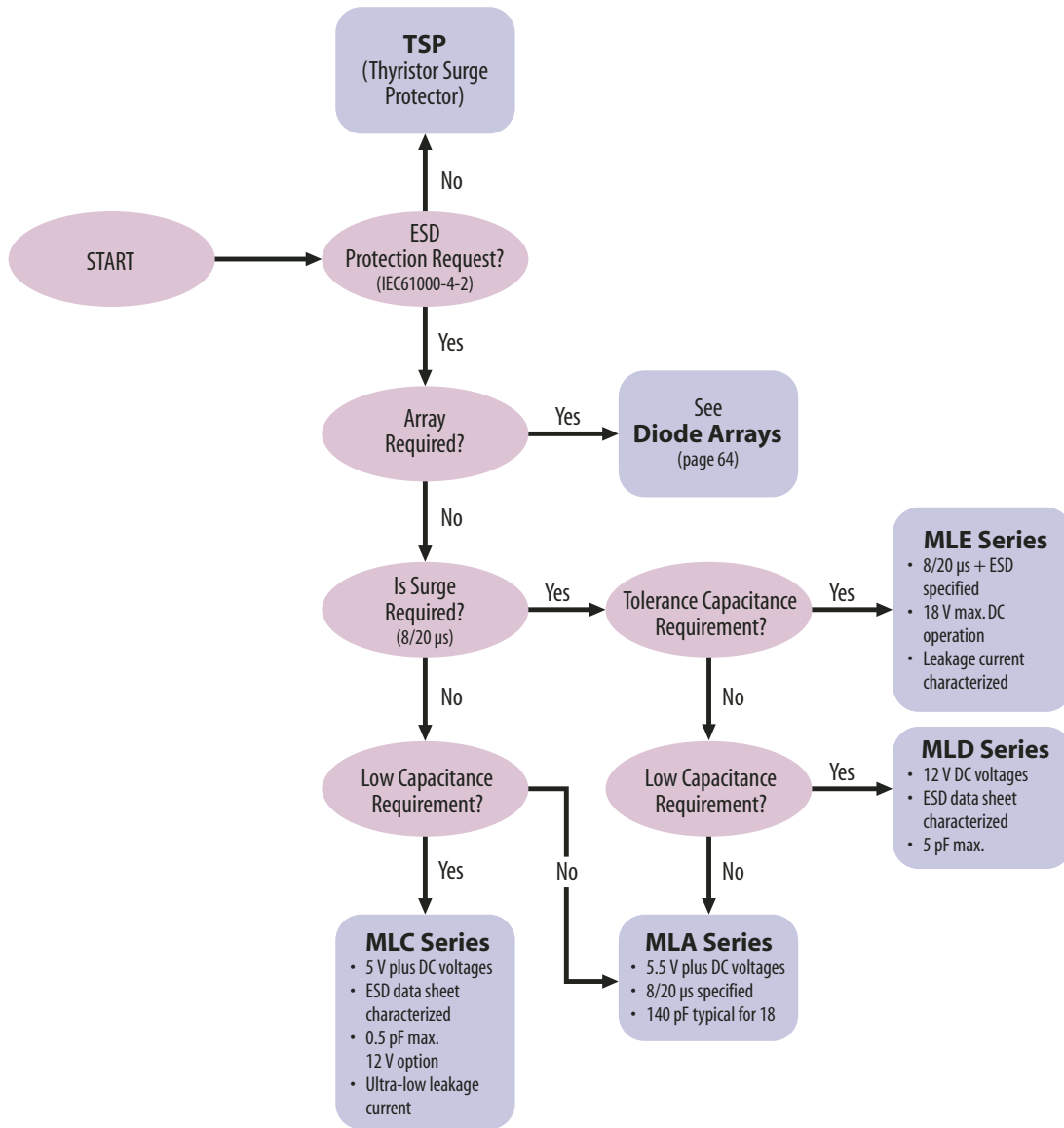

Other Devices

For Outside Plant Protectors, Signaling System Surge Protectors, Line Protection Modules, TVS Diodes and Telecom Transformers, please refer to the Product Selection Guides in the next section and/or contact your local representative for more information.

GDT – Gas Discharge Tubes

Selection Guide





Bourns® Gas Discharge Tubes (GDTs) prevent damage from overvoltages by acting as a “crowbar”, i.e. a short circuit. When a voltage surge exceeds the GDT’s defined sparkover voltage level (surge breakdown voltage), the GDT becomes ionized and conduction takes place within a fraction of a microsecond. When the surge passes and the system voltage returns to normal levels, the GDT returns to its high-impedance (off) state.

Features

- Unmatched performance and reliability
- Various lead configurations
- Smallest size in the industry
(Mini 2-Pole and MINI TRIGARD™)

- Very high surge handling capability
- Extremely low work function for long service life
- Low capacitance & insertion loss
- Highly symmetrical cross-ionization
- Non-radioactive materials
- Optional Switch-Grade Fail-Short Device
- “Crowbar” function to less than 10 V arc voltage
- Telcordia, RUS, ITU-T, IEC, IEEE and UL compliant
- Broadband network capable
- Through-hole, SMT and cassette mounting configurations available
- Surge Protector Test Set (Model 4010-01) available for GDTs and other technologies

3-Terminal GDTs (Switch-Grade Fail-Short Device option available)

Model	DC Sparkover Voltage	Max. Single Surge Rating (8/20 μs)	DC Surge Rating (8/20 μs)	AC Rating	Capacitance	Min. Surge Life Rating (10/1000 μs waveshape)
 2026-07 2026-09 2026-15 2026-20  2026-23 2026-25 2026-30 2026-35  2026-40 2026-42 2026-47 2026-60	75 V 90 V 150 V 200 V 230 V 250 V 300 V 350 V 400 V 420 V 470 V 600 V	40 kA	10 x 20 kA	10 x 20 A rms, 1 s	<2 pF	400 x 1000 A
 2036-07  2036-09 2036-15 2036-20 2036-23 2036-25  2036-30 2036-35 2036-40 2036-42 2036-47  2036-60	75 V 90 V 150 V 200 V 230 V 250 V 300 V 350 V 400 V 420 V 470 V 600 V	20 kA	10 x 10 kA	10 x 10 A rms, 1 s	<2 pF	300 x 200 A or 500 x 200 A 10/700 μs

The rated discharge current for 3-Electrode GDTs is the total current equally divided between each line to ground.



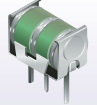
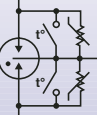



3-Terminal GDTs (Switch-Grade Fail-Short Device option available) – *continued*

Model	DC Sparkover Voltage	Max. Single Surge Rating (8/20 μ s)	DC Surge Rating (8/20 μ s)	AC Rating	Capacitance	Min. Surge Life Rating (10/1000 μ s waveshape)
 2026-23-xx-MSP	230 V	40 kA	10 x 20 kA	20 x 10 A rms, 1 s	<20 pF	1000 x 1000 A
 2026-33-xx-MSP	330 V					

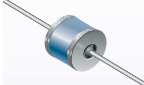
MSP® = Multi-Stage Protection. MSP® devices have a patented Switch-Grade Fail-Short Device as standard configuration and contains 2 miniature MOVs in parallel with each line.

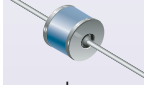
The rated discharge current for 3-Electrode GDTs is the total current equally divided between each line to ground.

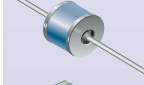
2-Terminal GDTs

Model	DC Sparkover Voltage	Max. Single Surge Rating (8/20 μ s)	DC Surge Rating (8/20 μ s)	AC Rating	Capacitance	Min. Surge Life Rating (10/1000 μ s waveshape)
  2027-09 2027-15 2027-20 2027-23 2027-25 2027-30 2027-35 2027-40 2027-42 2027-47 2027-60	90 V 150 V 200 V 230 V 250 V 300 V 350 V 400 V 420 V 470 V 600 V	20 kA	10 x 10 kA	10 x 10 A rms, 1 s	<1 pF	400 x 500 A
   2037-09 2037-15 2037-20 2037-23 2037-25 2037-30 2037-35 2037-40 2037-42 2037-47 2037-60	90 V 150 V 200 V 230 V 250 V 300 V 350 V 400 V 420 V 470 V 600 V	10 kA	10 x 5 kA	10 x 5 A rms, 1 s	<1 pF	300 x 100 A or 500 x 100 A 10/700 μ s
    2035-09 2035-15 2035-20 2035-23 2035-25 2035-30 2035-35 2035-40 2035-42 2035-47 2035-60	90 V 150 V 200 V 230 V 250 V 300 V 350 V 400 V 420 V 470 V 600 V	10 kA	10 x 5 kA	10 x 5 A rms, 1 s	<2 pF	300 x 100 A or 500 x 100 A 10/700 μ s

GDT Product Dimensions

2026-XX-A

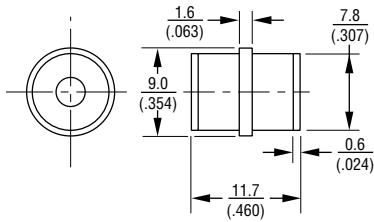

2026-XX-A1

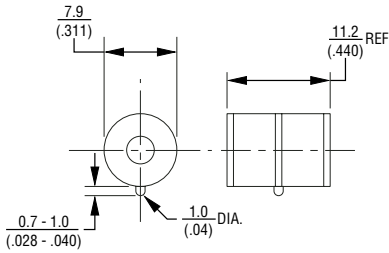

2026-XX-C2

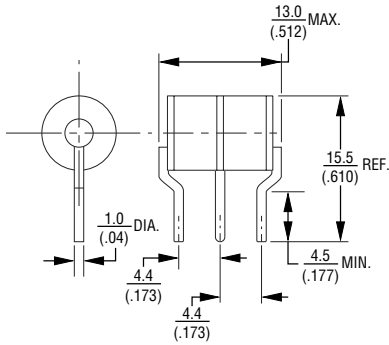

2026-XX-C3

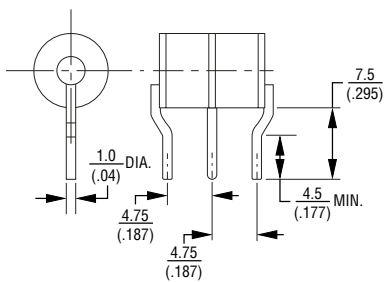

2026-XX-C8

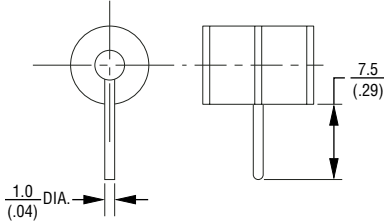

2026-XX-C13

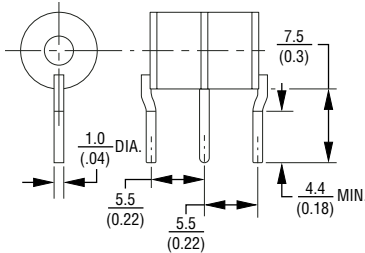

2026-XX-C14

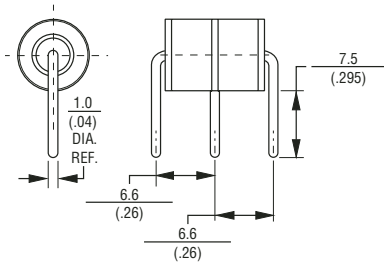

2026-XX-C18

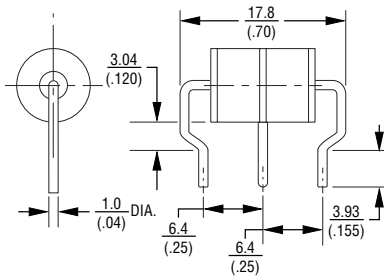

2026-XX-C – 1.0 mm (0.040 ") dia. lead wire
2026-XX-CB – 0.8 mm (0.032 ") dia. lead wire

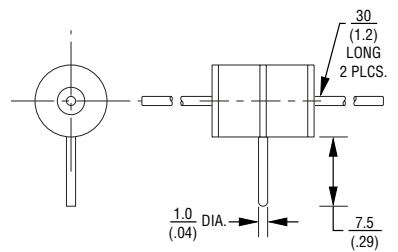

Fail-Short Configuration
2026-XX-C2F Shown

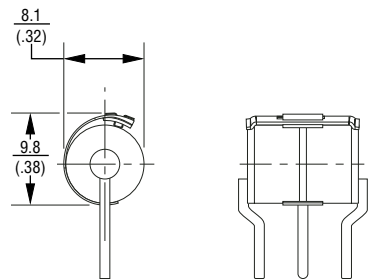

DIMENSIONS = $\frac{\text{MILLIMETERS}}{\text{(INCHES)}}$

Specifications are subject to change without notice.
 Customers should verify actual device performance in their specific applications.

GDT Product Dimensions

2036-XX-A

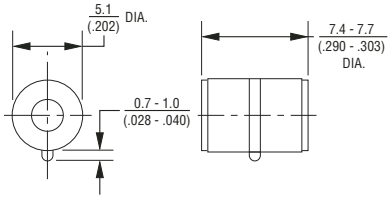

2036-XX-B2 – 0.8 mm (0.032 ") dia. lead wire 2036-XX-C2 – 1.0 mm (0.040 ") dia. lead wire*

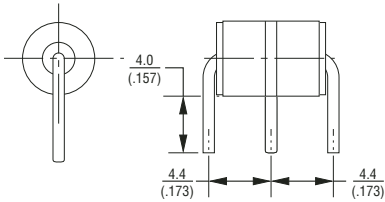

2036-XX-B3 – 0.8 mm (0.032 ") dia. lead wire 2036-XX-C3 – 1.0 mm (0.040 ") dia. lead wire*

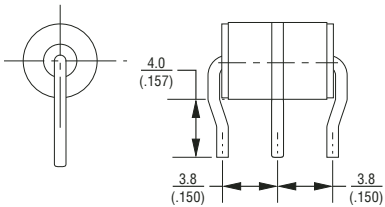

2036-XX-B9 – 0.8 mm (0.032 ") dia. lead wire 2036-XX-C9 – 1.0 mm (0.040 ") dia. lead wire*

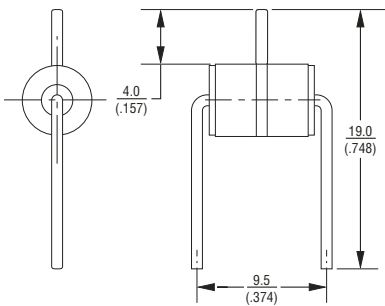

*Center Electrode Lead:
See Center Lead C-Configuration detail.

2036-XX-B – 0.8 mm (0.032 ") dia. lead wire 2036-XX-C – 1.0 mm (0.040 ") dia. lead wire*

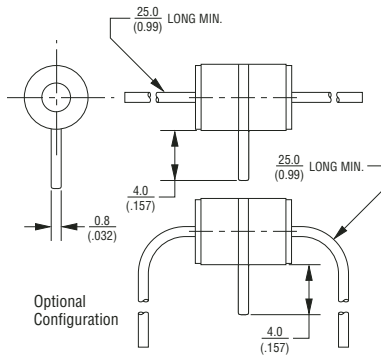

2036-XX-B8 – 0.8 mm (0.032 ") dia. lead wire 2036-XX-C8 – 1.0 mm (0.040 ") dia. lead wire*

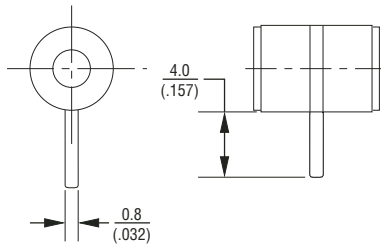

Fail-Short Configuration 2036-XX-B2F Shown

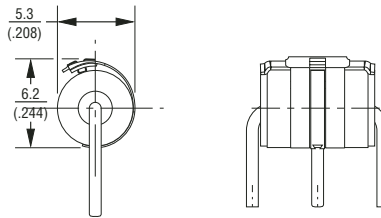

Center Electrode Lead: C-Configuration

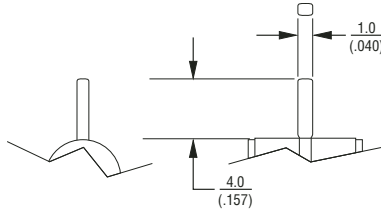

DIMENSIONS = $\frac{\text{MILLIMETERS}}{\text{(INCHES)}}$

2026-XX-C2M1XX

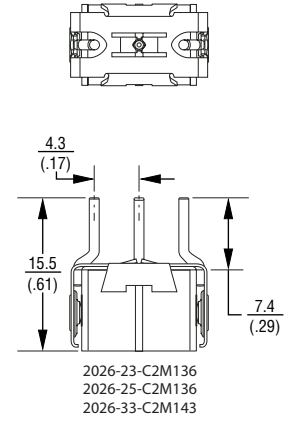

2026-XX-C16M1XX

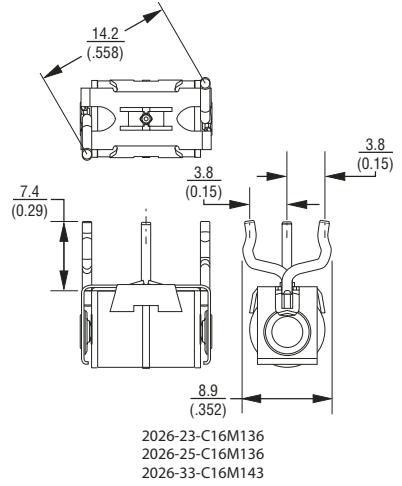

2026-XX-C4M1XX

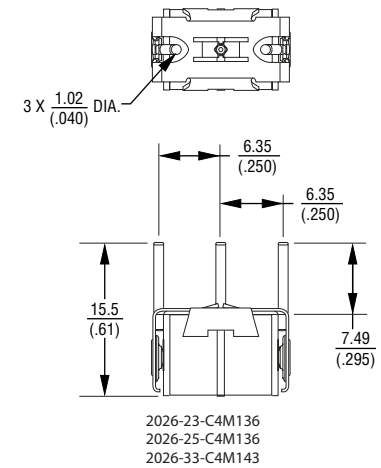

Specifications are subject to change without notice.
Customers should verify actual device performance in their specific applications.

GDT Product Dimensions

2027-XX-A

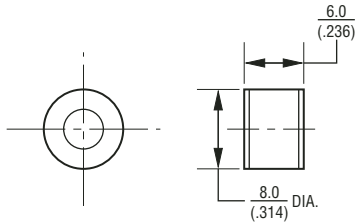

2027-XX-BT1 – 0.8 mm (0.032 ") dia. lead wire

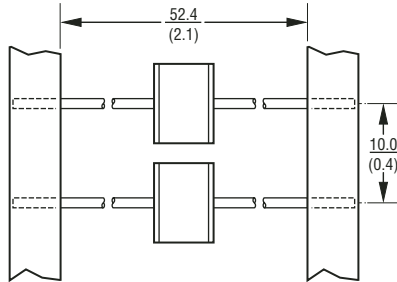

2027-XX-B – 0.8 mm (0.032 ") dia. lead wire

2027-XX-C – 1.0 mm (0.040 ") dia. lead wire

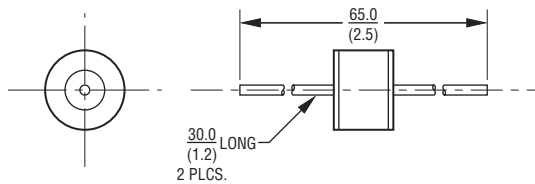

2027-XX-B10 – 0.8 mm (0.032 ") dia. lead wire

2027-XX-C10 – 1.0 mm (0.040 ") dia. lead wire

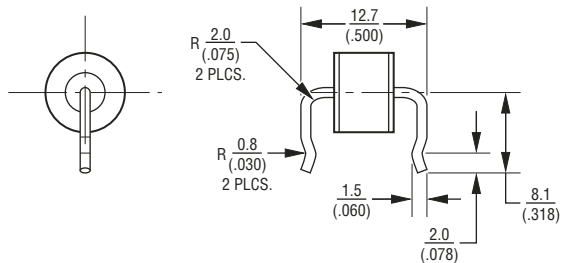

2035-XX-A

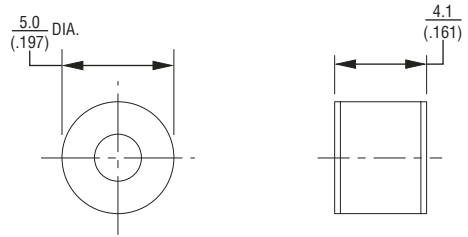

2035-XX-B – 0.8 mm (0.032 ") dia. lead wire

2035-XX-C – 1.0 mm (0.040 ") dia. lead wire

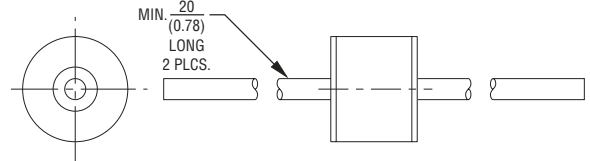

2035-XX-B5 – 0.8 mm (0.032 ") dia. lead wire

2035-XX-C5 – 1.0 mm (0.040 ") dia. lead wire

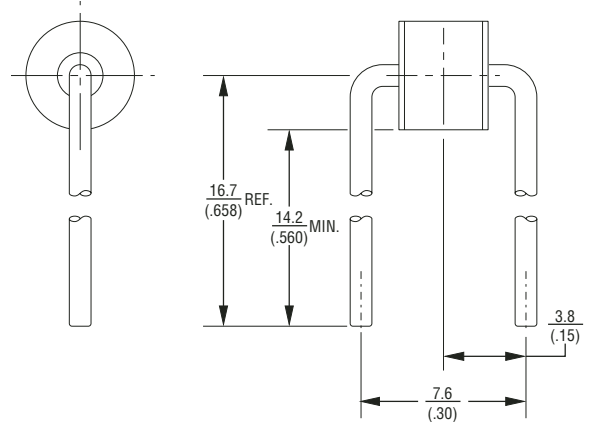

DIMENSIONS = $\frac{\text{MILLIMETERS}}{\text{(INCHES)}}$

Specifications are subject to change without notice.
Customers should verify actual device performance in their specific applications.

GDT Product Dimensions

2037-XX-A

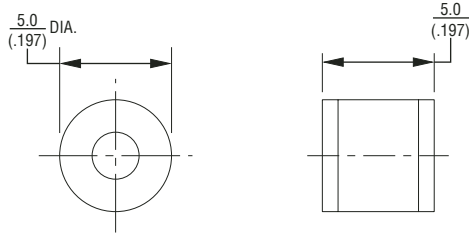

2037-XX-B – 0.8 mm (0.032 ") dia. lead wire 2037-XX-C – 1.0 mm (0.040 ") dia. lead wire

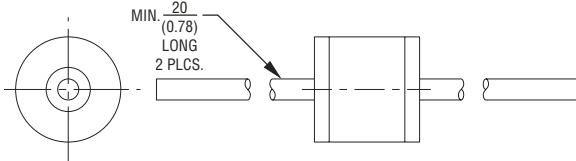

2037-XX-B5 – 0.8 mm (0.032 ") dia. lead wire 2037-XX-C5 – 1.0 mm (0.040 ") dia. lead wire

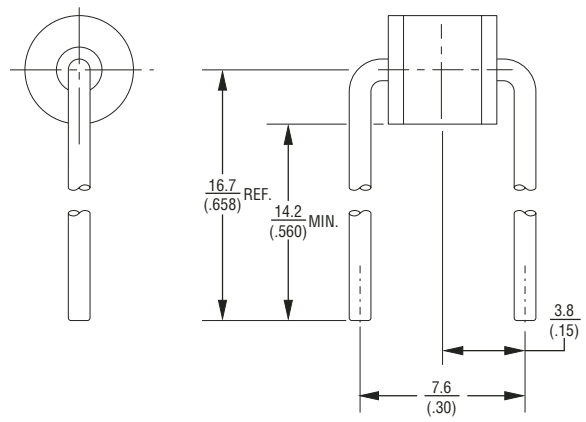

2035-XX-SM

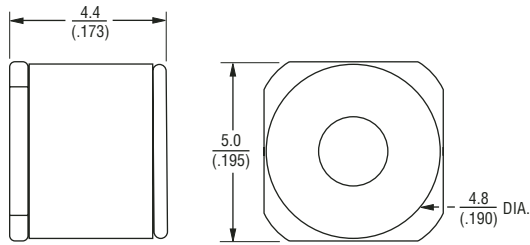

Recommended Pad Layout

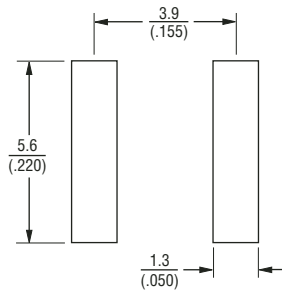

2036-XX-SM

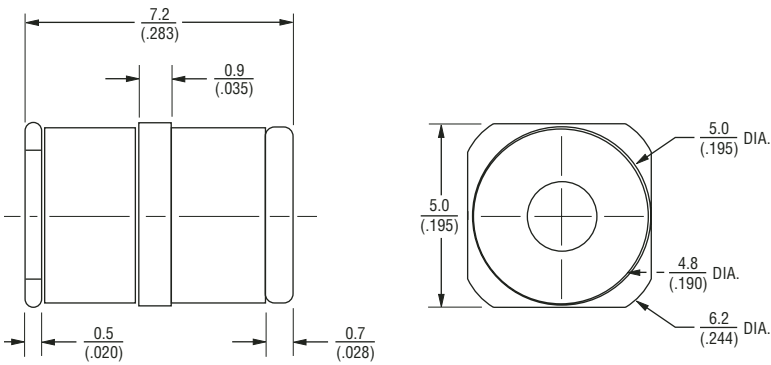

Recommended Pad Layout

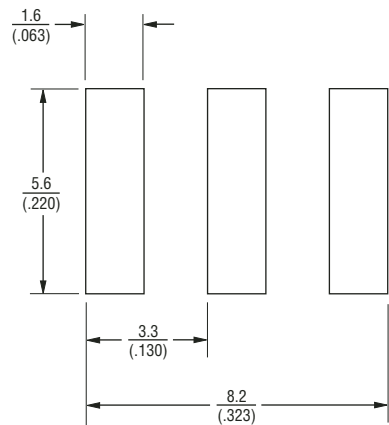

DIMENSIONS = $\frac{\text{MILLIMETERS}}{\text{(INCHES)}}$

Specifications are subject to change without notice.
Customers should verify actual device performance in their specific applications.

Bourns® TISP® Thyristor Surge Protectors





Selection Guide

Bourns® TISP® thyristor surge protector products prevent damage from overvoltages, as these silicon based devices initially clamp the line voltage to limit overvoltages on telephone lines, then switch to a low voltage “On” state. After the surge, when the current drops below the “holding current,” the protector returns to its original high impedance state.

Features

- Extensive range offering multiple voltage variants
- Surface mount and through-hole packages
- Designed to withstand international lightning.

Fixed Voltage

Series	Device Symbol	Applications
TISP1xxx Dual Unidirectional		• SLIC Line Card
TISP3xxx TISPL758L Dual Bidirectional		• 3 Wire Ground Backed Ringer • Solid State Relay • Surge Bars
TISP4xxx Single Bidirectional		• Modems • Telephones • Fax Machines • xDSL • Set Top Boxes • Surge Bars
TISP5xxx Single Unidirectional		• SLIC Line Card • ISDN
TISP70xx Triple Unidirectional		• xDSL • ISDN • T1/E1/E3

Gated (Programmable) Voltage

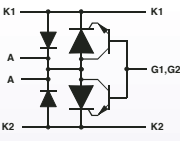
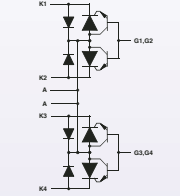
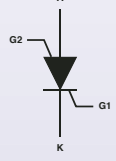
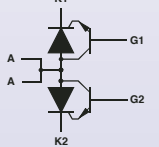
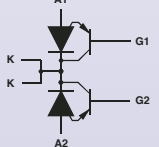
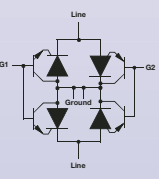
Series	Device Symbol	Applications
TISP6xxx TISPPBLx Dual Programmable		• SLIC Line Card • Ericsson PBL3xx SLIC
TISP6NTP2x Quad Programmable		• Dual SLIC Lines • Cable Modems • ISDN Power Feeds • Smart NT • Set Top Boxes
TISP83121 Dual Gate Unidirectional		• Positive & Negative Polarity Ringing SLICs
TISP8200 Dual Programmable Unidirectional for Negative Polarity		• Analog Line Card • Dual Supply Ringing SLIC
TISP8201 Dual Programmable Unidirectional for Positive Polarity		TISP8200 & TISP8201 typically used as a complementary pair
TISP9xxx Integrated Complementary Buffered-Gate Protector for Dual Polarity Protection		• CO & Access Equipment Line Cards • Protection of Dual Polarity Ringing SLICs

Telecom System Primary Overvoltage Protection

Series	Applications
2ELx 7ELx	Single Bidirectional • Solid state replacement for Gas Discharge Tubes

TISP1xxxF3 Series – Dual Unidirectional Overvoltage Protectors ($I_H = -150 \text{ mA}$)

General fixed voltage SLIC protection for Line Cards and VOIP

Device	Delivery Options	Standoff Voltage V_{DRM} (V)	Protection Voltage $V_{(BO)}$ (V)	I_{TSP} Ratings for Lightning Surge Standards			
				GR-1089-CORE 2/10 μs (A)	GR-1089-CORE 10/1000 μs (A)	ITU-T K20/21 5/310 μs (A)	
	TISP1072F3	DR, P, SL	-58	-72	80	35	50
	TISP1082F3	DR, P, SL	-66	-82			

TISP1xxxH3 Series – Dual Unidirectional Overvoltage Protectors ($I_H = -150 \text{ mA}$)

SLIC protection for Line Cards and VOIP

Device	Delivery Options	Standoff Voltage V_{DRM} (V)	Protection Voltage $V_{(BO)}$ (V)	I_{TSP} Ratings for Lightning Surge Standards			
				GR-1089-CORE 2/10 μs (A)	GR-1089-CORE 10/1000 μs (A)	ITU-T K20/21 5/310 μs (A)	
	TISP1070H3	BJR	-58	-70	500	100	150
	TISP1080H3	BJR	-65	-80			
	TISP1095H3	BJR	-75	-95			
	TISP1120H3	BJR	-95	-120			

TISP3xxx Series – Dual Bidirectional Overvoltage Protectors ($I_H = 150\text{ mA}$)

Legerity and Intersil Line Card Access Switch (LCAS) protection, L7581/2/3 protection – TISPL758L3

General 3-point protection – TISP3xxxF3

CO Line Card and CPE modem protection where a ground is available – TISP3xxxT3

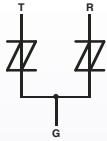
Device	Delivery Options	Standoff Voltage V_{DRM} (V)	Protection Voltage $V_{(BO)}$ (V)	ITSP Ratings for Lightning Surge Standards			
				GR-1089-CORE 2/10 μs (A)	GR-1089-CORE 10/1000 μs (A)	ITU-T K20/21 5/310 μs (A)	
	TISPL758LF3 ¹	DR	105, 180	130, 220	175	35	50
	TISP3072F3	DR, P, SL	58	72	80	35	50
	TISP3082F3	DR, P, SL	66	82			
	TISP3125F3	DR, P, SL	100	125			
	TISP3150F3	DR, P, SL	120	150	175	35	50
	TISP3180F3	DR, P, SL	145	180			
	TISP3240F3	DR, P, SL	180	240			
	TISP3260F3	DR, P, SL	200	260			
	TISP3290F3	DR, P, SL	220	290			
	TISP3320F3	DR, P, SL	240	320			
	TISP3380F3	DR, P, SL	270	380			
	TISP3600F3	SL	420	600	190	45	70
	TISP3700F3	SL	500	700			
	TISP3070T3	BJR	58	70	250	80	120
	TISP3080T3	BJR	65	80			
	TISP3095T3	BJR	75	95			
	TISP3115T3	BJR	90	115			
	TISP3125T3	BJR	100	125			
	TISP3145T3	BJR	120	145			
	TISP3165T3	BJR	135	165			
	TISP3180T3	BJR	145	180			
	TISP3200T3	BJR	155	200			
	TISP3219T3	BJR	180	219			
	TISP3250T3	BJR	190	250			
	TISP3290T3	BJR	220	290			
	TISP3350T3	BJR	275	350			
	TISP3395T3	BJR	320	395			
	TISP3070H3	SL	58	70	500	100	200
	TISP3080H3	SL	65	80			
	TISP3095H3	SL	75	95			
TISP3115H3	SL	90	115				
TISP3125H3	SL	100	125				
TISP3135H3	SL	110	135				
TISP3145H3	SL	120	145				
TISP3180H3	SL	145	180				
TISP3210H3	SL	160	210				
TISP3250H3	SL	190	250				
TISP3290H3	SL	220	290				
TISP3350H3	SL	275	350				

TISP4xxxF3 Series – Single Bidirectional Overvoltage Protectors ($I_H = 150 \text{ mA}$)

General purpose 2-point protection

Device	Delivery Options	Standoff Voltage V_{DRM} (V)	Protection Voltage $V_{(BO)}$ (V)	ITSP Ratings for Lightning Surge Standards			
				GR-1089-CORE 2/10 μs (A)	GR-1089-CORE 10/1000 μs (A)	ITU-T K20/21 5/310 μs (A)	
	TISP4072F3	LM, LMR, LMFR	58	72	80	35	50
	TISP4082F3	LM, LMR, LMFR	66	82			
	TISP4125F3	LM, LMR, LMFR	100	125	175	35	50
	TISP4150F3	LM, LMR, LMFR	120	150			
	TISP4180F3	LM, LMR, LMFR	145	180			
	TISP4240F3	LM, LMR, LMFR	180	240			
	TISP4260F3	LM, LMR, LMFR	200	260			
	TISP4290F3	LM, LMR, LMFR	220	290			
	TISP4320F3	LM, LMR, LMFR	240	320			
	TISP4380F3	LM, LMR, LMFR	270	380	190	45	70
	TISP4600F3	LM, LMR, LMFR	420	600			
	TISP4700F3	LM, LMR, LMFR	500	700			

TISP4xxxL1 Series – Single Bidirectional Overvoltage Protectors ($I_H = 50 \text{ mA}$)

Dataline protection such as E1/T1 or xDSL with ITU-T compliance

Ideal for use with MF-RX018/250 Multifuse® PPTC device

Device	Delivery Options	Standoff Voltage V_{DRM} (V)	Protection Voltage $V_{(BO)}$ (V)	ITSP Ratings for Lightning Surge Standards			
				GR-1089-CORE 2/10 μs (A)	GR-1089-CORE 10/1000 μs (A)	ITU-T K20/21 5/310 μs (A)	
	TISP4015L1	AJR, BJR	8	15	150	30	45
	TISP4030L1	AJR, BJR	15	30			
	TISP4040L1	AJR, BJR	25	40			

TISP4xxxL3 Series – Single Bidirectional Overvoltage Protectors ($I_H = 150 \text{ mA}$)

General 2-point protection for European applications

Ideal for use with MF-SM013/250 Multifuse® PPTC device

Device	Delivery Options	Standoff Voltage V_{DRM} (V)	Protection Voltage $V_{(BO)}$ (V)	I_{TSP} Ratings for Lightning Surge Standards			
				GR-1089-CORE 2/10 μs (A)	GR-1089-CORE 10/1000 μs (A)	ITU-T K20/21 5/310 μs (A)	
	TISP4070L3	AJR	58	70	125	30	50
	TISP4080L3	AJR	65	80			
	TISP4090L3	AJR	70	90			
	TISP4125L3	AJR	100	125			
	TISP4145L3	AJR	120	145			
	TISP4165L3	AJR	135	165			
	TISP4180L3	AJR	145	180			
	TISP4220L3	AJR	160	220			
	TISP4240L3	AJR	180	240			
	TISP4260L3	AJR	200	260			
	TISP4290L3	AJR	230	290			
	TISP4320L3	AJR	240	320			
	TISP4350L3	AJR	275	350			
	TISP4360L3	AJR	290	360			
	TISP4395L3	AJR	320	395			

TISP4xxxL3 Series – Single Bidirectional Overvoltage Protectors ($I_H = 150 \text{ mA}$)

General 2-point protection for European applications

Ideal for use with MF-SM013/250 Multifuse® PPTC device

Device	Delivery Options	Standoff Voltage V_{DRM} (V)	Protection Voltage $V_{(BO)}$ (V)	I_{TSP} Ratings for Lightning Surge Standards			
				TIA-968-A 10/160 μs (A)	TIA-968-A 5/310 μs (A)	TIA-968-A 10/560 μs (A)	
	TISP4070L3	BJR	58	70	50	40	30
	TISP4350L3	BJR	275	350			

TISP4xxxMM Series – Single Bidirectional Overvoltage Protectors ($I_H = 150 \text{ mA}$)

General 2-point protection for European applications

Ideal for use with MF-SM013/250 Multifuse® PPTC device

Device	Delivery Options	Standoff Voltage V_{DRM} (V)	Protection Voltage $V_{(BO)}$ (V)	I_{TSP} Ratings for Lightning Surge Standards			
				GR-1089-CORE 2/10 μs (A)	GR-1089-CORE 10/1000 μs (A)	ITU-T K20/21 5/310 μs (A)	
	TISP4300MM	AJR, BJR	230	300	250	55	50
	TISP4350MM	AJR, BJR	275	350			
	TISP4360MM	AJR, BJR	290	360			

TISP4xxxM3 Series – Single Bidirectional Overvoltage Protectors ($I_H = 150 \text{ mA}$)

General 2-point protection

Ideal for use with MF-SM013/250 Multifuse® PPTC device

Device	Delivery Options	Standoff Voltage V_{DRM} (V)	Protection Voltage $V_{(BO)}$ (V)	ITSP Ratings for Lightning Surge Standards			
				GR-1089-CORE 2/10 μs (A)	GR-1089-CORE 10/1000 μs (A)	ITU-T K20/21 5/310 μs (A)	
	TISP4070M3	AJR, BJR, LM, LMR, LMFR	58	70	300	50	100
	TISP4080M3	AJR, BJR, LM, LMR, LMFR	65	80			
	TISP4095M3	AJR, BJR, LM, LMR, LMFR	75	95			
	TISP4115M3	AJR, BJR, LM, LMR, LMFR	90	115			
	TISP4125M3	AJR, BJR, LM, LMR, LMFR	100	125			
	TISP4145M3	AJR, BJR, LM, LMR, LMFR	120	145			
	TISP4165M3	AJR, BJR, LM, LMR, LMFR	135	165			
	TISP4180M3	AJR, BJR, LM, LMR, LMFR	145	180			
	TISP4200M3	AJR, BJR	155	200			
	TISP4219M3	BJR	180	219			
	TISP4220M3	AJR, BJR, LM, LMR, LMFR	160	220			
	TISP4240M3	AJR, BJR, LM, LMR, LMFR	180	240			
	TISP4250M3	AJR, BJR, LM, LMR, LMFR	190	250			
	TISP4260M3	LM, LMR, LMFR	200	260			
	TISP4265M3	AJR, BJR, LM, LMR, LMFR	200	265			
	TISP4290M3	AJR, BJR, LM, LMR, LMFR	220	290			
	TISP4300M3	AJR, BJR, LM, LMR, LMFR	230	300			
	TISP4350M3	AJR, BJR, LM, LMR, LMFR	275	350			
	TISP4360M3	AJR, BJR, LM, LMR, LMFR	290	360			
	TISP4395M3	AJR, BJR, LM, LMR, LMFR	320	395			
TISP4400M3	BJR, LM, LMR, LMFR	300	400				

TISP4xxxT3 Series – Single Bidirectional Overvoltage Protectors for Modem Protection ($I_H = 150 \text{ mA}$)

TIA-968-A protection

Ideal for use with Telefuse™ B1250 or Multifuse® MF-R015/600 PPTC device

Device	Delivery Options	Standoff Voltage V_{DRM} (V)	Protection Voltage $V_{(BO)}$ (V)	ITSP Ratings for Lightning Surge Standards			
				GR-1089-CORE 2/10 μs (A)	GR-1089-CORE 10/1000 μs (A)	ITU-T K20/21 5/310 μs (A)	
	TISP4290T3	BJR	220	290	250	80	120
	TISP4350T3	BJR	275	350			
	TISP4400T3	BJR	335	400			

TISP4xxxH1 Series – Single Bidirectional Overvoltage Protectors ($I_H = 50 \text{ mA}$)

Dataline protection such as E1/T1 or xDSL with GR-1089-CORE compliance

Device	Delivery Options	Standoff Voltage V_{DRM} (V)	Protection Voltage $V_{(BO)}$ (V)	I_{TSP} Ratings for Lightning Surge Standards			
				GR-1089-CORE 2/10 μs (A)	GR-1089-CORE 10/1000 μs (A)	ITU-T K20/21 5/310 μs (A)	
	TISP4015H1	BJR	8	15	500	100	150
	TISP4030H1	BJR	15	30			
	TISP4040H1	BJR	25	40			

TISP4xxxH3 Series – Single Bidirectional Overvoltage Protectors ($I_H = 150 \text{ mA}$)

General telecom protection, either for enhanced ITU-T or Telecordia GR-1089-CORE designs

Ideal for use with Telefuse™ B1250T and Multifuse® MF-R015/600 PPTC device

Device	Delivery Options	Standoff Voltage V_{DRM} (V)	Protection Voltage $V_{(BO)}$ (V)	I_{TSP} Ratings for Lightning Surge Standards			
				GR-1089-CORE 2/10 μs (A)	GR-1089-CORE 10/1000 μs (A)	ITU-T K20/21 5/310 μs (A)	
	TISP4070H3	BJR, LM, LMR, LMFR	58	70	500	100	200
	TISP4080H3	BJR, LM, LMR, LMFR	65	80			
	TISP4095H3	BJR, LM, LMR, LMFR	75	95			
	TISP4115H3	BJR, LM, LMR, LMFR	90	115			
	TISP4125H3	BJR, LM, LMR, LMFR	100	125			
	TISP4145H3	BJR, LM, LMR, LMFR	120	145			
	TISP4165H3	BJR, LM, LMR, LMFR	135	165			
	TISP4180H3	BJR, LM, LMR, LMFR	145	180			
	TISP4200H3	BJR, LM, LMR, LMFR	155	200			
	TISP4219H3	BJR	180	219			
	TISP4220H3	BJR	160	220			
	TISP4240H3	BJR, LM, LMR, LMFR	180	240			
	TISP4250H3	BJR, LM, LMR, LMFR	190	250			
	TISP4260H3	LM, LMR, LMFR	200	260			
	TISP4265H3	BJR	200	265			
	TISP4290H3	BJR, LM, LMR, LMFR	220	290			
	TISP4300H3	BJR, LM, LMR, LMFR	230	300			
	TISP4350H3	BJR, LM, LMR, LMFR	275	350			
	TISP4360H3	BJR	290	360			
	TISP4395H3	BJR, LM, LMR, LMFR	320	395			
TISP4400H3	BJR, LM, LMR, LMFR	300	400				
TISP4500H3	BJR	320	500				

TISP4CxxxH3 Series – Low Capacitance Single Bidirectional Overvoltage Protectors ($I_H = 150 \text{ mA}$)

General low capacitance telecom protection for xDSL or data applications

Device	Delivery Options	Standoff Voltage V_{DRM} (V)	Protection Voltage $V_{(BO)}$ (V)	ITSP Ratings for Lightning Surge Standards			
				GR-1089-CORE 2/10 μs (A)	GR-1089-CORE 10/1000 μs (A)	ITU-T K20/21 5/310 μs (A)	
	TISP4C290H3	BJR	220	290	500	100	150
	TISP4C350H3	BJR	275	350			
	TISP4C395H3	BJR	320	395			

TISP4xxxH4 Series – Single Bidirectional Overvoltage Protectors ($I_H = 225 \text{ mA}$)

Full temperature general overvoltage protection, where holding current must exceed 150 mA

Device	Delivery Options	Standoff Voltage V_{DRM} (V)	Protection Voltage $V_{(BO)}$ (V)	ITSP Ratings for Lightning Surge Standards			
				GR-1089-CORE 2/10 μs (A)	GR-1089-CORE 10/1000 μs (A)	ITU-T K20/21 5/310 μs (A)	
	TISP4165H4	BJR	135	165	500	100	200
	TISP4180H4	BJR	145	180			
	TISP4200H4	BJR	155	200			
	TISP4265H4	BJR	200	265			
	TISP4300H4	BJR	230	300			
	TISP4350H4	BJR	270	350			

TISP4xxxJ1 Series – Single Bidirectional Overvoltage Protectors ($I_H = 20 \text{ mA}$)

General high current dry line data protection or bottom element in a “Y” protection solution

Device	Delivery Options	Standoff Voltage V_{DRM} (V)	Protection Voltage $V_{(BO)}$ (V)	ITSP Ratings for Lightning Surge Standards			
				GR-1089-CORE 2/10 μs (A)	GR-1089-CORE 10/1000 μs (A)	ITU-T K20/21 5/310 μs (A)	
	TISP4070J1	BJR	58	70	1000	200	350
	TISP4080J1	BJR	65	80			
	TISP4095J1	BJR	75	95			
	TISP4115J1	BJR	90	115			
	TISP4125J1	BJR	100	125			
	TISP4145J1	BJR	120	145			
	TISP4165J1	BJR	135	165			
	TISP4180J1	BJR	145	180			
	TISP4200J1	BJR	155	200			
	TISP4219J1	BJR	180	219			
	TISP4250J1	BJR	190	250			
	TISP4290J1	BJR	220	290			
	TISP4350J1	BJR	275	350			
	TISP4395J1	BJR	320	395			

TISP4xxxJ3 Series – Single Bidirectional Overvoltage Protectors ($I_H = 150 \text{ mA}$)

High current POTS protection or powered xDSL protection

Device	Delivery Options	Standoff Voltage V_{DRM} (V)	Protection Voltage $V_{(BO)}$ (V)	I_{TSP} Ratings for Lightning Surge Standards			
				GR-1089-CORE 2/10 μs (A)	GR-1089-CORE 10/1000 μs (A)	ITU-T K20/21 5/310 μs (A)	
	TISP4290J3	BJR	220	290	1000	200	350
	TISP4350J3	BJR	275	350			
	TISP4395J3	BJR	320	395			

TISP5xxxH3 Series – Single Unidirectional Overvoltage Protectors ($I_H = -150 \text{ mA}$)

General fixed voltage SLIC protection ideal for VOIP applications

Device	Delivery Options	Standoff Voltage V_{DRM} (V)	Protection Voltage $V_{(BO)}$ (V)	I_{TSP} Ratings for Lightning Surge Standards			
				GR-1089-CORE 2/10 μs (A)	GR-1089-CORE 10/1000 μs (A)	ITU-T K20/21 5/310 μs (A)	
	TISP5070H3	BJR	-58	-70	500	100	200
	TISP5070H3	BJR	-65	-80			
	TISP5110H3	BJR	-80	-110			
	TISP5115H3	BJR	-90	-115			
	TISP5150H3	BJR	-120	-150			
	TISP5190H3	BJR	-160	-190			

TISP7xxxL1 Series – Triple Bidirectional Overvoltage Protectors ($I_H = 30 \text{ mA}$)

Balanced 3-point protection for ISDN or xDSL data communications applications

Device	Delivery Options	Standoff Voltage V_{DRM} (V)	Protection Voltage $V_{(BO)}$ (V)	I_{TSP} Ratings for Lightning Surge Standards			
				TIA-968-A 10/160 μs (A)	TIA-968-A 5/310 μs (A)	TIA-968-A 10/560 μs (A)	
	TISP7015L1	DR	8	15	200	30	50
	TISP7038L1	DR	28	38			

TISP7xxx Series – Triple Bidirectional Overvoltage Protectors ($I_H = 150\text{ mA}$)

General balanced 3-point protection – TISP70xxF3

General balanced 3-point protection typically for European ITU-T applications – TISP7xxxF3

General balanced 3-point protection typically for Telecordia GR-1089-CORE applications – TISP7xxxH3

Device	Delivery Options	Standoff Voltage V_{DRM} (V)	Protection Voltage $V_{(BO)}$ (V)	ITSP Ratings for Lightning Surge Standards			
				GR-1089-CORE 2/10 μs (A)	GR-1089-CORE 10/1000 μs (A)	ITU-T K20/21 5/310 μs (A)	
	TISP7072F3	DR, P, SL	58	72	85	45	70
	TISP7082F3	DR, P, SL	66	82			
	TISP7125F3	DR, P, SL	100	125	190	45	70
	TISP7150F3	DR, P, SL	120	150			
	TISP7180F3	DR, P, SL	145	180			
	TISP7240F3	DR, P, SL	180	240			
	TISP7260F3	DR, P, SL	200	260			
	TISP7290F3	DR, P, SL	220	290			
	TISP7320F3	DR, P, SL	240	320			
	TISP7350F3	DR, P, SL	275	350			
TISP7380F3	DR, P, SL	270	380				
TISP7070H3	SL	58	70	500			
TISP7080H3	SL	65	80				
TISP7095H3	SL	75	95				
TISP7125H3	SL	100	125				
TISP7135H3	SL	110	135				
TISP7145H3	SL	120	145				
TISP7165H3	SL	130	165				
TISP7180H3	SL	145	180				
TISP7200H3	SL	150	200				
TISP7210H3	SL	160	210				
TISP7220H3	SL	160	210				
TISP7250H3	SL	200	250				
TISP7290H3	SL	230	290				
TISP7350H3	SL	275	350				
TISP7400H3	SL	300	400				

TISP6xxx Series – Programmable Overvoltage Protectors for SLIC Protection

Ringing SLIC protection for CO and VOIP applications

Alternative to Legerity (Previously Lucent) L7591 protector – TISPL7591

Infineon (previously Ericsson) PBL386 SLIC protection – TISPPBL1, BL2, BL3

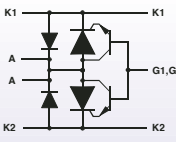
Device	Delivery Options	Standoff Voltage V_{DRM} (V)	Protection Voltage $V_{(BO)}$ (V)	ITSP Ratings for Lightning Surge Standards		
				GR-1089-CORE 2/10 μ s (A)	GR-1089-CORE 10/1000 μ s (A)	ITU-T K20/21 5/310 μ s (A)
	TISP61089H	DM	Programmable -20 to -170 V	500	100	150
	TISP61060	DR, P	Programmable -5 to -85 V	50	30	40
	TISP61089	DR, P	Programmable -20 to -85 V	120		
	TISP61089A	DR, P	Programmable -20 to -120 V	120		
	TISP61089B	DR	Programmable -20 to -170 V	120		
	TISP61511	DR	Programmable 0 to -85 V	170		
	TISP61512	P	Programmable 0 to -85 V	170		
	TISP61521	DR	Programmable 0 to -170 V	170		
	TISPL7591	DR	Programmable 0 to -80 V	80		
	TISPPBL1	DR, P, SE	Programmable 0 to -90 V	100		
	TISPPBL2	DR, P	Programmable 0 to -90 V	100		
	TISPPBL3	DR	Programmable 0 to -170 V	100		

TISP6NPT2x Series – Programmable Overvoltage Protectors for Dual SLIC Protection

Dual SLIC VOIP applications, with reduced protection cost per line

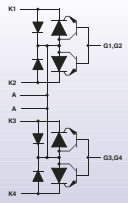
Device	Delivery Options	Standoff Voltage V_{DRM} (V)	Protection Voltage $V_{(BO)}$ (V)	ITSP Ratings for Lightning Surge Standards		
				GR-1089-CORE 2/10 μ s (A)	GR-1089-CORE 10/1000 μ s (A)	ITU-T K20/21 5/310 μ s (A)
	TISP6NTP2A	DR	Programmable 0 to -90 V	85	20	25
	TISP6NTP2C	DR	Programmable 0 to -170 V	90	25	40

TISP83121 – Dual-Gate Unidirectional Overvoltage Protectors for Dual Supply SLIC Protection

\pm ve protection for multiple lines on CO Line Cards

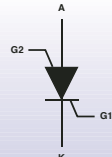
Device	Delivery Options	Standoff Voltage V_{DRM} (V)	Protection Voltage $V_{(BO)}$ (V)	ITSP Ratings for Lightning Surge Standards	
				GR-1089-CORE 10/1000 μ s (A)	ITU-T K20/21 5/310 μ s (A)
	TISP83121	DR	Programmable 0 to \pm 100 V	150	250

TISP820xM Series – Dual Unidirectional Reverse Blocking Programmable Overvoltage Protectors for Dual Supply SLIC Protection

Protection for Infineon PEB4265 and Legerity 79R251 SLICs

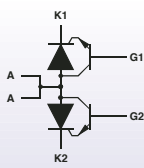
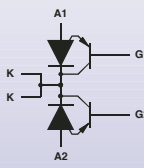
Device	Delivery Options	Standoff Voltage V_{DRM} (V)	Protection Voltage $V_{(BO)}$ (V)	Holding Current I_H (mA)	ITSP Ratings for Lightning Surge Standards		
					GR-1089-CORE 2/10 μ s (A)	GR-1089-CORE 10/1000 μ s (A)	ITU-T K20/21 5/310 μ s (A)
 TISP8200M	DR	Programmable 0 to -90 V	-150	-210	-45	-70	
 TISP8201M	DR	Programmable 0 to +90 V	20	210	45	70	

TISP9110LDM – Integrated Complementary Buffered-Gate SCRs for Dual Polarity SLIC Overvoltage Protection

Integrated ITU-T or GR-1089-CORE intrabuilding protection for Infineon PEB4265 and Legerity 79R251 SLICs

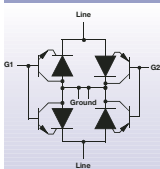
Device	Delivery Options	Standoff Voltage V_{DRM} (V)	Protection Voltage $V_{(BO)}$ (V)	Holding Current I_H (mA)	ITSP Ratings for Lightning Surge Standards		
					GR-1089-CORE 2/10 μ s (A)	GR-1089-CORE 10/1000 μ s (A)	ITU-T K20/21 5/310 μ s (A)
 TISP9110L	DM	Programmable +110 to -110 V	+20, -150	100	30	45	

'EL' Series – Single Bidirectional Primary Overvoltage Protectors for GR-974-CORE Designs

CO Primary Protection – 2EL2, 2EL3, 2EL4

CO Primary Protection for Datalines – 2EL5

High Exposure Station Protector – 2EL6

Device	Delivery Options	Protection Voltage $V_{(BO)}$ (V)	ITSP Ratings for Lightning Surge Standards		
			GR-1089-CORE 2/10 μ s (A)	ITU-T K20/21 5/310 μ s (A)	
	2EL2	Button Cell	265 V to 400 V	100	125
	2EL3	Button Cell	200 V to 265 V	100	125
	2EL4	Button Cell	215 V to 265 V	100	125
	2EL5	Button Cell	65 V to 90 V	100	125
	7EL2	Button Cell	265 V to 400 V	300	400

TISP® Product Dimensions



SMAJ – Plastic Surface Mount Diode

Suffix – AJR

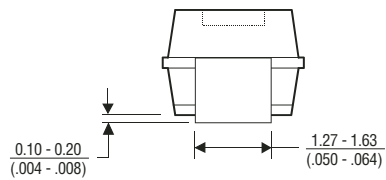
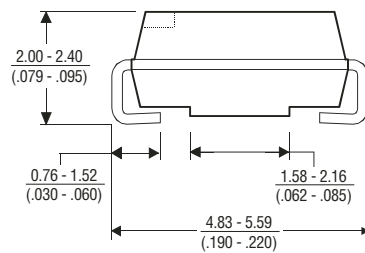
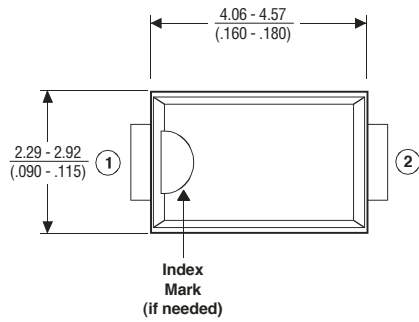

SMBJ – Plastic Surface Mount Diode

Suffix – BJ, BJR

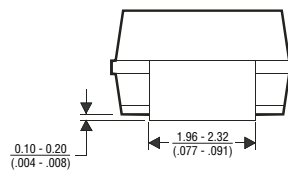
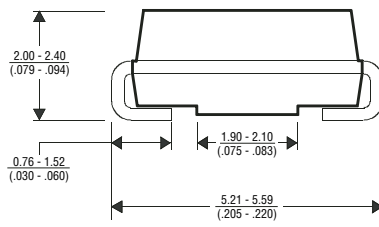
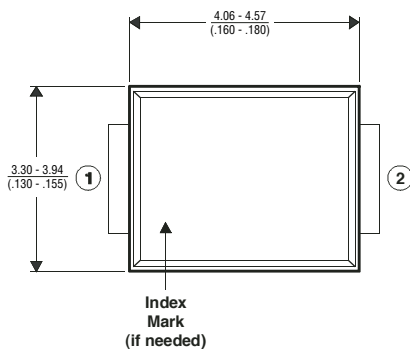

DIMENSIONS = $\frac{\text{MILLIMETERS}}{\text{(INCHES)}}$



SMB03 (Modified D0-214A Package)

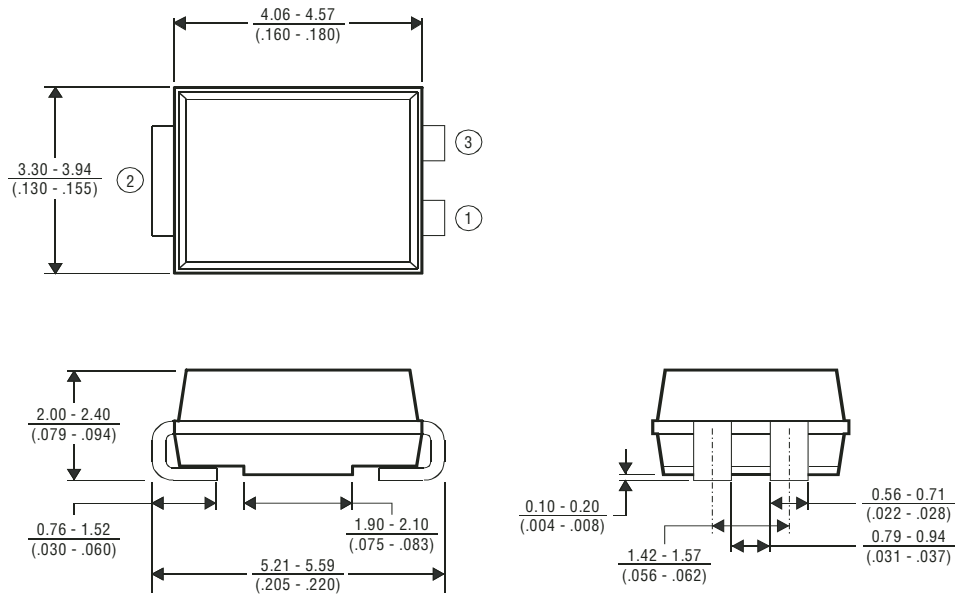

SOIC - Plastic Small Outline

Suffix - D, DR

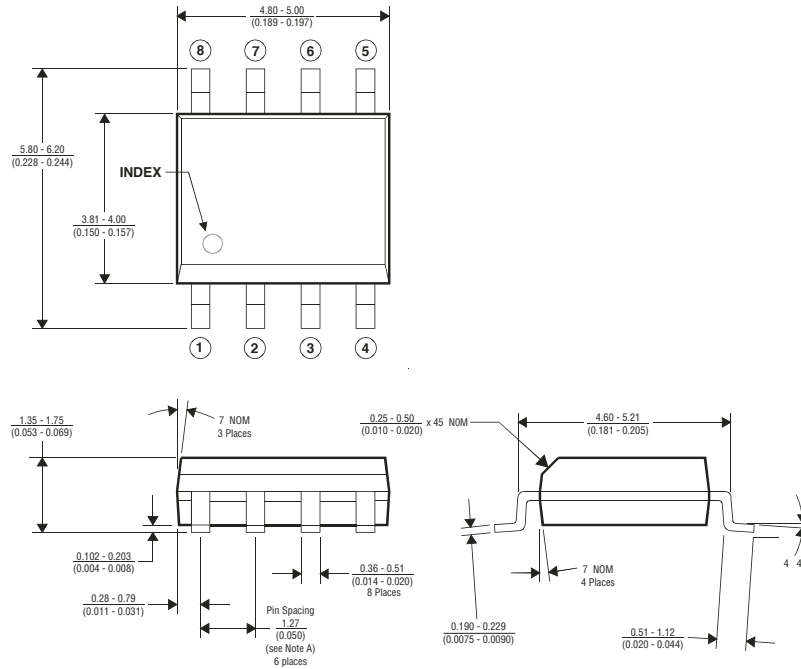

DIMENSIONS = $\frac{\text{MILLIMETERS}}{\text{(INCHES)}}$



SOIC – 8-pin Plastic Small Outline (210 mil)

Suffix – DM

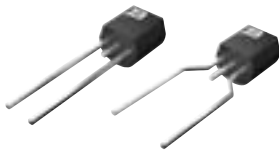
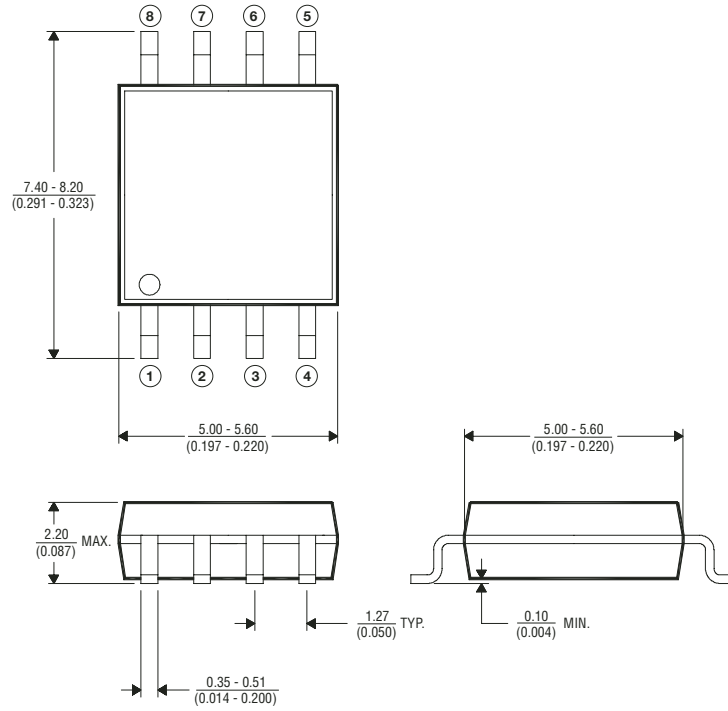

D092 – Cylindrical Plastic

Suffix – LM, LMR, LMFR

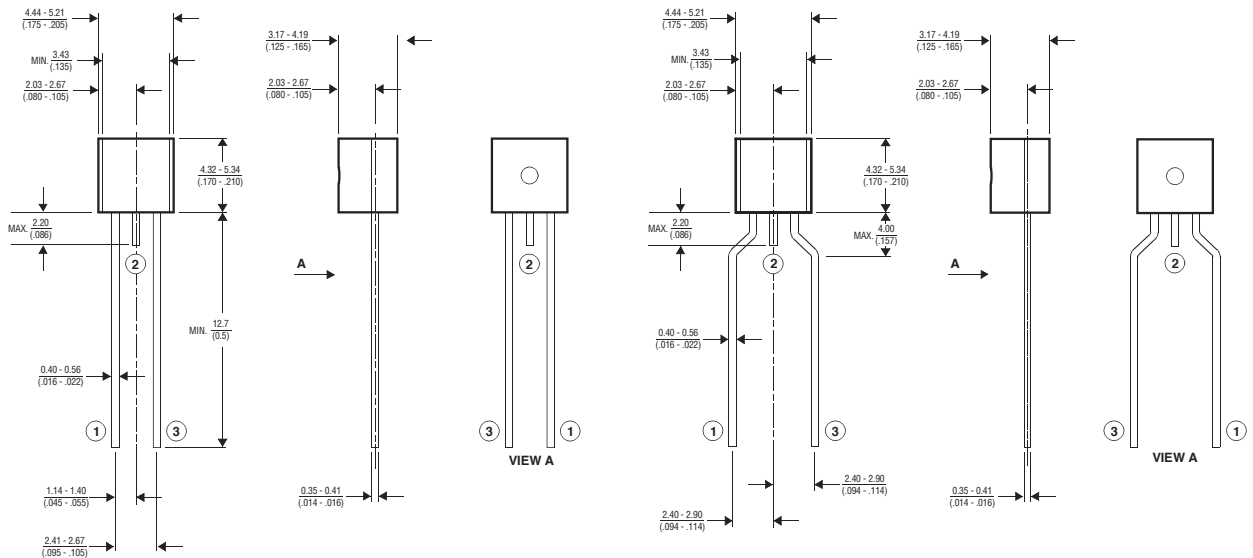

DIMENSIONS = $\frac{\text{MILLIMETERS}}{\text{(INCHES)}}$



SIP – Plastic Single-in-Line

Suffix – SL

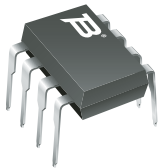
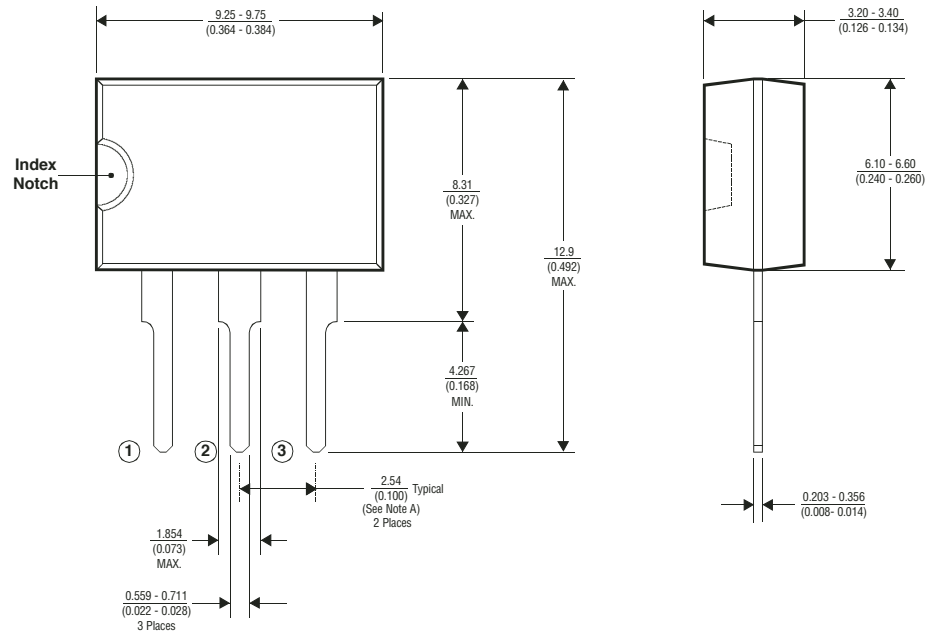

PDIP – Plastic Dual-in-Line

Suffix – P

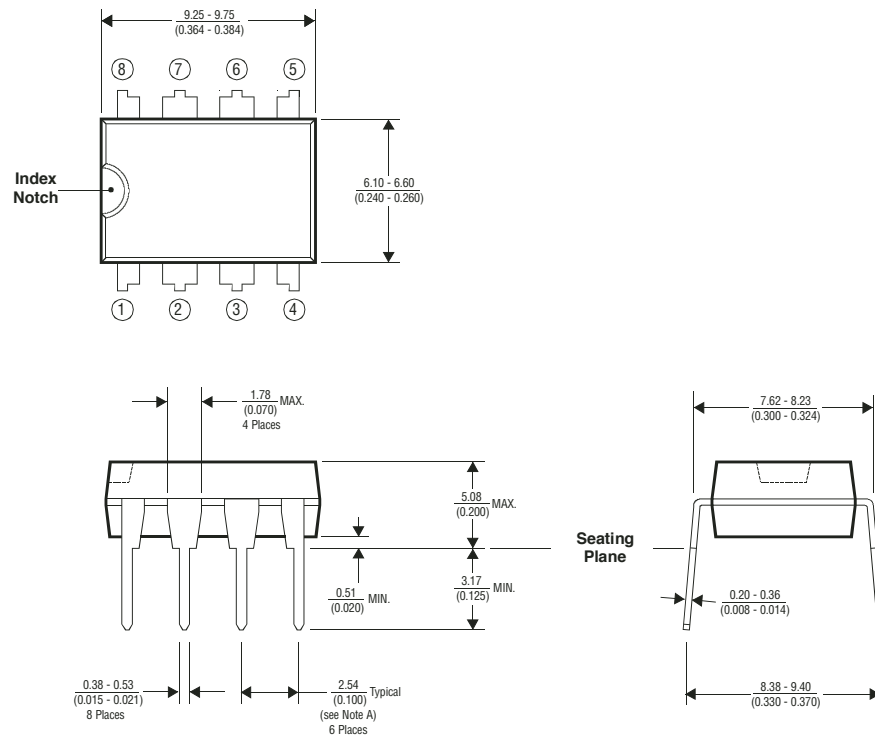

DIMENSIONS = $\frac{\text{MILLIMETERS}}{\text{(INCHES)}}$



9ELX – Primary Protector Series

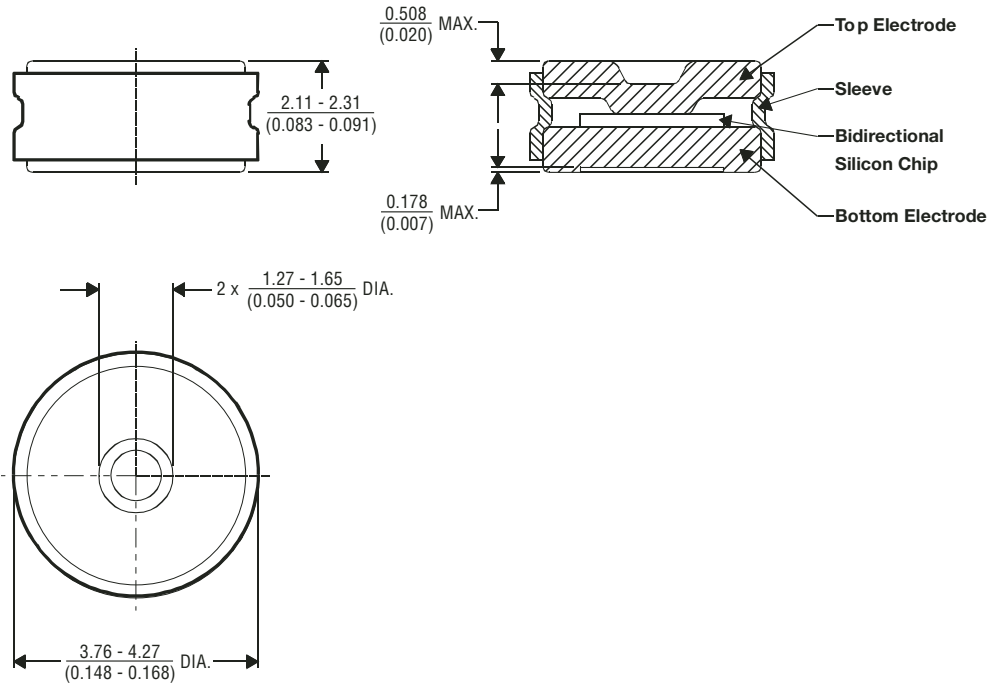

7EL2 – Primary Protector

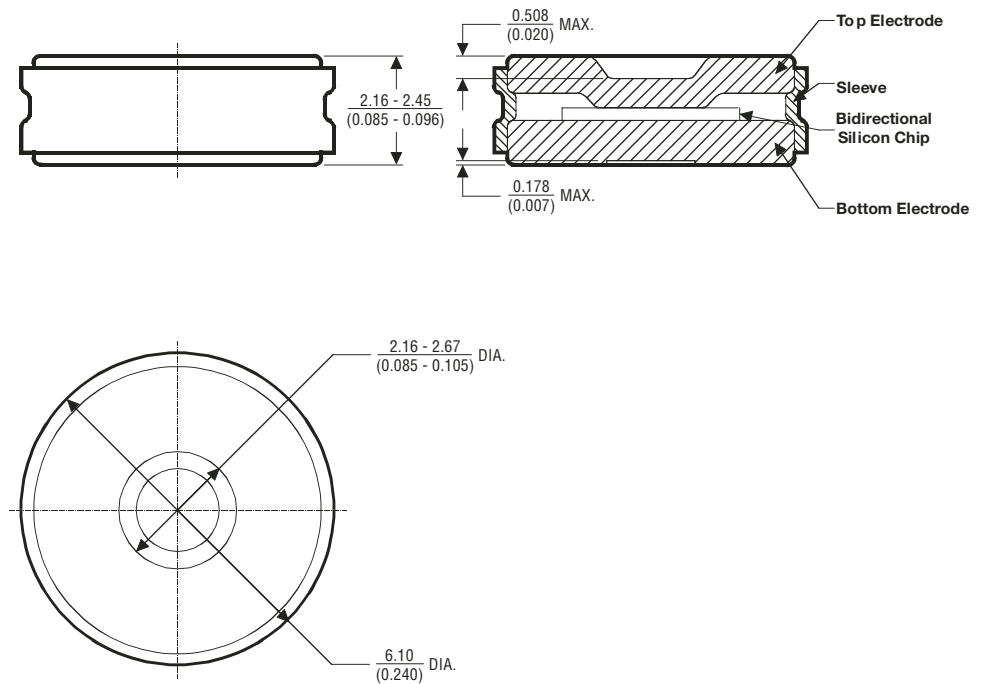

DIMENSIONS = $\frac{\text{MILLIMETERS}}{\text{(INCHES)}}$



Button Cell

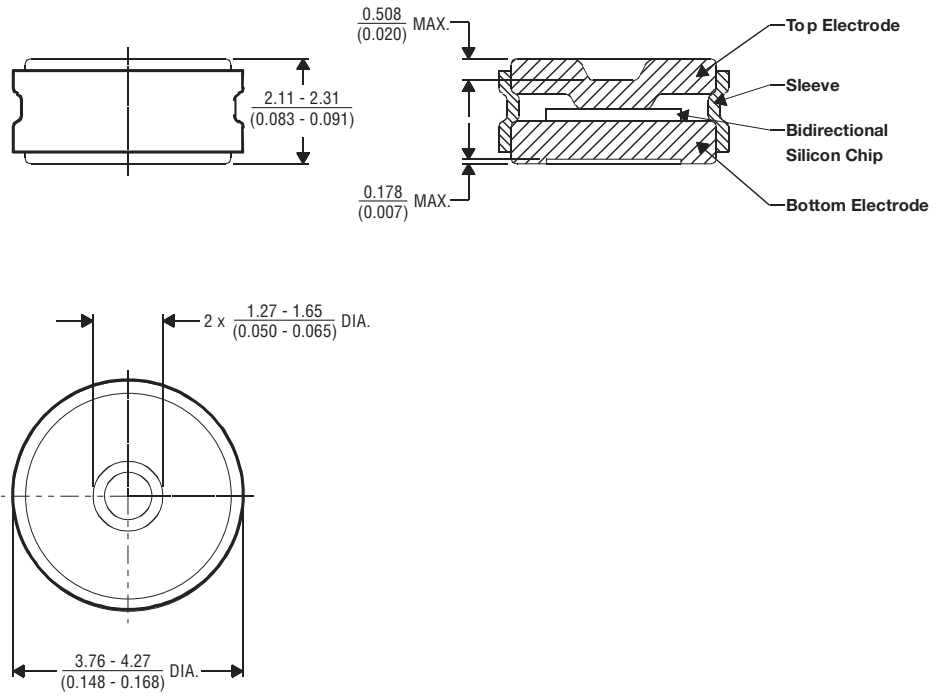

DIMENSIONS = $\frac{\text{MILLIMETERS}}{\text{(INCHES)}}$

TVS Diodes

Selection Guide

Bourns offers Transient Voltage Suppressor diodes for low energy surge and ESD protection applications that meet the following standards: IEC 61000-4-2, IEC 61000-4-4 and IEC 61000-4-5



Features

- Compact package options: DO-214AC (SMA), DO-214AA (SMB) and DO-214AB (SMC)
- Working Peak Reverse Voltages from 5 V up to 170 V
- Breakdown Voltages up to 200 V
- Typical fast response times are less than 1.0 ns (Unidirectional), 5.0 ns (Bidirectional)
- Conforms to JEDEC standards
- Easy to handle on standard pick and place equipment
- Flat configuration minimizes roll away
- RoHS compliance optional

	Minimum Peak Pulse Power Dissipation (TP = 1 ms) P_{PK}	Working Peak Reverse Voltages V_{RWM}	Peak Forward Surge Current 8.3 ms Single Half Sine Wave Superimposed on Rated Load (JEDEC Method)	Package Reference*
CD214A-TX.XX	400 W	5 to 170 V	40 A	SMA
CD214B-TX.XX	600 W	5 to 170 V	100 A	SMB
CD214C-TX.XX	1500 W	5 to 170 V	200 A	SMC

*See data sheet for mechanical specification.

CD214A Series (SMA Package)

Electrical Characteristics (@ T_A = 25 °C unless otherwise noted)

Part Number (Unidirectional Device)	Part Mrkg	Part Number (Bidirectional Device)	Part Mrkg	Breakdown Voltage VBR Volts			Working Peak Reverse Voltage	Max. Reverse Leakage at V _{RWM}	Max. Reverse Voltage at I _{RSM}	Max. Reverse Surge Current	Pkg
				Min.	Max.	@IT (mA)	V _{RWM} (Volts)	I _R (uA)	V _{RSM} (Volts)	I _{RSM} (Amps)	
CD214A-T5.0A	HE	CD214A-T5.0CA	TE	6.40	7.00	10	5.0	800 / 1600	9.2	43.5	SMA
CD214A-T6.0A	HG	CD214A-T6.0CA	TG	6.67	7.37	10	6.0	800 / 1600	10.3	38.8	SMA
CD214A-T6.5A	HK	CD214A-T6.5CA	TK	7.22	7.98	10	6.5	500 / 1000	11.2	35.7	SMA
CD214A-T7.0A	HM	CD214A-T7.0CA	TM	7.78	8.60	10	7.0	200 / 400	12.0	33.3	SMA
CD214A-T7.5A	HP	CD214A-T7.5CA	TP	8.33	9.21	1.0	7.5	100 / 200	12.9	31.0	SMA
CD214A-T8.0A	HR	CD214A-T8.0CA	TR	8.89	9.83	1.0	8.0	50 / 100	13.6	29.4	SMA
CD214A-T8.5A	HT	CD214A-T8.5CA	TT	9.44	10.4	1.0	8.5	10 / 20	14.4	27.7	SMA
CD214A-T9.0A	HV	CD214A-T9.0CA	TV	10.0	11.1	1.0	9.0	5 / 10	15.4	26.0	SMA
CD214A-T10A	HX	CD214A-T10CA	TX	11.1	12.3	1.0	10	5 / 10	17.0	23.5	SMA
CD214A-T11A	HZ	CD214A-T11CA	TZ	12.2	13.2	1.0	11	5.0	18.2	22.0	SMA
CD214A-T12A	IE	CD214A-T12CA	UE	13.3	14.7	1.0	12	5.0	19.9	20.1	SMA
CD214A-T13A	IG	CD214A-T13CA	UG	14.4	15.9	1.0	13	5.0	21.5	18.6	SMA
CD214A-T14A	IK	CD214A-T14CA	UK	15.6	17.2	1.0	14	5.0	23.2	17.2	SMA
CD214A-T15A	IM	CD214A-T15CA	UM	16.7	18.5	1.0	15	5.0	24.4	16.4	SMA
CD214A-T16A	IP	CD214A-T16CA	UP	17.8	19.7	1.0	16	5.0	26.0	15.3	SMA
CD214A-T17A	IR	CD214A-T17CA	UR	18.9	20.9	1.0	17	5.0	27.6	14.5	SMA
CD214A-T18A	IT	CD214A-T18CA	UT	20.0	22.1	1.0	18	5.0	29.2	13.7	SMA
CD214A-T20A	IV	CD214A-T20CA	UV	22.2	24.5	1.0	20	5.0	32.4	12.3	SMA
CD214A-T22A	IX	CD214A-T22CA	UX	24.4	26.9	1.0	22	5.0	35.5	11.2	SMA
CD214A-T24A	IZ	CD214A-T24CA	UZ	26.7	29.5	1.0	24	5.0	38.9	10.3	SMA
CD214A-T26A	JE	CD214A-T26CA	VE	28.9	31.9	1.0	26	5.0	42.1	9.5	SMA
CD214A-T28A	JG	CD214A-T28CA	VG	31.1	34.4	1.0	28	5.0	45.4	8.8	SMA
CD214A-T30A	JK	CD214A-T30CA	VK	33.3	36.8	1.0	30	5.0	48.4	8.3	SMA
CD214A-T33A	JM	CD214A-T33CA	VM	36.7	40.6	1.0	33	5.0	53.3	7.5	SMA
CD214A-T36A	JP	CD214A-T36CA	VP	40	44.2	1.0	36	5.0	58.1	6.9	SMA
CD214A-T40A	JR	CD214A-T40CA	VR	44.4	49.1	1.0	40	5.0	64.5	6.2	SMA
CD214A-T43A	JT	CD214A-T43CA	VT	47.8	52.8	1.0	43	5.0	69.4	5.7	SMA
CD214A-T45A	JV	CD214A-T45CA	VV	50	55.3	1.0	45	5.0	72.7	5.5	SMA
CD214A-T48A	JX	CD214A-T48CA	VX	53.3	58.9	1.0	48	5.0	77.4	5.2	SMA
CD214A-T51A	JZ	CD214A-T51CA	VZ	56.7	62.7	1.0	51	5.0	82.4	4.9	SMA
CD214A-T54A	RE	CD214A-T54CA	WE	60	66.3	1.0	54	5.0	87.1	4.6	SMA
CD214A-T58A	RG	CD214A-T58CA	WG	64.4	71.2	1.0	58	5.0	93.6	4.3	SMA
CD214A-T60A	RK	CD214A-T60CA	WK	66.7	73.7	1.0	60	5.0	96.8	4.1	SMA
CD214A-T64A	RM	CD214A-T64CA	WM	71.1	78.6	1.0	64	5.0	103	3.9	SMA
CD214A-T70A	RP	CD214A-T70CA	WP	77.8	86.0	1.0	70	5.0	113	3.5	SMA
CD214A-T75A	RR	CD214A-T75CA	WR	83.3	92.1	1.0	75	5.0	121	3.3	SMA
CD214A-T78A	RT	CD214A-T78CA	WT	86.7	95.8	1.0	78	5.0	126	3.2	SMA
CD214A-T85A	RV	CD214A-T85CA	WV	94.4	104	1.0	85	5.0	137	2.9	SMA
CD214A-T90A	RX	CD214A-T90CA	WX	100	111	1.0	90	5.0	146	2.7	SMA
CD214A-T100A	RZ	CD214A-T100CA	WZ	111	123	1.0	100	5.0	162	2.5	SMA
CD214A-T110A	SE	CD214A-T110CA	XE	122	135	1.0	110	5.0	177	2.3	SMA
CD214A-T120A	SG	CD214A-T120CA	XG	133	147	1.0	120	5.0	193	2.0	SMA
CD214A-T130A	SK	CD214A-T130CA	XK	144	159	1.0	130	5.0	209	1.9	SMA
CD214A-T150A	SM	CD214A-T150CA	XM	167	185	1.0	150	5.0	243	1.6	SMA
CD214A-T160A	SP	CD214A-T160CA	XP	178	197	1.0	160	5.0	259	1.5	SMA
CD214A-T170A	SR	CD214A-T170CA	XR	189	209	1.0	170	5.0	275	1.4	SMA

Notes:

1. Suffix "A" denotes 5 % tolerance device.
2. Suffix "C" denotes Bidirectional device.
3. Suffix "CA" denotes 5 % tolerance Bidirectional device.
4. 10 % tolerance devices are available but not shown above.
5. For Bidirectional devices having V_R = 10 Volts or under, the I_R limit is double.
6. For Unidirectional devices having V_F Max = 3.5 V at I_F = 35 A, 0.5 Sine Wave of 8.3 ms pulse width.
7. For RoHS compliant devices, add suffix "LF" to part number.

CD214B Series (SMB Package)

Electrical Characteristics (@ T_A = 25 °C unless otherwise noted)

Part Number (Unidirectional Device)	Part Mrkg	Part Number (Bidirectional Device)	Part Mrkg	Breakdown Voltage VBR Volts			Working Peak Reverse Voltage	Max. Reverse Leakage at V _{RWM}	Max. Reverse Voltage at I _{RSM}	Max. Reverse Surge Current	Pkg
				Min.	Max.	@IT (mA)	V _{RWM} (Volts)	I _R (uA)	V _{RSM} (Volts)	I _{RSM} (Amps)	
CD214B-T5.0A	HKE	CD214B-T5.0CA	AE	6.40	7.25	10	5.0	800	9.2	65.2	SMB
CD214B-T6.0A	KG	CD214B-T6.0CA	AG	6.67	7.67	10	6.0	800	10.3	58.3	SMB
CD214B-T6.5A	KK	CD214B-T6.5CA	AK	7.22	8.30	10	6.5	500	11.2	53.6	SMB
CD214B-T7.0A	KM	CD214B-T7.0CA	AM	7.78	8.95	10	7.0	200	12.0	50.0	SMB
CD214B-T7.5A	KP	CD214B-T7.5CA	AP	8.33	9.58	1.0	7.5	100	12.9	46.5	SMB
CD214B-T8.0A	KR	CD214B-T8.0CA	AR	8.89	10.2	1.0	8.0	50	13.6	44.1	SMB
CD214B-T8.5A	KT	CD214B-T8.5CA	AT	9.44	10.8	1.0	8.5	20	14.4	41.7	SMB
CD214B-T9.0A	KV	CD214B-T9.0CA	AV	10.0	11.5	1.0	9.0	10	15.4	39.0	SMB
CD214B-T10A	KX	CD214B-T10CA	AX	11.1	12.8	1.0	10	5.0	17.0	35.3	SMB
CD214B-T11A	KZ	CD214B-T11CA	AZ	12.2	14.4	1.0	11	5.0	18.2	33.0	SMB
CD214B-T12A	LE	CD214B-T12CA	BE	13.3	15.3	1.0	12	5.0	19.9	30.2	SMB
CD214B-T13A	LG	CD214B-T13CA	BG	14.4	16.5	1.0	13	5.0	21.5	27.9	SMB
CD214B-T14A	LK	CD214B-T14CA	BK	15.6	17.9	1.0	14	5.0	23.2	25.8	SMB
CD214B-T15A	LM	CD214B-T15CA	BM	16.7	19.2	1.0	15	5.0	24.4	24.0	SMB
CD214B-T16A	LP	CD214B-T16CA	BP	17.8	20.5	1.0	16	5.0	26.0	23.1	SMB
CD214B-T17A	LR	CD214B-T17CA	BR	18.9	21.7	1.0	17	5.0	27.6	21.7	SMB
CD214B-T18A	LT	CD214B-T18CA	BT	20.0	23.3	1.0	18	5.0	29.2	20.5	SMB
CD214B-T20A	LV	CD214B-T20CA	BV	22.2	25.5	1.0	20	5.0	32.4	18.5	SMB
CD214B-T22A	LX	CD214B-T22CA	BX	24.4	28.0	1.0	22	5.0	35.5	16.9	SMB
CD214B-T24A	LZ	CD214B-T24CA	BZ	26.7	30.7	1.0	24	5.0	38.9	15.4	SMB
CD214B-T26A	ME	CD214B-T26CA	CE	28.9	32.2	1.0	26	5.0	42.1	14.2	SMB
CD214B-T28A	MG	CD214B-T28CA	CG	31.1	35.8	1.0	28	5.0	45.4	13.2	SMB
CD214B-T30A	MK	CD214B-T30CA	CK	33.3	38.3	1.0	30	5.0	48.4	12.4	SMB
CD214B-T33A	MM	CD214B-T33CA	CM	36.7	42.2	1.0	33	5.0	53.3	11.3	SMB
CD214B-T36A	MP	CD214B-T36CA	CP	40	46.0	1.0	36	5.0	58.1	10.3	SMB
CD214B-T40A	MR	CD214B-T40CA	CR	44.4	51.1	1.0	40	5.0	64.5	9.3	SMB
CD214B-T43A	MT	CD214B-T43CA	CT	47.8	54.9	1.0	43	5.0	69.4	8.6	SMB
CD214B-T45A	MV	CD214B-T45CA	CV	50	57.5	1.0	45	5.0	72.7	8.3	SMB
CD214B-T48A	MX	CD214B-T48CA	CX	53.3	61.3	1.0	48	5.0	77.4	7.7	SMB
CD214B-T51A	MZ	CD214B-T51CA	CZ	56.7	65.2	1.0	51	5.0	82.4	7.3	SMB
CD214B-T54A	NE	CD214B-T54CA	DE	60	69	1.0	54	5.0	87.1	6.9	SMB
CD214B-T58A	NG	CD214B-T58CA	DG	64.4	74.6	1.0	58	5.0	93.6	6.4	SMB
CD214B-T60A	NK	CD214B-T60CA	DK	66.7	76.7	1.0	60	5.0	96.8	6.2	SMB
CD214B-T64A	NM	CD214B-T64CA	DM	71.1	81.8	1.0	64	5.0	103	5.8	SMB
CD214B-T70A	NP	CD214B-T70CA	DP	77.8	89.5	1.0	70	5.0	113	5.3	SMB
CD214B-T75A	NR	CD214B-T75CA	DR	83.3	95.8	1.0	75	5.0	121	4.9	SMB
CD214B-T78A	NT	CD214B-T78CA	DT	86.7	99.7	1.0	78	5.0	126	4.7	SMB
CD214B-T85A	NV	CD214B-T85CA	DV	94.4	109	1.0	85	5.0	137	4.4	SMB
CD214B-T90A	NX	CD214B-T90CA	DX	100	116	1.0	90	5.0	146	4.1	SMB
CD214B-T100A	NZ	CD214B-T100CA	DZ	111	128	1.0	100	5.0	162	3.7	SMB
CD214B-T110A	PE	CD214B-T110CA	EE	122	140	1.0	110	5.0	177	3.4	SMB
CD214B-T120A	PG	CD214B-T120CA	EG	133	153	1.0	120	5.0	193	3.1	SMB
CD214B-T130A	PK	CD214B-T130CA	EK	144	165	1.0	130	5.0	209	2.9	SMB
CD214B-T150A	PM	CD214B-T150CA	EM	167	192	1.0	150	5.0	243	2.5	SMB
CD214B-T160A	PP	CD214B-T160CA	EP	178	205	1.0	160	5.0	259	2.3	SMB
CD214B-T170A	PR	CD214B-T170CA	ER	189	218	1.0	170	5.0	275	2.2	SMB

Notes:

1. Suffix "A" denotes 5 % tolerance device.
2. Suffix "C" denotes Bidirectional device.
3. Suffix "CA" denotes 5 % tolerance Bidirectional device.
4. 10 % tolerance devices are available but not shown above.
5. For Bidirectional devices having V_R = 10 Volts or under, the I_R limit is double.
6. For Unidirectional devices having V_F Max = 3.5 V at I_F = 35 A, 0.5 Sine Wave of 8.3 ms pulse width.
7. For RoHS compliant devices, add suffix "LF" to part number.

CD214C Series (SMC Package)

Electrical Characteristics (@ T_A = 25 °C unless otherwise noted)

Part Number (Unidirectional Device)	Part Mrkg	Part Number (Bidirectional Device)	Part Mrkg	Breakdown Voltage VBR Volts			Working Peak Reverse Voltage	Max. Reverse Leakage at V _{RWM}	Max. Reverse Voltage at I _{RSM}	Max. Reverse Surge Current	Pkg
				Min.	Max.	@IT (mA)	V _{RWM} (Volts)	I _r (uA)	V _{RSM} (Volts)	I _{RSM} (Amps)	
CD214C-T5.0A	GDE	CD214C-T5.0CA	BDE	6.40	7.23	10	5.0	1000	9.2	163	SMC
CD214C-T6.0A	GDG	CD214C-T6.0CA	BDG	6.67	7.67	10	6.0	1000	10.3	145.6	SMC
CD214C-T6.5A	GDK	CD214C-T6.5CA	BDK	7.22	8.3	10	6.5	500	11.2	133.9	SMC
CD214C-T7.0A	GDM	CD214C-T7.0CA	BDM	7.78	8.95	10	7.0	200	12.0	125	SMC
CD214C-T7.5A	GDP	CD214C-T7.5CA	BDP	8.33	9.58	1.0	7.5	100	12.9	116.3	SMC
CD214C-T8.0A	GDR	CD214C-T8.0CA	BDR	8.89	10.2	1.0	8.0	50	13.6	110.3	SMC
CD214C-T8.5A	GDT	CD214C-T8.5CA	BDT	9.44	10.8	1.0	8.5	20	14.4	104.2	SMC
CD214C-T9.0A	GDV	CD214C-T9.0CA	BDV	10.0	11.5	1.0	9.0	10	15.4	97.4	SMC
CD214C-T10A	GDX	CD214C-T10CA	BDX	11.1	12.8	1.0	10	5.0	17.0	88.2	SMC
CD214C-T11A	GDZ	CD214C-T11CA	BDZ	12.2	14.4	1.0	11	5.0	18.2	82.4	SMC
CD214C-T12A	GEE	CD214C-T12CA	BEE	13.3	15.3	1.0	12	5.0	19.9	75.3	SMC
CD214C-T13A	GEG	CD214C-T13CA	BEG	14.4	16.5	1.0	13	5.0	21.5	69.7	SMC
CD214C-T14A	GEK	CD214C-T14CA	BEK	15.6	17.9	1.0	14	5.0	23.2	64.7	SMC
CD214C-T15A	GEM	CD214C-T15CA	BEM	16.7	19.2	1.0	15	5.0	24.4	61.5	SMC
CD214C-T16A	GEP	CD214C-T16CA	BEP	17.8	20.5	1.0	16	5.0	26.0	57.7	SMC
CD214C-T17A	GER	CD214C-T17CA	BER	18.9	21.7	1.0	17	5.0	27.6	53.3	SMC
CD214C-T18A	GET	CD214C-T18CA	BET	20.0	23.3	1.0	18	5.0	29.2	51.4	SMC
CD214C-T20A	GEV	CD214C-T20CA	BEV	22.2	25.5	1.0	20	5.0	32.4	46.3	SMC
CD214C-T22A	GEX	CD214C-T22CA	BEX	24.4	28	1.0	22	5.0	35.5	42.2	SMC
CD214C-T24A	GEZ	CD214C-T24CA	BEZ	26.7	30.7	1.0	24	5.0	38.9	38.6	SMC
CD214C-T26A	GFE	CD214C-T26CA	BFE	28.9	32.2	1.0	26	5.0	42.1	35.6	SMC
CD214C-T28A	GFG	CD214C-T28CA	BFG	31.1	35.8	1.0	28	5.0	45.4	33	SMC
CD214C-T30A	GFK	CD214C-T30CA	BFK	33.3	38.3	1.0	30	5.0	48.4	31	SMC
CD214C-T33A	GFM	CD214C-T33CA	BFM	36.7	42.2	1.0	33	5.0	53.3	28.1	SMC
CD214C-T36A	GFP	CD214C-T36CA	BFP	40	46	1.0	36	5.0	58.1	25.8	SMC
CD214C-T40A	GFR	CD214C-T40CA	BFR	44.4	51.1	1.0	40	5.0	64.5	23.3	SMC
CD214C-T43A	GFT	CD214C-T43CA	BFT	47.8	54.9	1.0	43	5.0	69.4	21.6	SMC
CD214C-T45A	GFV	CD214C-T45CA	BFV	50	57.5	1.0	45	5.0	72.7	20.6	SMC
CD214C-T48A	GFX	CD214C-T48CA	BFX	53.3	61.3	1.0	48	5.0	77.4	19.4	SMC
CD214C-T51A	GFZ	CD214C-T51CA	BFZ	56.7	65.2	1.0	51	5.0	82.4	18.2	SMC
CD214C-T54A	GGE	CD214C-T54CA	BGE	60	69	1.0	54	5.0	87.1	17.2	SMC
CD214C-T58A	GGG	CD214C-T58CA	BGG	64.4	74.6	1.0	58	5.0	93.6	16	SMC
CD214C-T60A	GGK	CD214C-T60CA	BGK	66.7	76.7	1.0	60	5.0	96.8	15.5	SMC
CD214C-T64A	GGM	CD214C-T64CA	BGM	71.1	81.8	1.0	64	5.0	103	14.6	SMC
CD214C-T70A	GGP	CD214C-T70CA	BGP	77.8	89.5	1.0	70	5.0	113	13.3	SMC
CD214C-T75A	GGR	CD214C-T75CA	BGR	83.3	95.8	1.0	75	5.0	121	12.4	SMC
CD214C-T78A	GGT	CD214C-T78CA	BGT	86.7	99.7	1.0	78	5.0	126	11.4	SMC
CD214C-T85A	GGV	CD214C-T85CA	BGV	94.4	108.2	1.0	85	5.0	137	10.4	SMC
CD214C-T90A	GGX	CD214C-T90CA	BGX	100	115.5	1.0	90	5.0	146	10.3	SMC
CD214C-T100A	GGZ	CD214C-T100CA	BGZ	111	128	1.0	100	5.0	162	9.3	SMC
CD214C-T110A	GHE	CD214C-T110CA	BHE	122	140	1.0	110	5.0	177	8.4	SMC
CD214C-T120A	GHG	CD214C-T120CA	BHG	133	153	1.0	120	5.0	193	7.9	SMC
CD214C-T130A	GHK	CD214C-T130CA	BHK	144	165	1.0	130	5.0	209	7.2	SMC
CD214C-T150A	GHM	CD214C-T150CA	BHM	167	192	1.0	150	5.0	243	6.2	SMC
CD214C-T160A	GHP	CD214C-T160CA	BHP	178	205	1.0	160	5.0	259	5.8	SMC
CD214C-T170A	GHR	CD214C-T170CA	BHR	189	217.5	1.0	170	5.0	275	5.5	SMC

Notes:

1. Suffix "A" denotes 5 % tolerance device.
2. Suffix "C" denotes Bidirectional device.
3. Suffix "CA" denotes 5 % tolerance Bidirectional device.
4. 10 % tolerance devices are available but not shown above.
5. For Bidirectional devices having V_R = 10 Volts or under, the I_R limit is double.
6. For Unidirectional devices having V_F Max = 3.5 V at I_F = 35 A, 0.5 Sine Wave of 8.3 ms pulse width.
7. For RoHS compliant devices, add suffix "LF" to part number.

Bourns® Multifuse® Resettable Fuses

Selection Guide

The range of Bourns® Multifuse® Polymer PTC resettable fuses is designed to limit overcurrents in telecommunications equipment as well as many other types of equipment. Adequate overcurrent protection is needed to allow equipment to comply with international standards. Overcurrents can be caused by AC power or lightning flash disturbances that are induced or conducted to the telephone line. Our extensive range offers multiple voltage variants to suit specific application requirements.

Features

- Resettable Circuit Protection
- Designed to Withstand Lightning Surge

- Designed to Withstand AC Power Cross
- Available in Matched Resistance “Bins”
- Agency Approvals - UL, CSA, TÜV
- Popular Footprints and Packaging
- Low Resistance
- Lead Free Options
- Custom Designs Available
- Package Types: SM, R, Disk, Strap

Applications

- CPE and Central Office
- Access Equipment
- Hybrid-Fiber Coax
- Power over Ethernet

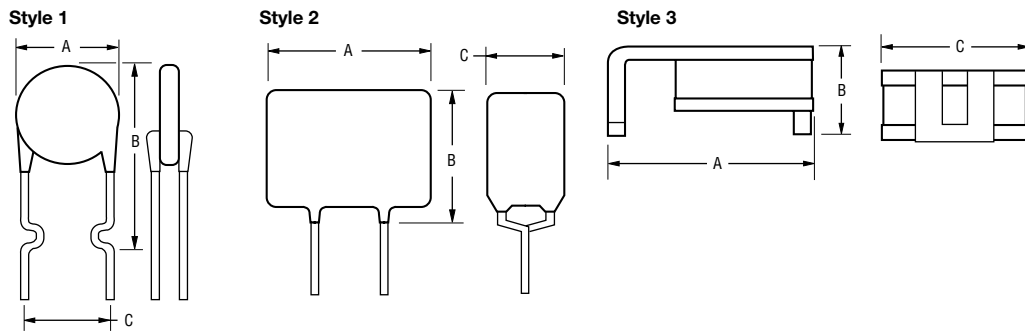

MF-R/90 Series – Radial Leaded, 90 Volts

Typical Applications: Hybrid-fiber coax, power passing taps, Power over Ethernet

RoHS Compliant

Model	I _{hold} (Amps @ 23 °C)	V max. (Volts)	I max. (Amps)	Initial Resistance (Ohms @ 23 °C Min.)	1 Hour (R1) Post-Trip Resistance (Ohms @ 23 °C Max.)	Dimensions [mm/(in)]			Style
						A Max.	B Max.	C Nom.	
 MF-R055/90 MF-R055/90U MF-R075/90	0.55	90	10	0.45	2.0	10.9 (0.43)	14.0 (0.55)	5.1 (0.201)	1
	0.55			0.45	2.0	10.3 (0.4)	10.3 (0.4)		
	0.75			0.37	1.65	11.9 (0.47)	15.5 (0.61)		

MF-SM013/250 Series – Surface Mount, 60 Volts, 250 Vrms Short Duration Interrupt

Applicable Standards: ITU-T K.20/21/45, GR-1089-CORE IntraBuilding

RoHS Compliant

Model	Ihold (Amps @ 23 °C)	V max. (Volts)	I max. (Amps)	Max. Interrupt Ratings		Initial Resistance (Ohms @ 23 °C Min.)	1 Hour (R1) Post-Trip Resistance (Ohms @ 23 °C Max.)	Dimensions [mm/(in)]			Style
				Volts (Vrms)	Amps (A)			A Max.	B Max.	C Nom.	
 MF-SM013/250-2	0.13	60	3.0	250	3	6.5	20.0	9.4 (0.370)	3.4 (0.133)	7.4 (0.291)	3
MF-SM013/250-A-2											
MF-SM013/250-B-2											
MF-SM013/250-C-2											

MF-RX/250 Series – Radial Leaded, 60 Volts, 250 Vrms Short Duration Interrupt

Fast Trip, Small Package. Applicable Standards: ITU-T K.20/21/45, GR-1089-CORE IntraBuilding RoHS Compliant

Model	Ihold (Amps @ 23 °C)	V max. (Volts)	I max. (Amps)	Max. Interrupt Ratings		Initial Resistance (Ohms @ 23 °C Min.)	1 Hour (R1) Post-Trip Resistance (Ohms @ 23 °C Max.)	Dimensions [mm/(in)]			Style
				Volts (Vrms)	Amps (A)			A Max.	B Max.	C Nom.	
 MF-RX012/250	0.12	60	3.0	250	3	4.0	16.0	6.5 (0.256)	11.0 (0.433)	5.1 (0.201)	2
MF-RX012/250-A	0.12		3.0		3	7.0	16.0	6.5 (0.256)	11.0 (0.433)		
MF-RX012/250-C	0.12		3.0		3	5.5	14.0	6.5 (0.256)	11.0 (0.433)		
MF-RX012/250-F	0.12		3.0		3	6.0	16.0	6.5 (0.256)	11.0 (0.433)		
MF-RX012/250-1	0.12		3.0		3	6.0	16.0	6.5 (0.256)	11.0 (0.433)		
MF-RX012/250-2	0.12		3.0		3	8.0	16.0	6.5 (0.256)	11.0 (0.433)		
MF-RX012/250-T	0.12		3.0		3	7.0	16.0	6.5 (0.256)	11.0 (0.433)		
MF-RX012/250U	0.12		3.0		3	6.0	16.0	6.0 (0.236)	10.0 (0.394)		
MF-RX014/250	0.145		3.0		3	3.0	14.0	6.5 (0.256)	11.0 (0.433)		
MF-RX014/250-A	0.145		3.0		3	3.0	12.0	6.5 (0.256)	11.0 (0.433)		
MF-RX014/250-B	0.145		3.0		3	4.5	14.0	6.5 (0.256)	11.0 (0.433)		
MF-RX014/250-T	0.145		3.0		3	5.4	14.0	6.5 (0.256)	11.0 (0.433)		
MF-RX014/250U	0.145		3.0		3	3.5	12.0	6.0 (0.236)	10.0 (0.394)		
MF-RX018/250	0.18		10.0		10	0.8	4.0	11.0 (0.433)	13.6 (0.535)		
MF-RX018/250U	0.18		10.0		10	0.8	4.0	10.4 (0.409)	12.6 (0.496)		

MF-R/600 Series – Radial Leaded, 60 Volts, 600 Vrms Short Duration Interrupt

Applicable Standards: UL60950, GR-1089-CORE, ITU-T K.20/21/45

RoHS Compliant

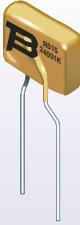
Model	Ihold (Amps @ 23 °C)	V max. (Volts)	I max. (Amps)	Max. Interrupt Ratings		Initial Resistance (Ohms @ 23 °C Min.)	1 Hour (R1) Post-Trip Resistance (Ohms @ 23 °C Max.)	Dimensions [mm/(in)]			Style
				Volts (Vrms)	Amps (A)			A Max.	B Max.	C Nom.	
 MF-R015/600	0.15	60	3.0	600	3	6.0	22.0	13.5 (0.531)	12.6 (0.496)	6.0 (0.236)	2
MF-R015/600-A	0.15					7.0	20.0	13.5 (0.531)			
MF-R015/600-B	0.15					9.0	22.0	13.5 (0.531)			
MF-R015/600-F	0.15					7.0	22.0	13.5 (0.531)			
MF-R016/600	0.16					4.0	18.0	16.0 (0.629)			
MF-R016/600-A	0.16					4.0	16.0	16.0 (0.629)			
MF-R016/600-1	0.16					4.0	17.0	16.0 (0.629)			

Device Options:

- Coated or Uncoated
- Un-Tripped or Pre-Tripped
- Narrow Resistance Bands
- Custom Specified Resistance Bands
- Resistance Sort to 0.5 Ohm Bins
- Disks With and Without Solder Coating

Packaging Options:

- Bulk Packed
- Tape and Reel
- Custom Lead Lengths

Selection of Surface Mount Low Voltage Products

Features

- Industry Standard Sizes
- Resettable Circuit Protection
- Agency Approvals - UL, CSA, TÜV.
- Popular Footprints and Packaging
- Low Resistance
- Lead Free Options
- Custom Designs Available

Applications

- Computers and Peripherals
- General Electronics
- Automotive
- Set-top Boxes
- Servers & Routers

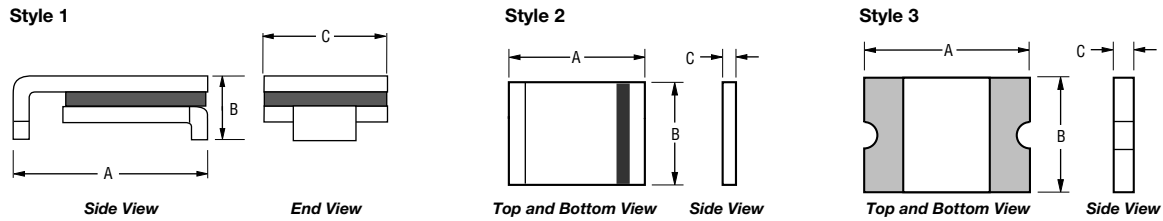

MF-SMDF Series – Surface Mount (Lead Free), 10-60 Volts

2018 Package. Typical Application: Power over Ethernet. Applicable Standard: IEEE 802.3AF.

RoHS Compliant

Model	I _{hold} (Amps @ 23 °C)	V max. (Volts)	I max. (Amps)	Initial Resistance (Ohms @ 23 °C Min.)	1 Hour (R1) Post-Trip Resistance (Ohms @ 23 °C Max.)	Dimensions [mm/(in)]			Style
						A Max.	B Max.	C Nom.	
 MF-SMDF050	0.50	60	10	0.20	0.95	5.44 (0.214)	4.93 (0.194)	1.09 (0.043)	3
	MF-SMDF150	1.50	15	40	0.07			0.175	

MF-SM Series – Surface Mount, 15-33 Volts

3425 Package. Typical Application: Circuit Level Protection.

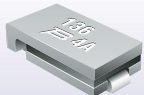
Model	I _{hold} (Amps @ 23 °C)	V max. (Volts)	I max. (Amps)	Initial Resistance (Ohms @ 23 °C Min.)	1 Hour (R1) Post-Trip Resistance (Ohms @ 23 °C Max.)	Dimensions [mm/(in)]			Style	
						A Max.	B Max.	C Nom.		
 MF-SM150	1.50	15	100	0.06	0.25	9.50 (0.374)	3.00 (0.118)	6.71 (0.264)	1	
	MF-SM150/33	1.50	33	40	0.06					0.23
	MF-SM200	2.00	15	100	0.045					0.125
	MF-SM250	2.50	15	100	0.024					0.085

Note:

RoHS compliant by adding -99 at the end of the part number, i.e. MF-SM150-2-99.

MF-SM Series – Surface Mount, 6-60 Volts

2920 Package. Typical Application: Circuit Level Protection.

Model	I _{hold} (Amps @ 23 °C)	V max. (Volts)	I max. (Amps)	Initial Resistance (Ohms @ 23 °C Min.)	1 Hour (R1) Post-Trip Resistance (Ohms @ 23 °C Max.)	Dimensions [mm/(in)]			Style
						A Max.	B Max.	C Nom.	
 MF-SM030	0.30	60	40	0.90	4.80	7.98 (0.314)	3.18 (0.125)	5.44 (0.214)	1
MF-SM050	0.50	60	40	0.35	1.40				
MF-SM075	0.75	30	80	0.23	1.00				
MF-SM100	1.10	30	80	0.12	0.48				
MF-SM100/33	1.10	33	40	0.12	0.41				
MF-SM125	1.25	15	100	0.07	0.25				
MF-SM260	2.60	6	100	0.025	0.075				

Note:

RoHS compliant by adding -99 at the end of the part number.

MF-MSMF Series – Surface Mount (Lead Free), 6-60 Volts

1812 Package. Typical Application: USB 2.0.

RoHS Compliant

Model	I _{hold} (Amps @ 23 °C)	V max. (Volts)	I max. (Amps)	Initial Resistance (Ohms @ 23 °C Min.)	1 Hour (R1) Post-Trip Resistance (Ohms @ 23 °C Max.)	Dimensions [mm/(in)]			Style
						A Max.	B Max.	C Nom.	
 MF-MSMF010	0.10	60	40	0.70	15.0	4.73 (0.186)	3.41 (0.134)	1.10 (0.043)	3
MF-MSMF014	0.14	60	40	0.40	6.50				
MF-MSMF020	0.20	30	80	0.40	6.00				
MF-MSMF030	0.30	30	10	0.30	3.00				
MF-MSMF050	0.50	15	100	0.15	1.00				
MF-MSMF075	0.75	13.2	100	0.11	0.45				
MF-MSMF075/24	0.75	24	40	0.11	0.45				
MF-MSMF110	1.10	6	100	0.04	0.21				
MF-MSMF110/16	1.10	16	100	0.04	0.21				
MF-MSMF125	1.25	6	100	0.035	0.14				
MF-MSMF150	1.50	6	100	0.03	0.12				
MF-MSMF160	1.60	8	100	0.035	0.099				
MF-MSMF200	2.00	6	100	0.020	0.1				
MF-MSMF250/16	2.50	16	100	0.015	0.1				
MF-MSMF260	2.60	6	100	0.015	0.08				

MF-MSMD Series – Surface Mount, 6-60 Volts

1812 Package. Typical Application: USB 2.0.

Model	Ihold (Amps @ 23 °C)	V max. (Volts)	I max. (Amps)	Initial Resistance (Ohms @ 23 °C Min.)	1 Hour (R1) Post-Trip Resistance (Ohms @ 23 °C Max.)	Dimensions [mm/(in)]			Style
						A Max.	B Max.	C Nom.	
 MF-MSMD010	0.10	60	40	0.70	15.000	4.73 (0.186)	3.41 (0.134)	0.81 (0.032)	2
MF-MSMD014	0.14	60	40	0.40	6.500			0.81 (0.032)	
MF-MSMD020	0.20	30	80	0.40	6.000			0.81 (0.032)	
MF-MSMD030	0.30	30	10	0.30	3.000			0.81 (0.032)	
MF-MSMD050	0.50	15	100	0.15	1.000			0.62 (0.024)	
MF-MSMD075	0.75	13.2	100	0.11	0.450			0.62 (0.024)	
MF-MSMD110	1.10	6	100	0.04	0.210			0.62 (0.024)	
MF-MSMD125	1.25	6	100	0.035	0.140			0.48 (0.019)	
MF-MSMD150	1.50	6	100	0.03	0.120			0.48 (0.019)	
MF-MSMD160	1.60	8	100	0.035	0.099			0.48 (0.019)	
MF-MSMD200	2.00	6	100	0.020	0.100			0.48 (0.019)	
MF-MSMD260	2.60	6	100	0.015	0.080			0.48 (0.019)	

MF-USMD Series – Surface Mount, 6-30 Volts

1210 Package. Typical Application: USB 2.0.

Model	Ihold (Amps @ 23 °C)	V max. (Volts)	I max. (Amps)	Initial Resistance (Ohms @ 23 °C Min.)	1 Hour (R1) Post-Trip Resistance (Ohms @ 23 °C Max.)	Dimensions [mm/(in)]			Style
						A Max.	B Max.	C Nom.	
 MF-USMD005	0.05	30	10	2.80	50.0	3.43 (0.135)	2.80 (0.110)	0.85 (0.033)	2
MF-USMD010	0.10	30	10	0.80	15.0			0.85 (0.033)	
MF-USMD020	0.20	30	10	0.40	5.00			0.85 (0.033)	
MF-USMD035	0.35	6	40	0.20	1.30			0.62 (0.024)	
MF-USMD050	0.50	13.2	40	0.18	0.90			0.62 (0.024)	
MF-USMD075	0.75	6	40	0.07	0.45			0.62 (0.024)	
MF-USMD110	1.10	6	40	0.05	0.21			0.48 (0.019)	

MF-NSMF Series – Surface Mount (Lead Free), 6-30 Volts

1206 Package. Typical Application: USB On The Go

RoHS Compliant

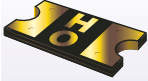
Model	I _{hold} (Amps @ 23 °C)	V max. (Volts)	I max. (Amps)	Initial Resistance (Ohms @ 23 °C Min.)	1 Hour (R1) Post-Trip Resistance (Ohms @ 23 °C Max.)	Dimensions [mm/(in)]			Style	
						A Max.	B Max.	C Nom.		
	MF-NSMF012	0.12	30	10	1.50	6.0	3.4 (0.134)	1.8 (0.071)	1.10 (0.043)	3
	MF-NSMF020	0.20	24	10	0.60	2.60			0.85 (0.033)	
	MF-NSMF035	0.35	6	100	0.30	1.20			0.85 (0.033)	
	MF-NSMF050	0.50	13.2	100	0.15	0.70			0.85 (0.033)	
	MF-NSMF075	0.75	6	100	0.10	0.29			0.70 (0.028)	
	MF-NSMF110	1.10	6	100	0.06	0.20			0.70 (0.028)	
	MF-NSMF150	1.50	6	100	0.03	0.13			0.70 (0.028)	

Selection of Radial Low Voltage Products

Features

- Bulk and Tape and Reel Packaging
- Resettable Circuit Protection
- Agency Approvals - UL, CSA, TÜV.
- Popular Footprints and Packaging
- Low Resistance
- Lead Free Options
- Custom Designs Available

Applications

- Computers and Peripherals
- General Electronics

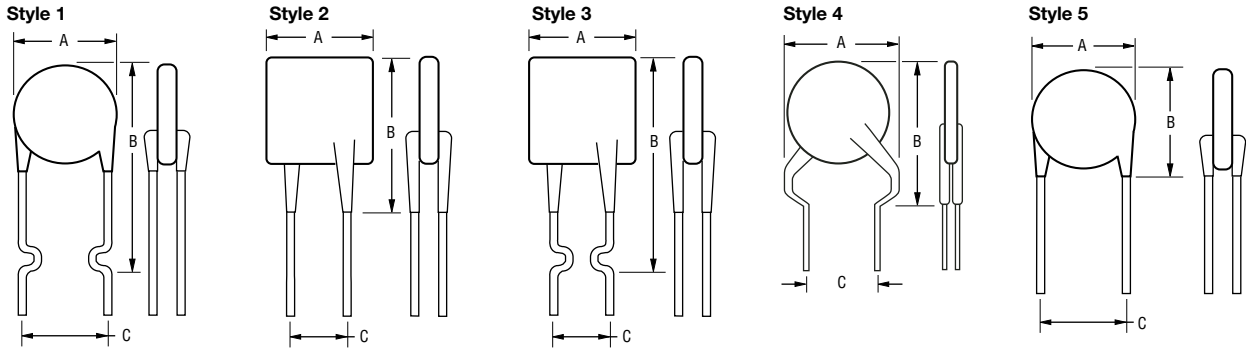

MF-RX/72 Series – Radial Leaded, 72 Volts

Typical Application: Transformer

RoHS Compliant

Model	I _{hold} (Amps @ 23 °C)	V max. (Volts)	I max. (Amps)	Initial Resistance (Ohms @ 23 °C Min.)	1 Hour (R1) Post-Trip Resistance (Ohms @ 23 °C Max.)	Dimensions [mm/(in)]			Style
						A Max.	B Max.	C Nom.	
 MF-RX110/72	1.10	72.0	40	0.15	0.38	10.84 (0.427)	16.8 (0.663)	5.1 (0.021)	2
MF-RX135/72	1.35			0.12	0.30	12.26 (0.483)	18.3 (0.720)	5.1 (0.021)	
MF-RX160/72	1.60			0.09	0.22	13.94 (0.549)	19.9 (0.785)	5.1 (0.021)	
MF-RX185/72	1.85			0.08	0.19	15.18 (0.598)	21.2 (0.834)	5.1 (0.021)	
MF-RX250/72	2.50			0.05	0.13	17.84 (0.702)	23.8 (0.939)	10.2 (0.402)	
MF-RX300/72	3.00			0.04	0.10	20.67 (0.814)	26.7 (1.050)	10.2 (0.402)	
MF-RX375/72	3.75			0.03	0.08	23.51 (0.926)	29.6 (1.162)	10.2 (0.402)	

MF-R Series – Radial Leaded, 16-60 Volts

Typical Application: Transformer

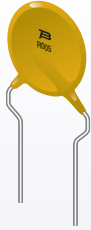
Model	Ihold (Amps @ 23 °C)	V max. (Volts)	I max. (Amps)	Initial Resistance (Ohms @ 23 °C Min.)	1 Hour (R1) Post-Trip Resistance (Ohms @ 23 °C Max.)	Dimensions [mm/(in)]			Style	
						A Max.	B Max.	C Nom.		
 MF-R005	0.05	60	40	7.3	22	8.0 (0.315)	8.3 (0.327)	5.1 (0.021)	4	
MF-R010	0.1	60		2.5	7.5	7.4 (0.291)	12.7 (0.500)	5.1 (0.021)	1	
MF-R017	0.17	60		2	8	7.4 (0.291)	12.7 (0.500)	5.1 (0.021)	1	
MF-R020	0.2	60		1.5	4.4	7.4 (0.291)	12.7 (0.500)	5.1 (0.021)	1	
MF-R025	0.25	60		1	3	7.4 (0.291)	12.7 (0.500)	5.1 (0.021)	1	
MF-R030	0.3	60		0.76	2.1	7.4 (0.291)	13.4 (0.528)	5.1 (0.021)	1	
MF-R040	0.4	60		0.52	1.29	7.4 (0.291)	13.7 (0.539)	5.1 (0.021)	1	
MF-R050	0.5	60		0.41	1.17	7.9 (0.311)	13.7 (0.539)	5.1 (0.021)	1	
MF-R065	0.65	60		0.27	0.72	9.7 (0.382)	15.2 (0.598)	5.1 (0.021)	1	
MF-R075	0.75	60		0.18	0.6	10.4 (0.409)	16.0 (0.630)	5.1 (0.021)	1	
MF-R090	0.9	60		0.14	0.47	11.7 (0.461)	16.7 (0.657)	5.1 (0.021)	1	
MF-R090-0-9	0.9	30		0.07	0.22	7.4 (0.291)	12.2 (0.480)	5.1 (0.021)	3	
MF-R110	1.1	30		0.1	0.27	8.9 (0.350)	14.0 (0.551)	5.1 (0.021)	1	
MF-R135	1.35	30		0.065	0.17	8.9 (0.350)	18.9 (0.744)	5.1 (0.021)	1	
MF-R160	1.6	30		0.055	0.15	10.2 (0.402)	16.8 (0.661)	5.1 (0.021)	1	
MF-R185	1.85	30		0.04	0.11	12.0 (0.472)	18.4 (0.724)	5.1 (0.021)	1	
MF-R250	2.5	30		0.025	0.07	12.0 (0.472)	18.3 (0.720)	5.1 (0.021)	2	
MF-R250-0-10	2.5	30		0.025	0.07	11.4 (0.449)	18.3 (0.720)	5.1 (0.021)	3	
MF-R300	3	30		0.02	0.08	12.0 (0.472)	18.3 (0.720)	5.1 (0.021)	2	
MF-R400	4	30		0.01	0.05	14.4 (0.567)	24.8 (0.976)	5.1 (0.021)	2	
MF-R500	5	30		0.01	0.05	17.4 (0.685)	24.9 (0.980)	10.2 (0.402)	2	
MF-R600	6	30		0.005	0.04	19.3 (0.760)	31.9 (1.256)	10.2 (0.402)	2	
MF-R700	7	30		0.005	0.03	22.1 (0.870)	29.8 (1.173)	10.2 (0.402)	2	
MF-R800	8	30		0.005	0.03	24.2 (0.953)	32.9 (1.295)	10.2 (0.402)	2	
MF-R900	9	30		0.005	0.02	24.2 (0.953)	32.9 (1.295)	10.2 (0.402)	2	
MF-R1100	11	16		100	0.003	0.014	24.2 (0.953)	32.9 (1.295)	10.2 (0.402)	2

Note:

RoHS compliant by adding -99 at the end of the part number, i.e. MF-R010-2-99.

LPM – Line Protection Modules

Features

- Precision Thick-film Technology
- Withstands Lightning and AC Power Cross
- Assists Compliance with Telecordia (Bellcore) GR-1089
- Assists Compliance with ITU-T K.20
- Surface Mount Solution
- Designed to Fail Safely under Fault Conditions
- Optional One-shot Thermal Fuse
- Optional Resettable PTC
- UL 497A Recognized
- Non-flammable
- Standard Offerings
- Custom Designs
- Full Qualification Test Capabilities
- Central Office, Remote and Customer Premises Equipment Applications Include:
 - Analog Line Cards - xDSL Line Cards
 - Pairgain - VoIP
 - PBX systems - External and
 - LCAS Protection Intra-buildings

Custom Designs

In addition to the various standard off-the-shelf versions available, Bourns offers extensive custom options. Examples include:

- Variety of Packages, e.g. Vertical and Horizontal SMD
- Packaging Options, e.g. Trays, Tape and Reel, Bulk
- Additional Resistors, e.g. Ringing Power Resistors
- Additional Components, e.g. Fuses, PTCs, Overvoltage Protection
- Resistors from 5.6 Ω
- Ratio Matching: Down to 0.3 %, or Less with Special Limitations

For more information on custom packaging options please see page 74 and 75 for our full capability. Please contact your local representative to discuss custom packaging options.

Model	Schematic	Dimensions	Description
4B08B-511-500			<ul style="list-style-type: none"> • 2x 50 Ω, 1 % • 0.5 % matching • Thermal fuses
4B04B-502-RC	<p>Functional Schematic*</p>		<ul style="list-style-type: none"> • 1x R Ω, 5 % • Values 5.6-100 Ω • Thermal fuse
4B06B-512-RC			<ul style="list-style-type: none"> • 2x R Ω, 5 % • Values 5.6-100 Ω • 0.5 % matching • Thermal fuses

$$\text{DIMENSIONS} = \frac{\text{MILLIMETERS}}{\text{(INCHES)}}$$

Model	Schematic	Dimensions	Description
4A08P-505-RC			<ul style="list-style-type: none"> • 2x R Ω, 5 % • Values 5.6-100 Ω • 1 % matching
4A12P-516-500			<ul style="list-style-type: none"> • 4x 50 Ω, 1 % • 0.5 % matching • Thermal fuses
4B06B-514-500			<ul style="list-style-type: none"> • 2x 50 Ω, 1 % • 1.0 % matching • Resettable Multifuse® PPTC
4B07B-530-400			<ul style="list-style-type: none"> • 2x 40 Ω, 2 % • 0.5 % matching • Integrated overvoltage TISP®
4B06B-540-125/219			<ul style="list-style-type: none"> • 2x 10 Ω, 5 % • 2.0 % matching • Integrated overvoltage TISP®

DIMENSIONS = $\frac{\text{MILLIMETERS}}{\text{(INCHES)}}$

Bourns® Telefuse™ Telecom Fuses

Selection Guide

Features

- For Use in Telecommunication Circuit Applications Requiring Low Current Protection with High Surge Tolerance
- Overcurrent Protection to Telcordia GR-1089-CORE & UL 1950/60950
- Ideal for Protecting Central Office and Customer Premises Equipment, including POTS, T1/E1, ISDN and xDSL circuits
- Model B1250T Allows Overcurrent Compliance with Telecom Specifications including Telcordia GR-1089-CORE, UL 60950 and ITU K.20, K.21 and K.44
- Model B0500T is a Lower Current Version for Use in Applications where a Faster Opening Time May be Required
- Bourns® TISP® Thyristor Surge Protector Products are Recommended for the Overvoltage Section of the Circuit
- Agency Recognition: File: E198545

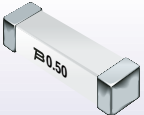
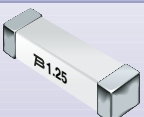
	Model Number	Ampere Rating (A)	Voltage Rating (Vrms)	Typical Cold Resistance (ohms)	Peak Surge Current* (Amps)	Power Fault 2.2 A, 600 V Clearing Time Max. (minutes)	Maximum Power Dissipation (W)
	B0500T	0.500	600	0.350	25	2	0.25
	B1250T	1.25	600	0.090	100	15	0.40

*50 pulses @ 1 kV 10/1000 μs

Body Material: Ceramic with tin plated brass caps

Solder: Lead free

Packaging: 2,000 pcs. per 13 " reel

Product Dimensions

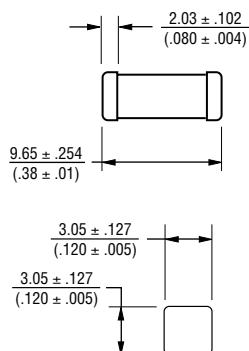

Recommended Pad Layout

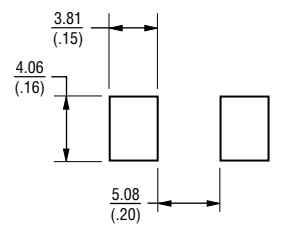

DIMENSIONS = $\frac{\text{MILLIMETERS}}{\text{(INCHES)}}$

ESD Components

ESD Overview

Electrostatic Discharge (ESD) is the transfer of electric charge between bodies of different electrostatic potential in proximity or through direct contact. The most common ESD event occurs from touching a metal doorknob or elevator button after walking across a carpet. Walking across a carpet in shoes with insulating soles causes the build up of static electricity on a person. In effect, the person becomes a charged capacitor which discharges to the metal object.

The International Electrotechnical Commission (IEC) developed a human model ESD test generator which would allow designers to verify equipment ESD performance. The IEC defines an ESD test

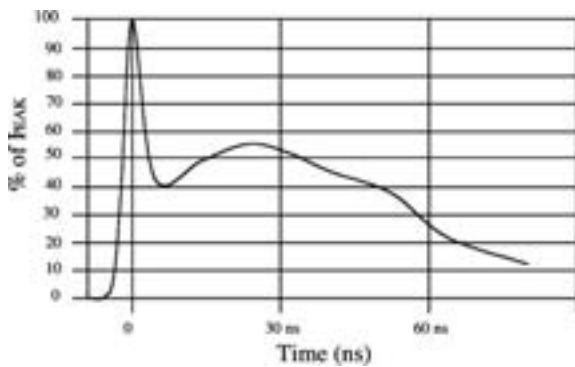

current impulse as having a rise time of less than 1 ns and decay time of 60 ns to 27 % as shown in the graph. The IEC ESD standard is IEC 61000-4-2 (2001-04) and it specifies four standard peak test generator voltages for air discharge and contact discharge together with a higher user defined level. Integrated Circuits (ICs) are ESD sensitive devices and their manufacturers design protection elements into the IC to increase its robustness. However, these protection circuits can add cost to the design by consuming silicon real estate. IC manufacturers design ICs to withstand a minimum IEC 61000-4-2 2 kV contact discharge voltage to provide protection during the board manufacturing process. Human body ESD voltages are nature determined and can be 15 kV or more, which may damage an IC. The highest standard air discharge voltage of IEC61000-4-2 is 15 kV to take this into account. Therefore, it is common practice to protect all “people interactive” data ports to a 15 kV level to avoid product damage during installation, use and servicing. Therefore, an external ESD protector provides the main level of protection with IC protection elements providing residual protection.

IEC61000-4-2 Level	Contact Voltage (kV)	Air Discharge Voltage (kV)	Peak Contact Current (A)	Contact Current @ 30 ns (A)	Contact Current @ 60 ns (A)
Level 1	2	2	7.5	4	2
Level 2	4	4	15	8	4
Level 3	6	8	22.5	12	6
Level 4	8	15	30	16	8

Bourns® ChipGuard® ESD Clamp Protection Products

Selection Guide

Bourns® ChipGuard® electrostatic discharge (ESD) protectors are based on a multilayer zinc oxide varistor (MLV) technology. The MLV technology provides excellent electrical performance with a competitive solution for many ESD requirements.

Features

- Designed to protect sensitive electronic circuits from the threat of ESD to IEC 61000-4-2 level 4
- 0402 and 0603 type packages

MLA Series – General ESD Protection

IC Power Supplies, Low Frequency Signal & Control Line Protection

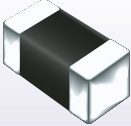
Model	Continuous Operating Voltage <50 μ A		Clamping Voltage VC (V) 1 A @ 8/20 μ s	Impulse Current ITM (Max.) (A) @ 8/20 μ s	WTM (Max.) (J) 10/1000 μ s	Capacitance CP (pF) Typ. 1 Vrms @ 1 MHz
	V rms (V)	V DC (V)				
 CG0402MLA-5.5MG	4	5.5	19	20	0.05	300
	11	14	38			100
	14	18	45			95
CG0603MLA-5.5ME	4	5.5	19	30	0.1	300
	11	14	35			160
	14	18	40			140
	20	26	58			120

MLC Series – High Speed Data and Communication Ports

USB 2.0, IEEE-1394, SCSI, DVI, Antenna and 1 Gb Ethernet

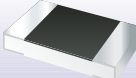
Model	Continuous Operating Voltage VDC (V)		Clamping Voltage VC (V)		Off-state Current IL Max. nA 1 Vrms @ 1 MHz	Trigger Voltage VT V VDC = max. rating	Capacitance Coff Max. pF Max.
	Typ.	Max.	Typ.	Max.			
 CG0603MLC-05E	5	6	20	35	50	150	0.5
	12		30	50			

MLD Series – High Speed Data Applications

USB 2.0, IEEE-1394, 10/100 Mb Ethernet

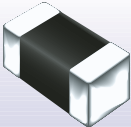
Model	Continuous Operating Voltage V DC (V) Max.	Breakdown Voltage VB @ 1 mA (V) Typ.	Clamping Voltage VC @ 1 A 8/20 μ s (V) Max.	Off-state Current IL (μ A) Max.	Capacitance COFF (pF) Max.
 CG0402MLD-12G CG0603MLD-12E	12	50 ~ 60	140	1	5

MLE Series – High Speed Protection Lines

Ethernet, RS232, RS485 ports

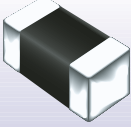
Model	Continuous Operating Voltage			Clamping Voltage VCLAMP (V) Typ.			Off-state Current IL (μ A) Max.					Capacitance CP (pF) Max.
	Vrms (V)		VDC (V)	8 kV ESD Contact	15 kV ESD Air	1 A @ 8/20 μ s	3.5 V	5.5 V	9 V	12 V	18 V	1 Vrms @ 1 MHz
	Max.	Typ.	Max.									
 CG0402MLE-18G CG0603MLE-18E	8.5	12	18	100	120	50	0.3	0.4	0.5	1	10	9
40				60	60	50						

Notes:

- All electrical characteristics @ 25 °C unless otherwise stated.
- Bourns® ChipGuard® electrostatic discharge (ESD) protectors are currently limited to a small range of voltage options. However, the MLV process allows a wider range to be manufactured. Should a voltage that is not highlighted in the current selection be required, please inquire with your local representative as Bourns plans to expand the family in the future.

Diode Arrays for ESD Protection



Selection Guide

Bourns offers a family of Diode Arrays for ESD protection. The ESD protection is implemented using Zener or TVS diodes in a Chip Scale Package (CSP) connected directly to the I/O port, or alternatively using Schottky diodes in a leaded QSOP package connected in a rail-to-rail configuration. Depending on the end application, the number of ports for protection and maximum capacitance levels can be selected from the table.

Features

- Diode Array
- Stable TFOS Technology
- JEDEC Standard Packages
- ESD Protection: IEC61000-4-2

Applications

- Bidirectional Parallel Port Communications
- Computers & Peripherals
- Instrumentation

2DAA ESD Diode Array – Package Schematic

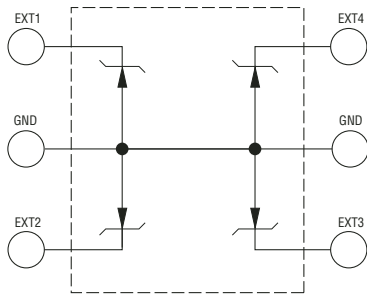

2DAB ESD Diode Array – Package Schematic

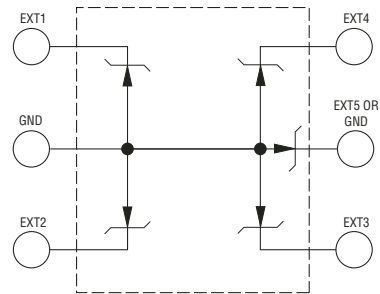

2DAC ESD Diode Array – Package Schematic

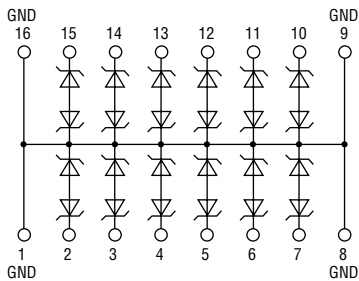

2DAD ESD Diode Array – Package Schematic

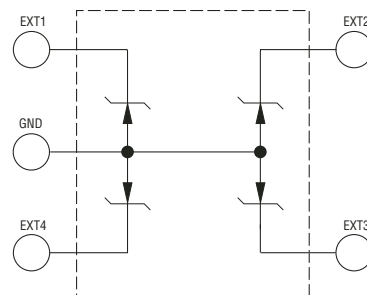

2DEA ESD Diode Array – Package Schematic

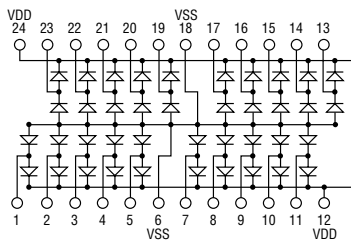

Application	I/O Ports	Cap Value (pF)	ESD Withstand (IEC 61000-4-2) Minimum	Part Numbers	
				Tape & Reel	Tubes
ESD Diode Array	4	150	±8 kV Contact ±15 kV Air	2DAA-F6R	-
	4 or (5 Uni)	150		2DAB-F6R	-
	12	10.5		2DAC-C16R	-
	4	15		2DAD-C5R	-
	20	5		2DEA-2-Q24R	2DEA-2-Q24T

Note:
For Lead Free solution, add "LF" suffix to part number above.

CSP Package – 5 I/O

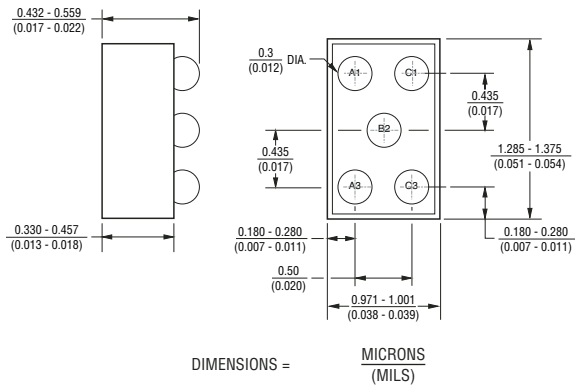

CSP Package – 6 I/O

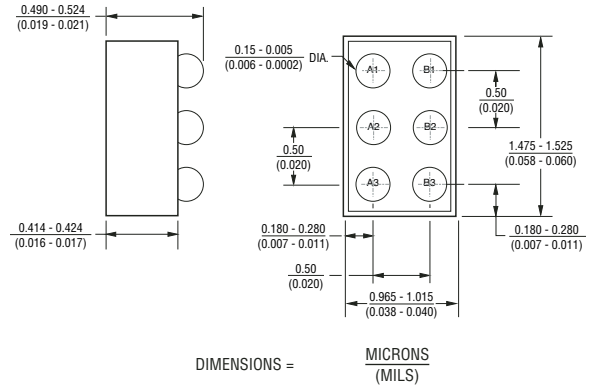

CSP Package – 16 I/O

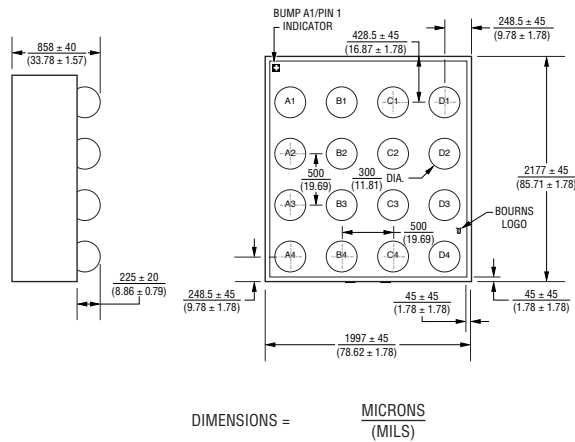

QSOP Package Dimensions

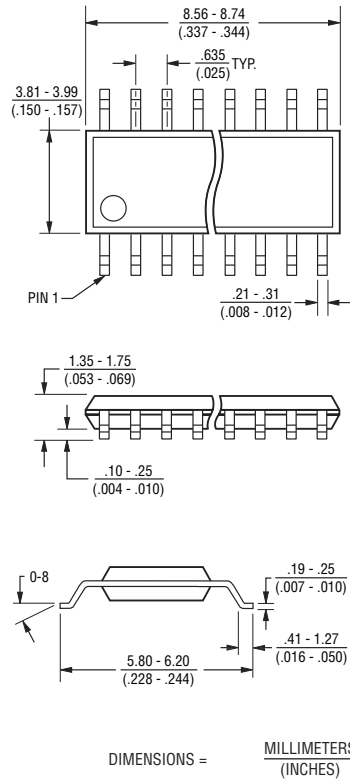

Outside Plant Products

Bourns offers a full line of Overvoltage Protectors based on our Gas Discharge Tube (GDT) and patented Multi-Stage Protection (MSP®) technology. Products include 5-Pin Protectors for Central Office and Building Entrance protection, as well as Station Protectors and POTS splitters for Network Interface Devices (NID) for customer premises protection.

Our 241x and 242x series 5-Pin Protectors are highly reliable and cost effective solutions for Central Office and Building Entrance protection. We offer a wide variety of color coded modules with custom configurations. Both series are available with GDT or MSP® technology, offering long surge life, high surge handling capability and low capacitance for broadband applications.

For Customer Premises, we offer a complete line of fully modular Network Interface Devices available from one to one hundred lines. The NIDs are available in fire retardant, ultraviolet resistant plastic or zinc coated, rust resistant metal housings. All NIDs are designed to provide maximum wire management space and flexibility and are available in many custom configurations, including our 1740 series protector addition for 75-Ohm Coax cable protection.

Additionally, we offer a full line of Station Protectors, ADSL and VDSL splitters with binding post or IDC terminations and totally integrated protector-subscriber bridge modules in a snap-in configuration. Our 23xx series Station Protectors are offered with GDT, MSP® or Solid State technology. The 36xx series POTS splitters are designed to meet all relevant ANSI specifications and all our protector products and accessories are UL listed and manufactured to RUS and Telcordia technical requirements.



Residential Network Interface Devices



Commercial Multipair Network Interface Devices



NID Protector Terminals



NID Enclosures

Bourns® OSP Products – Continued



*DigiGuard™ MSP® Broadband Protectors –
Balanced Capacitance (BC) versions available for VDSL*



Standard Station Protectors



DSL Splitters – ADSL (left) and VDSL (right)



5-Pin Broadband Protectors



Well Protectors



5-Pin Broadband Protectors

Outside Plant – Signaling Systems Surge Protectors

Bourns® 1669 protectors are designed to protect field-mounted 4-20 mA transmitters. The 1669 series features a sealed stainless steel pipe for easy connection to a field transmitter 1/2 inch NPT port. A railmounted 1820-28-Ax is typically used to protect the Digital Carrier System equipment at the opposite end of the loop.

1669 Series – Transient Protector Selection Guide

Model	Max. Signal Voltage	DC Clamping Voltage		Capacitance 1 MHz, Max.		Series Resistance per Line (Ω)	Inductance per Line, Max. (μ H)	DC Leakage V DC, Max. (μ A)	Impulse Clamping 1 kA (L+L)-G		Surge Life	
		L/L (V)	L/G (V)	L/L (pF)	L/G (pF)				10/1000 μ s L/L (V)	500 V/ μ s L/G (V)	20 kA 8/20 μ s (times)	1 kA 10/100 μ s (times)
1669-01 1669-05	30	36	250	1200	40	22	1	1	50	750	20	1000
1669-02 1669-06			36	2000	2000					70		

1669-06 Product Dimensions

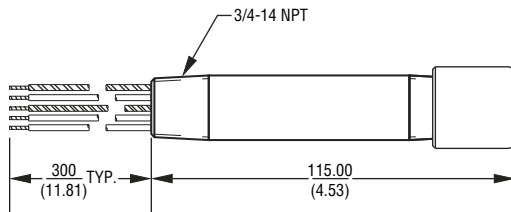

1669-02 Product Dimensions

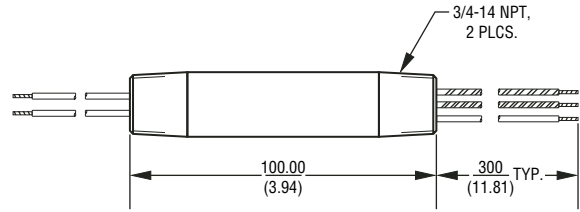

DIMENSIONS = $\frac{\text{MILLIMETERS}}{\text{(INCHES)}}$

1800 Series – Signal and Dataline Protector Selection Guide

Mounting Detail	Typical App.	Interface Operating Characteristics			Protective Characteristics Peak Clamping Voltages				Max. DC Current (mA)	Typical Capacitance		Series Resistance Each Line (input to output) (Ohms)
		Peak Signal Voltage		Max. Data Rate (MHz)	@ 5 kA, 8 x 20 μs rate of rise		@ 1 kA, 8 x 20 μs rate of rise			L/L (pF)	L/G (pF)	
		L/L (V)	L/G (V)		L/L (V)	L/G (V)	L/L (V)	L/G (V)				
1810-10-xx	RS-422	20	10	10	50	25	42	21	220	1200	2200	10
1820-10-xx		10	10	4	25	25	21	21	220	3300	3300	10
1811-10-xx		20	10	50	60	30	52	26	350	45	45	10
1821-10-xx		10	10	50	30	30	26	26	350	65	65	10
1810-15-xx	RS-232	30	15	8	70	35	56	28	180	750	1500	15
1820-15-xx	RS-485	15	15	3	35	35	28	28	180	2300	2300	15
1811-15-xx	4-20 mA	30	15	45	80	40	64	32	300	45	45	15
1821-15-xx		15	15	45	40	40	64	32	300	65	65	15
1810-28-xx		56	28	9	110	55	90	45	150	600	1100	22
1820-28-xx		28	28	4	55	55	45	45	150	1800	1800	22
1811-28-xx		56	28	40	120	60	45	45	250	45	45	22
1821-28-xx		28	28	40	60	60	45	45	250	65	65	22
1810-50-xx		100	50	10	178	89	156	89	100	30	5000	51
1820-50-xx		50	50	4	89	89	45	45	100	800	800	51

Surge Life:

> 100 operations 200 Amps, 10 x 1000 μsec

> 10 operations 10 kA, 8 x 20 μsec

1800 Series Signal/Data Attenuation at Maximum Data Rate: 3 db with 600 Ω Termination

Operating Temperature:

1669 Series -40 to +100 °C

1800 Series -40 to +60 °C

1820-28-A1 Product Dimensions

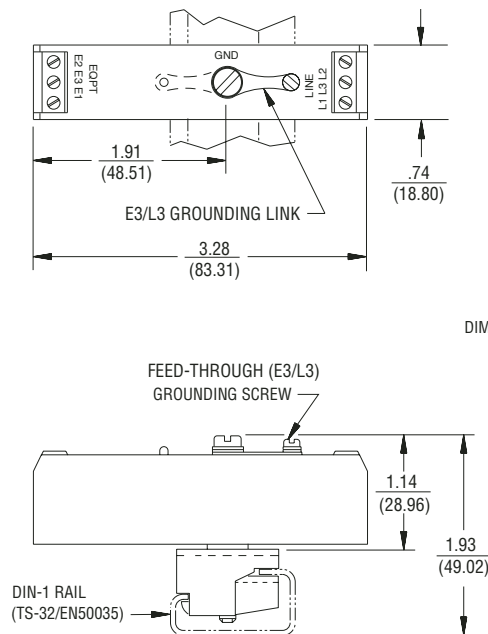

DIMENSIONS = $\frac{\text{MILLIMETERS}}{\text{(INCHES)}}$

1820-28-A3 Product Dimensions

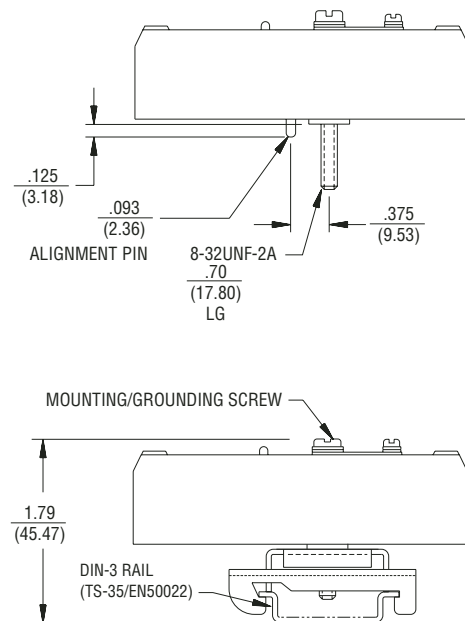

Other Related Products & Capabilities

Bourns offers a wide range of Transformers suitable for use in Telecom, LAN and Ethernet applications. These devices are available in a range of surface mount and through-hole packages as well as some low profile devices for PCMCIA applications. A summary of part numbers by application is below.



PT60001 – LAN 10Base-T, 10Base-5, 10Base-2

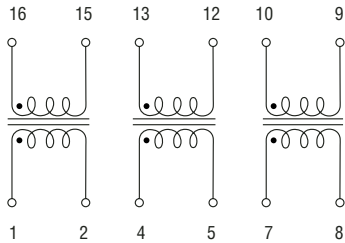

PT60006 – LAN 100Base-TX

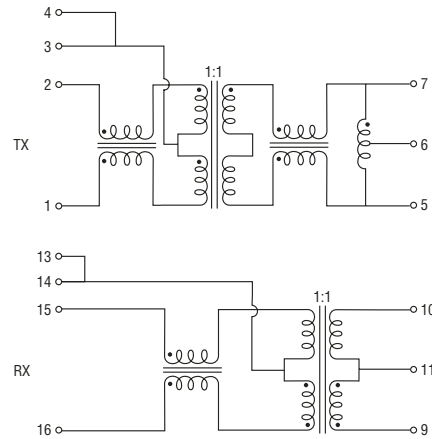

PT60007 – LAN 10Base-T/100Base-TX QUAD

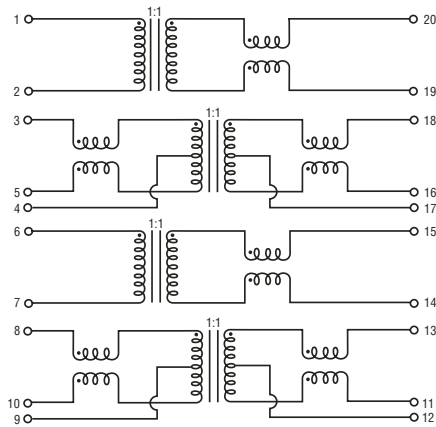

PT60003 – LAN 10Base-T/100Base-TX PCMCIA

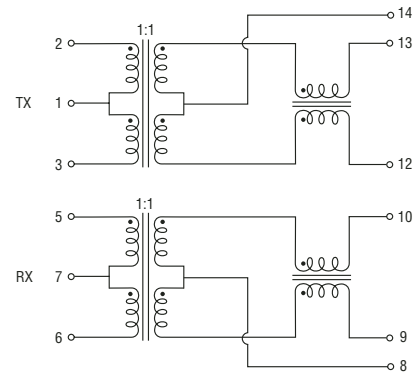

PT60005 – LAN 10Base-T/100Base-TX

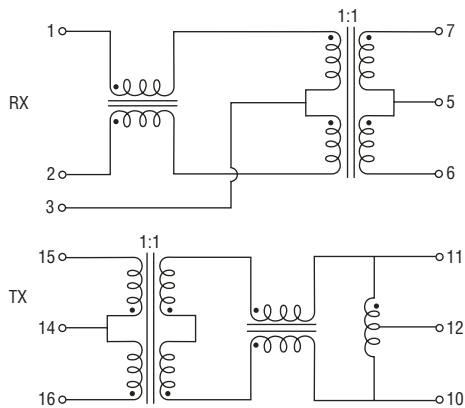

PT60010 – LAN 100Base-TX QUAD

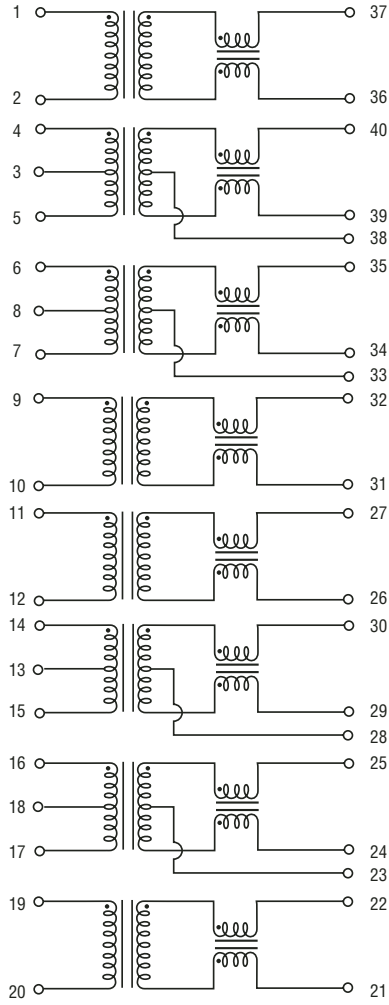

PT60011 – LAN 10-100Base-TX QUAD

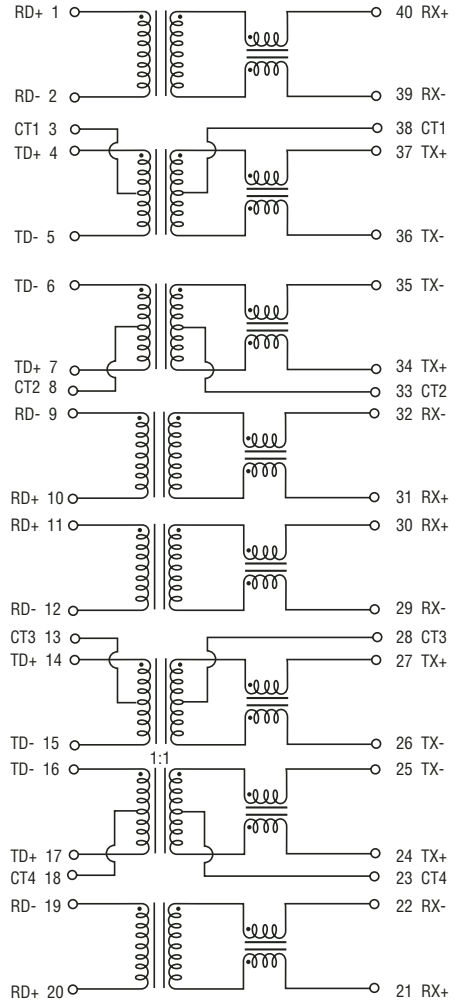

PT61005 – LAN 10Base-T Filter Interface

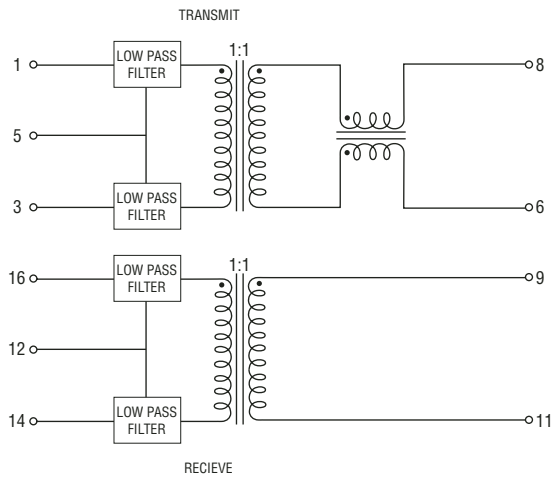

PT60014 – LAN 10Base-T/100Base-TX PCMCIA

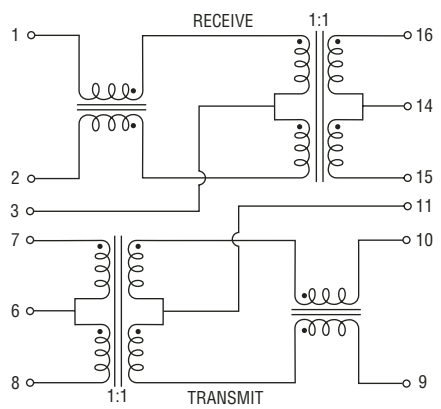

PT61007 – LAN 10Base-T/100Base-TX QUAD

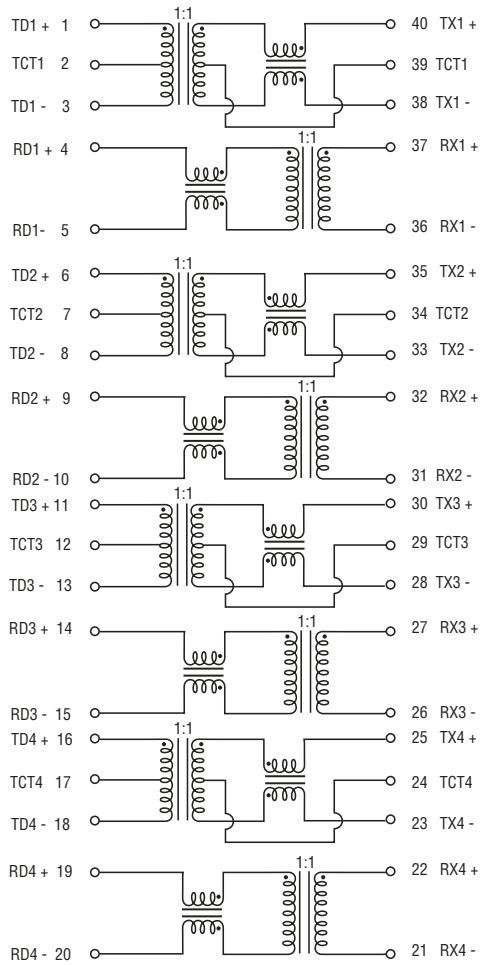

PT61003 – LAN 10Base-T/100Base-TX High Speed

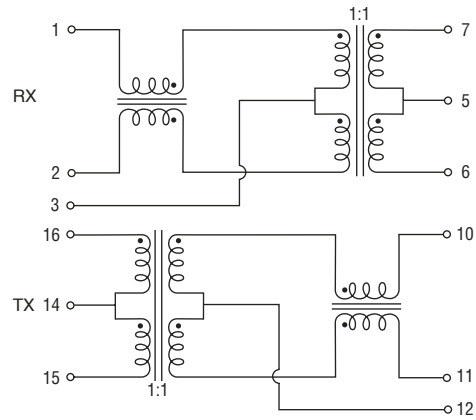

PT61010 – LAN 10Base-T

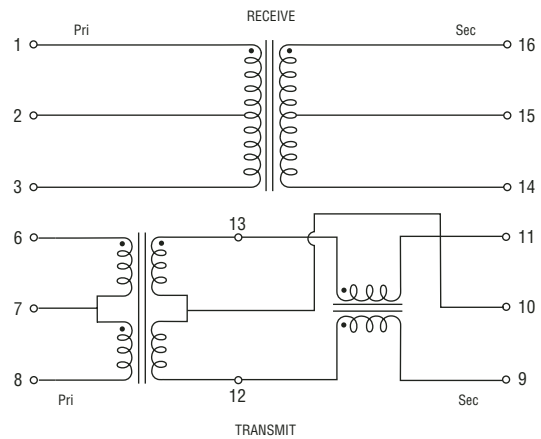

PT66001 – ISDN S-Interface Transformer Module

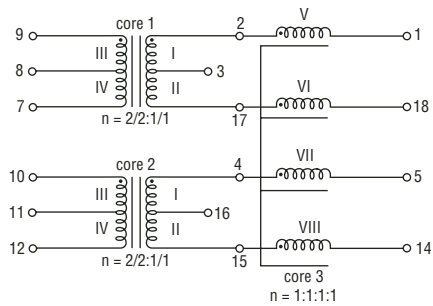

PT61004 – LAN 10Base-T Filter Interface

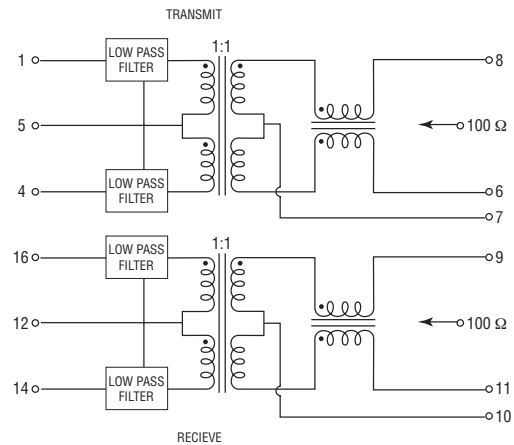

PT66002 – T1 Transformer

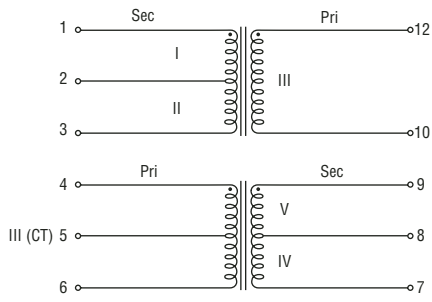

PT66003 – T1/CEPT Transformer

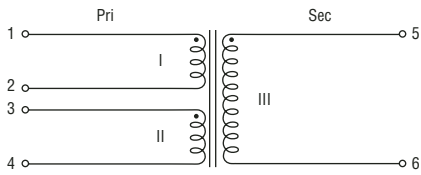

SM76299 – SHDSL Line Transformer

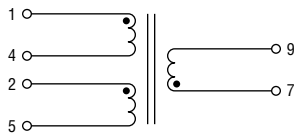

SM535-1 – ADSL Line Transformer

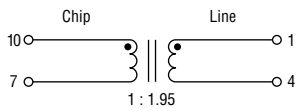

PT66004 – ISDN S-Interface Transformer

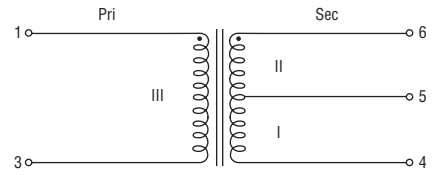

PT66005 – T1/CEPT/ISDN-PRI Transformer

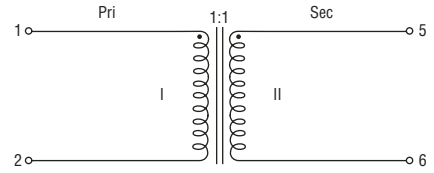

PT534-1 (1:1) – ADSL Line Transformer

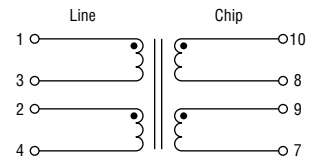

SM-LP-5001 – Series SM Line Matching Transformer

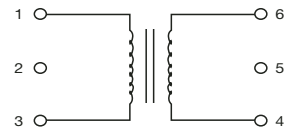

Bourns® Microelectronic Modules Packaging Solutions

Device Mounting Technology

Surface Mount Technology

Surface mounting is still the most common and economical approach for many applications. Bourns® Microelectronic Module products offer the latest in surface mount technology:

- Chip sizes to 0201
- Inert reflow
- SOIC, PLCC, TSOP, QFP to 0.012 " (0.3 mm)
- Lead free solder capability
- CSP, odd form components
- Passive component test
- BGA: 0.5 mm pitch, underfill

Chip & Wire/COB (Chip on Board)

This proven technology provides an intermediate level of miniaturization, the advantages of in-process test and repair and is designed to withstand harsh environments such as automotive applications.

Bourns® Microelectronic Module products offer the latest in chip & wire technology:

- Gold & Aluminum Wire Bonding – High speed, automated, ball/wedge, wedge/wedge, ribbon
- Gold Wire Bonding – 20-50 μm (0.8 to 2 mil) wire to 100 μm (4 mil) pitch
- Aluminum Wedge Bonding – 125-380 μm (5 to 15 mil) wire for high current/power applications
- Die Attachment – Epoxy or Eutectic, 5 μm accuracy, glob top, dam & fill

Flip Chip Mounting

This process provides the ultimate opportunity for package miniaturization and minimization of conductor lengths and size reduction in high speed, high frequency applications.

Bourns® Microelectronic Module products offer a choice of flip chip approaches:

Anisotropic Adhesive Attachment (Z-axis conductive epoxy)

- Ideal for PCB and flex circuits
- High I/O
- Tight pitch
- Cost-effective flip chip solution
- Utilizes off-the-shelf wire bondable ICs



Thermal-Sonic Bonding (Gold-to-Gold Interconnect)

- Ideal for high frequency applications and MEMS to ceramic substrates
- I/O limited to ~32 or less
- Underfill optional
- Low temp process
- Lead free

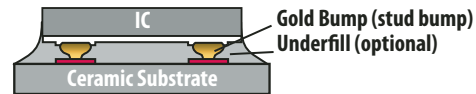

Stud Bump bonding

- Ideal for high I/O flip chip to ceramic substrate
- Mid-process replacement of faulty chips
- Underfill required
- Proven technology with reliability data
- Utilizes off-the-shelf wire bondable ICs

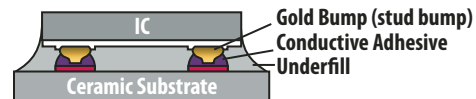

Solder Mounting

- Standard flip chip technology
- Solder bumped devices
- Optional underfill
- Z-axis control for ultimate strength
- High volume cost-effective solution

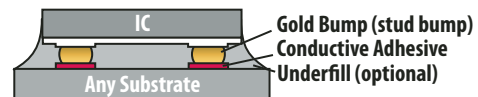

Full Process for Stud Bump Bonding

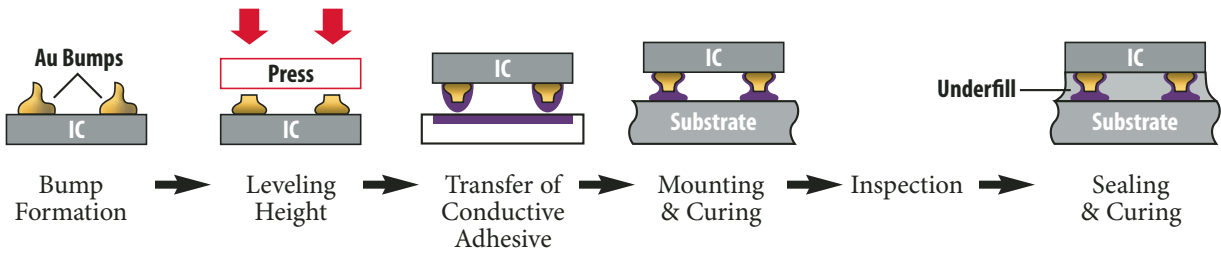

Choice of Package Interconnects

- CSP (Chip Scale Packaging) – smallest package for surface mounting
- MCM (Multichip modules) – smallest package for multichip hybrid

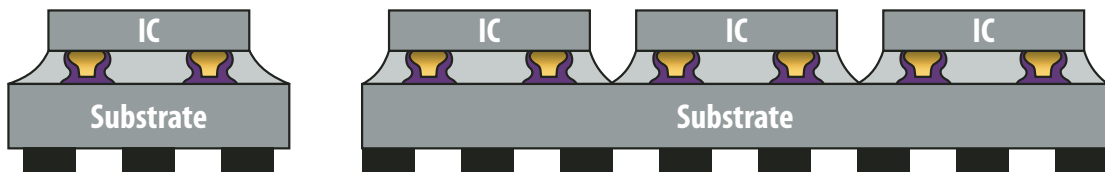

- SIP (Single Inline Packaging) – 0.050 ", 0.100 " and 1.8 mm
- DIP (Dual Inline Packaging) – 0.100 "
- BGA (Ball Grid Array)
- QFP (Quad Flat Pack)
- J-Leads in Dual or Quad configuration – 0.050 ", 0.075 " and 0.100 "
- Mini-DIL
- TO-cans
- Butterfly
- Hermetic Seal

Bourns® Switch Power DC/DC Converters

Bourns Switch Power has brought innovative product solutions and ideas to the power conversion market since 1995. Our emphasis on high performance converters has given us a broad and expanding selection of power solutions. Our focus on the communications market gives us the advantage of experience when developing high reliability products. Our technological innovation has produced patents covering all aspects of DC-DC Converter development: from controller IC design through power train layout, resulting in better performance, higher density and higher reliability products.

Non-Isolated Converters

Bourns® Switch Power's Non-Isolated Converters provide the low voltages needed to support core logic, ASICs, microcontrollers and microprocessors. These high-efficiency converters provide improved regulation and superior dynamic response. In many cases this is thanks to Bourns Switch Power's patented V2TM architecture. High power density in both SIP and surface mount module packages ensure compatibility with most size requirements.



Input Voltages: 3.3 V, 5 V, 12 V

Output Currents: 2 A to 32 A

Output Voltages: 0.8 V to 5.0 V



Typical Applications for Point of Load DC/DC Converters:

- Low voltage, high density systems with Intermediate Bus Architectures (IBA)
- Workstations, servers, and desktop computers
- Distributed power architectures
- Telecommunications equipment
- Latest generation ICs (DSP, FPGA, ASIC) and microprocessor-powered applications
- Data processing equipment
- Broadband, networking, optical and communications systems

SLIC Power

The SLIC Power series of products provides high-performance power and low cost to Ringing SLIC users. Rather than spending time designing and testing specialized power circuits, the designer can simply select the appropriate SLIC Power module. Whether comparing cost, space or design time, the SLIC Power modules can meet or exceed other options.



Input Voltage	V _{BAT1/2}		
	-72 V / -24 V	-63 V / -24 V	-60 V / -24 V
5.0 V	SPT5504C	SPT5504CL	SPT5504Q
12 V	SPT5204Q	SPT5204QL	—

48 Volt Power

Our M20W power module is an industrial temperature range, dual-output device. The system designer obtains flexibility in choosing 5 V and 3.3 V components, based on the ability of the module to supply either voltage over a wide power range to the load. The output voltages are tightly and independently regulated, thus eliminating the common problem of cross regulation errors between the outputs. The module is designed with Switch Power's resonant primary and synchronous secondary topology for enhanced reliability and high efficiency, allowing high-temperature operation.



Custom Power

Bourns can design and produce Custom Power solutions for your specific application. The standard fixed product is available in output voltages not specified in this catalog. Please contact application support for more information.

Which Protection Technology is Right for the Equipment?

There are several individual technologies within each of the core protection types listed in Table 1. No single protection technology offers an ideal solution for all requirements. Each technology has different strengths and weaknesses, and only by understanding their relative merits can protection be optimized for a given installation. A quick review of Table 2 demonstrates that no single ideal solution exists for all locations within the telephone network so cascaded protection is often deployed.

Protection Type	Action	Connection
Overcurrent	Limit peak current	Series (or parallel for primary)
Overvoltage	Limit peak voltage	Parallel
Overcurrent and Overvoltage	Coordinate voltage and current protection	Combination

Table 1. Protection falls into three basic types

Overvoltage

	Speed	Accuracy	Current Rating
GDT	Fair	Fair	Very high
Thyristor	Fair	Good	High
MOV	Fair	Poor	High
TVS	Very fast	Good	Very low

Overcurrent

	Speed	Accuracy	Current Rating
Polymer PTC Thermistor	Fair	Good	Low
Ceramic PTC Thyristor	Slow	Good	Low
Fuse	Very slow	Fair	Medium/High
Heat Coil	Very slow	Poor	Low
Thermal Switch	Very slow	Poor	High

Table 2. Summary of technology characteristics

Good protection design necessitates an understanding of the performance trade-offs and benefits of each device type, as well as the terminology used in their specifications. Adequate grounding and bonding, to reduce potential differences and provide a low impedance current path is a prerequisite for coordinated system protection (GR-1089-CORE, Section 9).

The Basics – Overvoltage and Overcurrent

Protection devices fall into two key types, overvoltage and overcurrent. Overvoltage devices (see Figure 1) divert surge current (such as lightning), while most overcurrent devices (see Figures 2a-2c) increase in resistance to limit the surge current flowing from longer duration surge currents (50/60 Hz power fault). There are two types of voltage limiting protectors: switching devices (GDT and Thyristor) that crowbar the line and clamping devices (MOV and TVS). The inset waveforms of Figure 1 emphasize that switching devices results in lower stress levels than clamping devices (shaded area) for protected equipment during their operation. Functionally, all voltage protectors reset after the surge, while current protectors may or may not, based on their technology. For example, PTC thermistors are resettable; fuses are non-resettable as shown in Table 3.

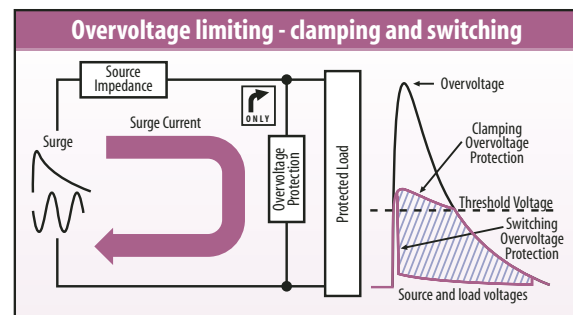

Figure 1. Overvoltage protection provides a shunt path for surges

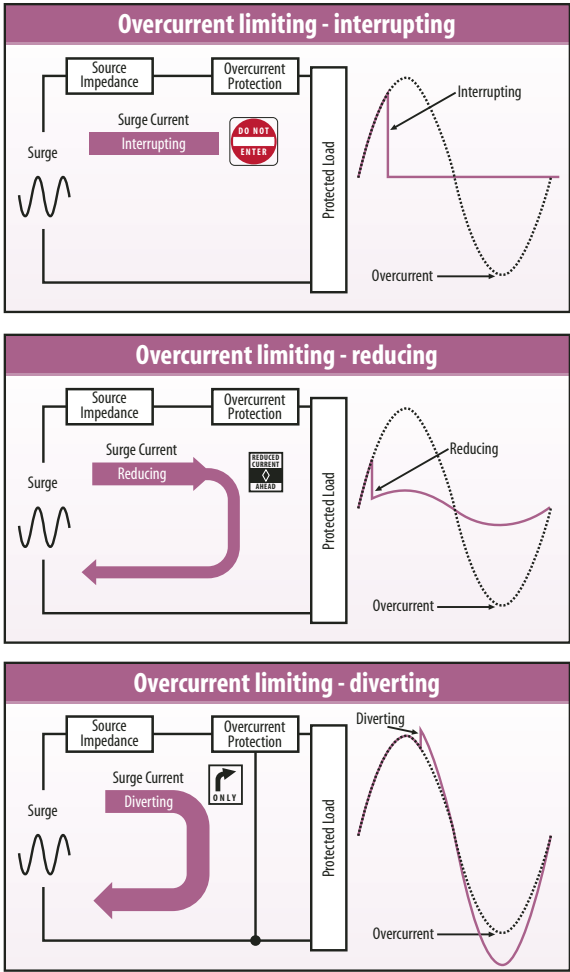

Figure 2a-2c. Overcurrent protection isolates the equipment by presenting a high impedance

What Happens After a Surge or if the Device Fails?

In addition to preventing a surge from destroying equipment, resettable devices return the equipment to pre-event operation, eliminating maintenance cost and maximizing communications service. In addition, lightning typically consists of multiple strikes. It is, therefore, essential to consider subsequent surges. Because lightning and power cross standards are not intended to represent the maximum surge amplitudes in the field, an understanding of what happens under extreme conditions is equally important.

Overvoltage

Action	Connection	Examples
Voltage switching	Shunt	GDT, Thyristor
Voltage clamping	Shunt	MOV, TVS

Overcurrent

Action	Connection	Examples
Resettable	Series	PTC thermistor - Ceramic - Polymer
Non-resettable	Series	Fuse
Non-resettable	Shunt or series	Heat coil
Non-resettable	Series	LFR (Line Feed Resistor)
Non-resettable	Across voltage limiter	Fail-short device for thermal overload

Table 3. The basic classes of protection devices

A shunt device failing open circuit effectively offers no follow-on protection, although under normal conditions the telephone line will operate. If the device fails to a short circuit, the line is out of service, but further damage is prevented. In addition, other issues such as exposed areas prone to heavy surge events or remote installations where maintenance access is difficult may strongly influence selection of the most suitable protection technology (see Table 4).

Reliability Tip
Complying with standards does not guarantee field reliability.

Overvoltage

	Suitable for Primary (P) or Secondary (S) ^{1,2}	Normal Operation	After Excess Stress ³	
		After Operation	Still Protecting?	Line Operating?
GDT	P or S	Reset to Normal	Yes/No	No/Yes
GDT + Thermal Switch	P		Yes	No
Thyristor	P or S		Yes	No
Thyristor + Thermal Switch	P		Yes	No
MOV	S		No	Yes
TVS	S		Yes	No

Overcurrent

	Normal Operation	After Excess Stress ³	
	After Operation	Still Protecting?	Line Operating?
PTC Thermistor	Reset to Normal	Yes	No
Fuse	Line Disconnected		
Heat Coil	Line Shorted or Open		
Thermal Switch	Line Shorted		
LFR	Both Lines Disconnected		

¹ Primary protection applications typically require specific fail-short protection.

² Secondary protection requires a fused line (USA).

³ The failure mode depends on the extent of the excess stress. Comments made for a typical condition that does not fuse leads.

Table 4. The status after the protection has operated can be a significant maintenance/quality of service issue

Speed and Accuracy are Major Control Factors in Determining Equipment Stress Levels

The behavior of each technology during fast surge events can have a substantial effect on maximum stress as summarized in Table 5a and 5b. In addition to device tolerance, each device requires a finite time to operate, during which the equipment is still subjected to the unlimited surge waveform. Before operation, some technologies allow significant overshoot above the ‘operating’ level. The worst-case effects determine the stress seen by the equipment and not just the nominal “protection” voltage or current (see Figure 3).

Overvoltage protection technologies may be summarized as follows:

- GDTs offer the best AC power and high surge current capability. For high data rate systems (>30 Mbs), the low capacitance makes GDTs the preferred choice.
- Thyristors provide better impulse protection, but at a lower current.
- MOVs are low cost components.
- TVS offers better performance in low dissipation applications.

Overvoltage Limiters

Type		Performance			
Class	Technology	Voltage Limiting Speed	Voltage Precision	Impulse Current Capability	Low Capacitance
Switching	Gas Discharge Tube				
	Thyristor				
Clamping	Metal-Oxide Varistor				
	TVS				

Table 5a. No overvoltage technology offers an ideal solution for all applications

Overcurrent Limiters

Type		Performance			
Class	Technology	Fast Operation	Resistance Stability	Low Operating Current	Low Series Resistance
Reducing	Polymer PTC Thermistor	→ BEST	→	→ BEST	→
	Ceramic PTC Thermistor	→	→	→ BEST	→
Interrupting	Fuse	→	→ BEST	→	→ BEST
	Line Feed Resistor	→	→ BEST	→	→
Diverting	Heat Coil	→	→	→ BEST	→
	Thermal Switch	→	→ BEST	→	→ BEST

Table 5b. No overcurrent technology offers an ideal solution for all applications

Overcurrent protection technologies may be summarized as follows:

- PTC thermistors provide self-resetting protection.
- Fuses provide good overload capability and low resistance.
- Heat coils protect against lower level ‘sneak currents’.
- LFRs provide the most fundamental level of protection, combined with the precision resistance values needed for balanced lines and are often combined with other devices.

Technology Selection - Overvoltage Protectors

Voltage limiting devices reduce voltages that exceed the protector threshold voltage level. The two basic types of surge protective devices are clamping and switching, Figure 8. Clamping type protectors have a continuous voltage-current characteristic (MOV and TVS), while the voltage-current characteristic of the switching type protector is discontinuous (GDT and Thyristor). A series or shunt combination of clamping and switching type devices may provide a better solution than a single technology. Utilize the decision trees in Figures 4-7 to aid in the election of a suitable circuit protection solution. Comparative performance indicators and individual device descriptions beneath each decision tree allow designers to evaluate the relative merits for each individual or combination of technologies. The lower density and increased exposure of rural sites suggests that heavier surges can be expected for these

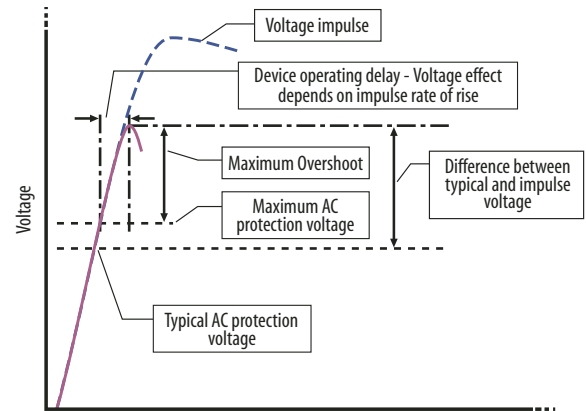

Figure 3. Systems must survive more than the nominal protection voltage

applications (Figure 4), while the cost and type of the protected equipment has an influence on the selection of secondary protection (Figure 5, 6, & 7).

Reliability Tip
Check worst-case protection values, not just nominal figures.

During the operation of overvoltage protectors, surge currents can be very high and PCB tracks and system grounding regimes must be properly dimensioned.

It is important that protectors do not interfere with normal operation. Although traditional telecom systems typically run at -48 V battery voltage plus 100 V rms ringing voltage (i.e. approximately 200 V peak), designers should consider worst-case battery voltage, device temperature and power induction

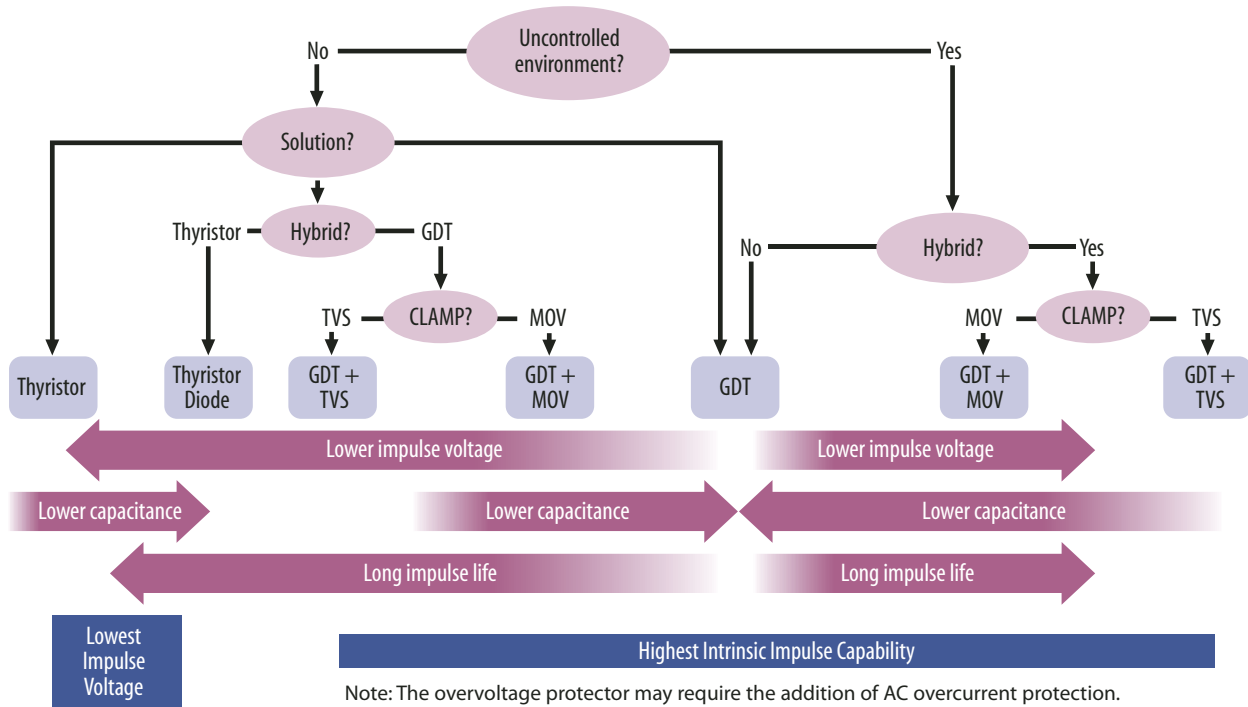

Figure 4. Primary overvoltage technology selection

Reliability Tip
Ensure that PCB tracks and wiring are dimensioned for surge currents.

voltages when specifying minimum protection voltage. Some digital services operate at much higher span voltages, requiring further consideration for equipment designed for broadband applications (see Table 2). The capacitance of overvoltage protectors connected across these lines is important - especially for digital connections such as ISDN and xDSL. Matched and stable devices are necessary to avoid introducing imbalance in the system.

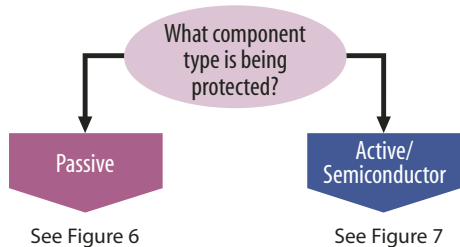
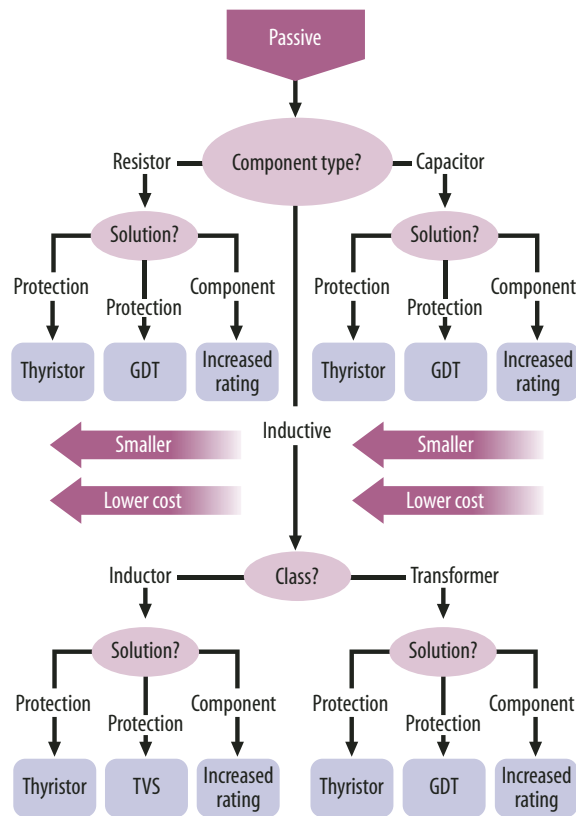

Figure 5. Secondary overvoltage protection depends on the type of component to be protected

Datasheet Tip
When protecting digital lines, check the tolerance and variation of protection capacitance (i.e. voltage dependence), not just nominal values.



Note: The overvoltage protector may require the addition of AC overcurrent protection.

Figure 6. Secondary protection of passive components

Gas Discharge Tubes (GDTs)

GDTs apply a short circuit under surge conditions, returning to a high impedance state after the surge. These robust devices with negligible capacitance are attractive for protecting digital lines. GDTs are able to handle significant currents, but their internal design can significantly affect their operating life under large surges (see Figure 9).

The sparkover voltage of GDTs increases at high rates of voltage rise (dv/dt). The level of increase depends on the actual rate of rise and the nominal DC sparkover voltage. For example at $100 \text{ V}/\mu\text{s}$, the impulse sparkover voltage of a 75 V GDT increases to approx. 250 V and the impulse sparkover of a 350 V GDT increases to approximately 600 V.

Their ability to handle very high surge currents for hundreds of microseconds and high AC for many seconds matches the primary protection needs of exposed and remote sites. During prolonged AC events, GDTs can develop very high temperatures, and should be combined with a thermal overload switch that mechanically shorts the line (Switch-Grade Fail-Short mechanism).

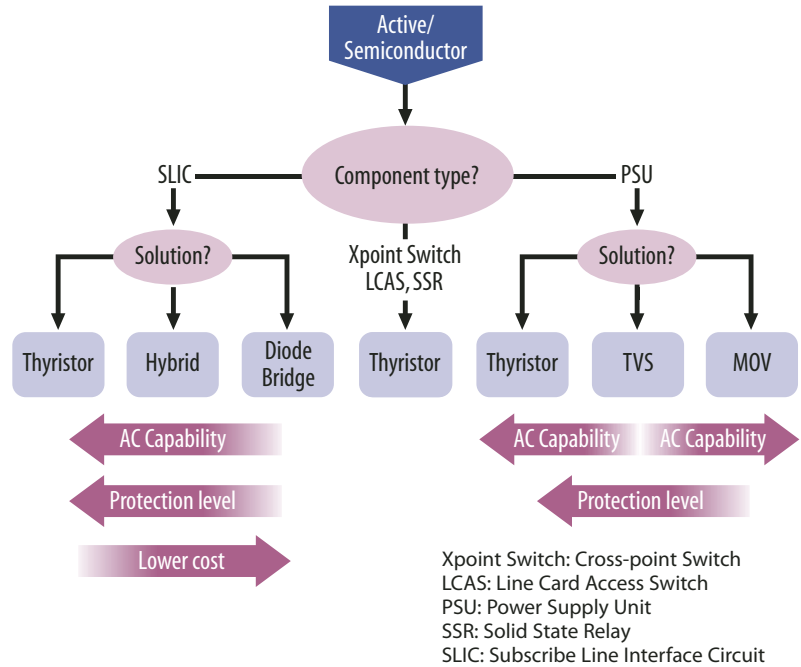

Note: The overvoltage protector may require the addition of AC overcurrent protection, such as a LFM, PTC thermistor or fuse.

Figure 7. Secondary protection of active components

Bourns® Products

Gas Discharge Tubes

Bourns offers the subminiature 3-electrode Mini-TRIGARD® GDT and the 2-electrode Mini-GDT. Combining small size with the industry's best impulse life, these products are ideal for high-density primary applications.

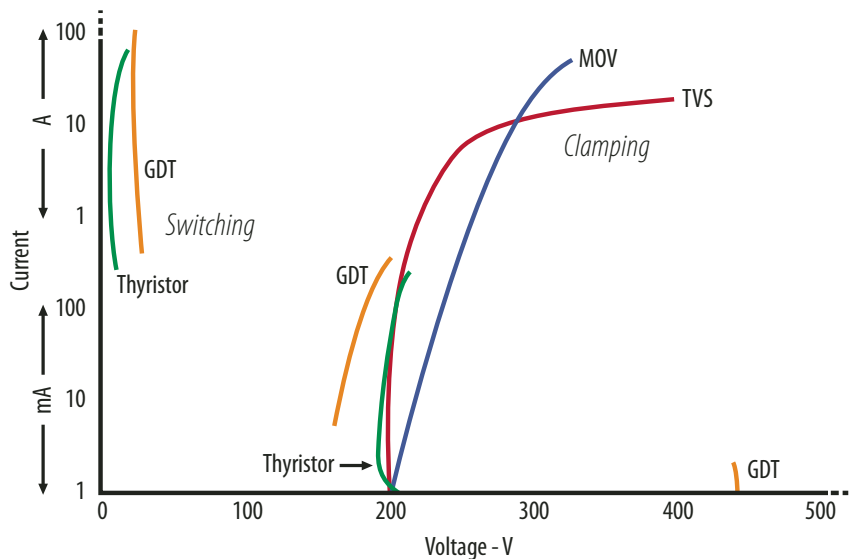

Figure 8. Overvoltage protectors feature very different V/I characteristics

Datasheet Tip

GDTs are available with Switch-Grade Fail-Short Device.

Standards Tip

UL Recognized GDTs are now available, requiring no BUG.

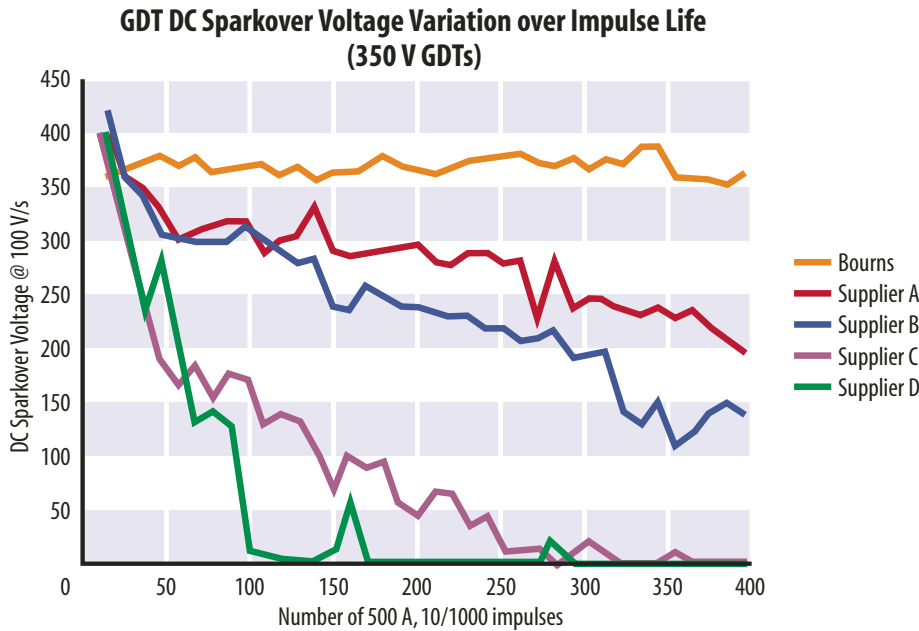

Figure 9. GDT behavior may deteriorate under real-world field conditions

Certain GDTs can suffer from venting or gas loss.

To ensure protection under these circumstances, an air Back Up Gap (BUG) has been used. BUGs themselves can be subject to moisture ingress or contamination, reducing their operating voltage, and leading to nuisance tripping. BUGs are also more sensitive to fast rising voltage surges, causing the BUG to operate instead of the GDT. All Bourns® GDTs are now UL approved for use without the need of a BUG, eliminating extra cost and improving reliability (see Figure 10).

Surge Current	Power Cross	dv/dt Sensitivity	di/dt Sensitivity	Typical Application
Several kA for 100 μ s	Several amps for seconds	Poor	None	Primary and secondary protection Exposed sites Sensitive equipment needs additional secondary protection Particularly suited to high speed digital lines

GDT protection capabilities

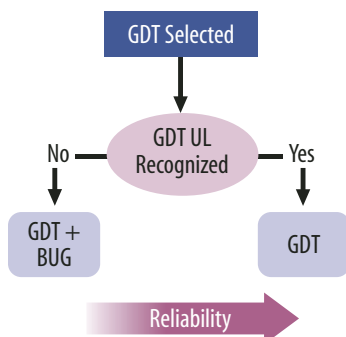

GDTs approved to UL497 optional test program for use without a back-up device are no longer required to use a BUG

Figure 10. Traditional GDT venting has required back-up protection

Thyristor-Based Devices

Thyristor-based devices initially clamp the line voltage, then switch to a low-voltage “On” state. After the surge, when the current drops below the “holding current,” the protector returns to its original high impedance state. The main benefits of thyristor protectors are lower voltage overshoot and an ability to handle moderate currents without a wear-out mechanism. The disadvantages of thyristor protectors are higher capacitance, which is a limitation in high-speed digital applications, and less tolerance of excessive current. Thyristor protectors can act either as secondary protection in conjunction with GDTs, or as primary protection for more controlled environments/ lower surge amplitudes. For protection in both voltage polarities, either a power diode or second thyristor may be integrated in

inverse parallel, creating versatile protection functions that may be used singly or in various combinations. The clamping voltage level of fixed voltage thyristors is set during the manufacturing process.

Gated thyristors have their protective level set by the voltage applied to the gate terminal.

Surge Current	Power Cross	dv/dt Sensitivity	di/dt Sensitivity	Typical Application
Several 100 A for 100 μ s	Several amps for seconds	Good	Poor	Primary or secondary protection Urban and some exposed sites Can protect sensitive equipment

Thyristor protection capabilities

Metal Oxide Varistors (MOVs)

A Metal Oxide Varistor (variable resistor) is a voltage dependent resistor whose current predominantly increases exponentially with increasing voltage. In clamping surges, the MOV absorbs a substantial amount of the surge energy. With a high thermal capacity, MOVs have high energy and current capability in a relatively small size. MOVs are

Datasheet Tip

When selecting operating voltage, remember that MOV residual voltage increases considerably at higher current.

extremely fast and low cost, but have high capacitance, a high, current-dependant clamping voltage, and are susceptible to wear. Typical MOV applications include general-purpose AC protection or low-cost analog telecom equipment such as basic telephones. When combined with a GDT, the speed of the MOV enables it to clamp the initial overshoot while the GDT begins to operate. Once the GDT fires, it limits the energy in the MOV, reducing the size of MOV required. Devices are available which integrate an MOV and GDT in a single package to simplify assembly and save space.

Surge Current	Power Cross	dv/dt Sensitivity	Typical Application
Several kA for 100 μ s	Dissipation limited	Good	Secondary protection Can protect non-sensitive equipment

MOV protection capabilities

Bourns® Products

TISP® Thyristor Surge Protectors

The TISP® family of thyristor-based devices includes an extensive range of single and multiple configurations in unidirectional and bidirectional formats, with fixed or gated operation.

Transient Voltage Suppressors

Transient Voltage Suppressor (TVS) diodes are sometimes called Zeners, Avalanche or Breakdown Diodes, and operate by rapidly moving from high impedance to a non-linear resistance characteristic that clamps surge voltages. TVS diodes provide a fast-acting and well-controlled clamping voltage which is much more precise than in an MOV, but they exhibit high capacitance and low energy capability, restricting the maximum surge current. Typically used for low power applications, their well-controlled voltage clamp enables the selection of protection voltages closer to the system voltage, providing tighter protection.

Surge Current	Power Cross	dv/dt Sensitivity	Typical Application
Low	Poor	None	Secondary protection Can protect sensitive equipment

TVS protection capabilities

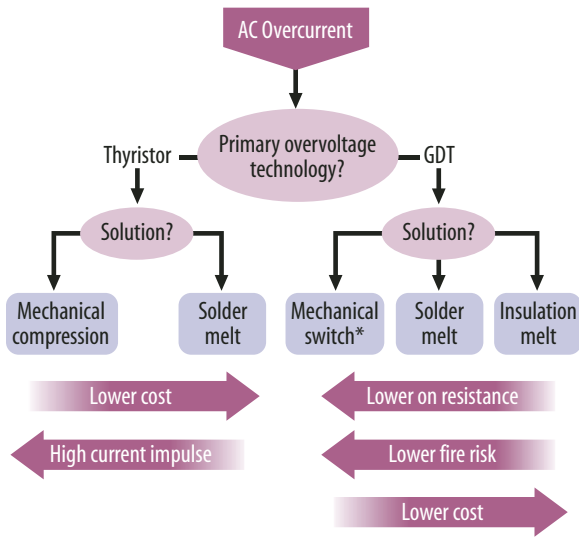

*Switch-Grade Fail-Short

Note: Protection against sneak currents requires the additional components

Figure 11. Selection of fail-short technology for Primary overvoltage protection

Technology Selection - Overcurrent Protectors

Current limiting devices (See Figures 11, 12) provide a slow response, and are primarily aimed at protection from surges lasting hundreds of milliseconds or more, including power induction or contact with AC power. By combining a fixed resistor in series with a resettable protector, an optimum balance of nominal resistance and operating time is obtained. The inherent resistance of certain overcurrent protectors can also be useful in coordination between primary and secondary overvoltage protection.

Reliability Tip

Hybrid devices incorporating resistors can improve performance.

Positive Temperature Coefficient (PTC) Thermistors

Heat generated by current flowing in a PTC thermistor causes a step function increase in resistance towards an open circuit, gradually returning close to its original value once the current drops below a threshold value. The stability of resistance value after surges over

	Nominal Ohms	Resistance Stability (with V and Temperature)	Change After Surge	Typical Application
Polymer PTC Thermistor	0.01 - 20	Good	10 - 20 %	CPE Equipment, e.g. Modem
Ceramic PTC Thermistor	10 - 50	R decreases with temperature and under impulse	Small	Balanced line, e.g. Line Card SLIC

Table 6. The two types of PTC thermistors have important differences

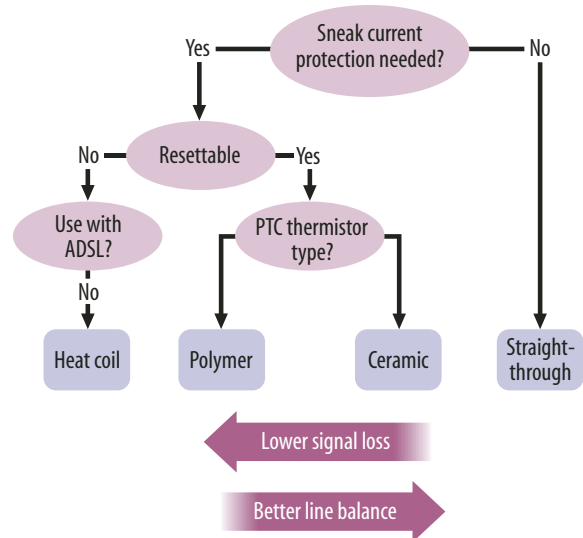

Figure 12. Sneak current technology selection

time is a key issue for preserving line balance. PTCs are commonly referred to as resettable fuses, and since low-level current faults are very common, automatically resettable protection can be

Reliability Tip

The stability of PTC thermistor resistance after operation can be critical for line balance.

particularly important. There are two types of PTC thermistors based on different underlying materials: Polymer and Ceramic. Generally the device cross-sectional area determines the surge current capability, and the device thickness determines the surge voltage capability.

Polymer PTC devices typically have a lower resistance than ceramic and are stable with respect to voltage and temperature. After experiencing a fault condition, a change in initial resistance may occur. (Resistance is measured one hour after the fault condition is removed and the resulting change in resistance compared to initial resistance is termed the R1 jump.)

In balanced systems with a PTC thermistor in each conductor, resistance change may degrade line balance. Including additional series resistance such as an LFR can reduce the effect of the R1 jump. In addition, some PTC thermistors are available in resistance bands to minimize R1 effects. Polymer types are also commonly used singly to protect CPE equipment.

Datasheet Tip

PTC thermistor and resistor hybrids can improve speed and line balance.

Ceramic PTC devices do not exhibit an R1 jump, and their higher resistance avoids the need for installing an additional LFR. While this reduces component count, the resistance does vary with applied voltage.

Since this change can be substantial (e.g. a decrease by a factor of about 3 at 1 kV), it is essential that any secondary overvoltage protection be correctly rated to handle the resulting surge current, which can be three times larger than predicted by the nominal resistance of the ceramic PTC. In a typical line card application, line balance is critical.

Bourns® Products

Multifuse® Resettable Fuses

Bourns offers an extensive range of polymer PTC devices in the Multifuse® resettable fuse product family, providing resettable overcurrent protection solutions.

Fuses

A fuse heats up during surges, and once the temperature of the element exceeds its melting point, the normal low resistance is converted to an open circuit. The low resistance of fuses is attractive for xDSL applications, but their operation is relatively imprecise and time-dependant. Once operated, they do not reset. Fuses also require additional resistance for primary coordination (see Application section).

Since overvoltage protection usually consists of establishing a low impedance path across the equipment input, overvoltage protection itself will cause high currents to flow. Although relatively slow

Safety Tip

Fuses offer a simple way to remove long-term faults, and potentially dangerous heat generation, but I-t coordination with other protection is vital.

acting, fuses can play a major safety role in removing longer term faults that would damage protection circuitry, thus reducing the size and cost of other protection elements. It is important to consider the I-t performance of the selected fuse, since even multiples of the rated current may not cause a fuse to rupture except after a significant delay. Coordination of this fuse behavior with the I-t performance of other protection is critical to ensuring that there is no combination of current-level and duration for which the protection is ineffective. By including structures intended to rupture under excess current conditions or separate components, it is also possible to produce hybrid fusible resistors.

Bourns® Products

Telefuse™ Telecom Fuses

Bourns has recently launched the B1250T/B0500T range of SMT power fault protection fuses.

Heat Coils

Heat coils are thermally activated mechanical devices connected in series with the line being protected, which divert current to ground. A series coil operates a parallel shunt contact, typically by melting a solder joint that is restraining a spring-loaded contact. When a current generates enough heat to melt the joint, the spring mechanically forces two contacts together, short-circuiting the line. Heat coils are ideal to protect against “sneak currents” that are too small to be caught by other methods. Their high inductance makes them unsuitable for digital lines. It is also possible to construct current interrupting heat coils which open the circuit as a result of overcurrent.

Bourns® Products

LPM Line Protection Modules

Bourns offers Line Feed Resistors combining matched resistor pairs plus thermal link fuses.

Line Feed Resistors

A Line Feed Resistor (LFR) is the most fundamental form of current protection, normally fabricated as a thick-film device on a ceramic substrate. With the ability to withstand high voltage impulses without breaking down, AC current interruption occurs when the high temperature developed by the resistor causes mechanical expansion stresses that result in the ceramic breaking open.

Low current power induction may not break the LFR open, creating long-term surface temperatures of more than 300 °C. To avoid heat damage to the PCB and adjacent components, maximum surface temperature can be limited to about 250 °C by incorporating a series thermal fuse link on the LFR. The link consists of a solder alloy that melts when high temperatures occur for periods of 10 seconds or more.

Along with the high precision needed for balanced lines, LFRs have significant flexibility to integrate additional resistors, multiple devices, or even different protection technology within a single component. One possible limitation is the need to dimension the LFR to handle the resistive dissipation under surge conditions. Along with combining multiple noninductive thick-film resistors on a single substrate to achieve matching to <1 %, a resistor can be combined with other devices to optimize their interaction with the overall protection design.

For example, a simple resistor is not ideal for protecting a wire, but combining a low value resistor with another overcurrent protector provides closer protection and less dissipation than either device can offer alone. Both functions can be integrated onto a single thick-film component using fusible elements, PTC thermistors, or thermal fuses. Similarly, more complex hybrids are available, adding surface mount components such as thyristor protectors, to produce coordinated sub-systems.

Thermal Switches

These switches are thermally activated, non-resetting mechanical devices mounted on a voltage-limiting device (normally a GDT). There are three common activation technologies: melting plastic insulator, melting solder pellet or a disconnect device.

Melting occurs as a result of the temperature rise of the voltage-limiting device's thermal overload condition when exposed to a continuous current flow. When the switch operates, it shorts out the voltage-limiting device, typically to ground, conducting the surge current previously flowing through the voltage limiting device.

A plastic-melting based switch consists of a spring with a plastic insulator that separates the spring contact from the metallic conductors of the voltage limiting device. When the plastic melts, the spring contacts both conductors and shorts out the voltage limiting device.

A solder-pellet-melting based switch consists of a spring mechanism that separates the line conductor(s) from the ground conductor by a solder pellet. In the event of a thermal overload condition, the solder pellet melts and allows the spring contacts to short the line and ground terminals of the voltage-limiting device.

A “Snap Action” switch typically uses a spring assembly that is held in the open position by a soldered standoff and will short out the voltage limiting device when its switching temperature is reached. When the soldered connection melts, the switch is released and shorts out the line and ground terminals of the voltage limited (Bourns US Patent #6,327,129).

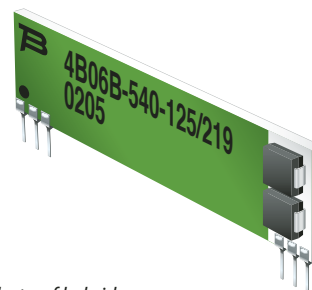

Figure 15. Photo of hybrid

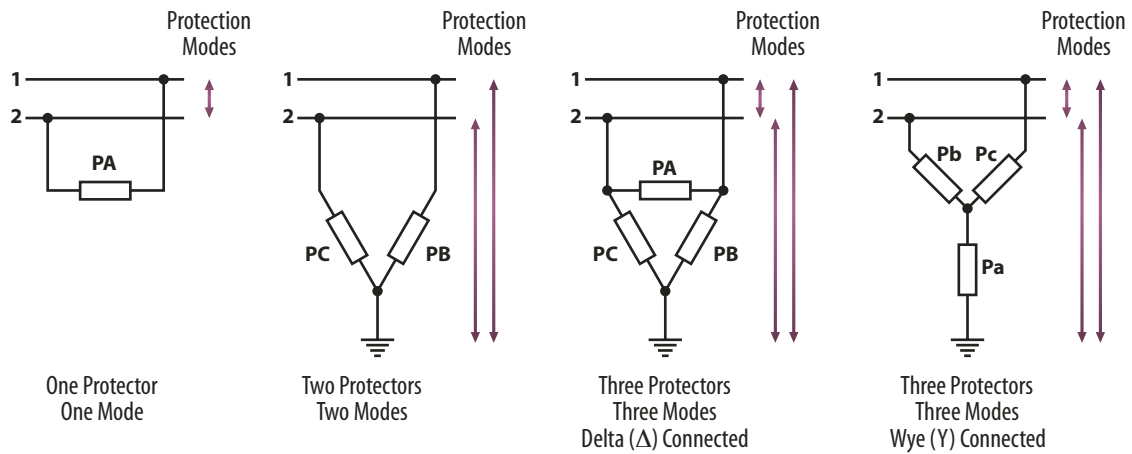

Figure 13. Matching the modes of protection to the application optimizes protection and cost

Modes of Overvoltage Protection

Insufficient protection reduces reliability, while excessive protection wastes money, making it vital to match the required protection level to the equipment or component being protected. One important aspect is the “modes” of protection.

Figure 13 illustrates that, for two wire systems, a single mode of operation protects against transverse (differential/metallic) voltages, but for three wire systems, the ground terminal provides opportunities to protect against both transverse and longitudinal (common-mode) surges. This offers a trade-off for items such as modems, where the provision of adequate insulation to ground for longitudinal voltages enables simple single mode/single device protection to be used.

Ground-referenced SLICs and LCAS ICs, however, require three-mode protection. Figure 14 illustrates how devices may be combined and coordinated to offer three-mode protection. The three-terminal GDT offers two modes of robust primary protection, while two PTC devices provide decoupling and coordination. The bidirectional thyristor provides the third mode of precise secondary voltage protection.

Technology Selection - Integrated Solutions

As emphasized earlier, no single technology provides ideal protection for all requirements. Combining more than one technology can often provide an attractive practical solution. Clearly the convenience

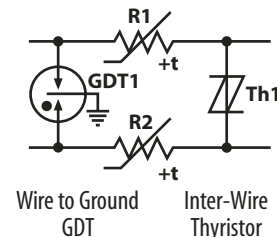

Figure 14. The modes of protection may be split between primary and secondary devices, with PTC thermistors ensuring coordination

of a single component/module combining multiple devices saves space and assembly cost while simplifying the design task (see Figure 15). In addition, some integrated modules provide performance and capabilities that cannot be achieved with separate discrete devices. In the next sections, multi-stage overvoltage protectors and a broader combination of overvoltage and overcurrent protection integrated line protection modules are presented.

Multi-Stage Protectors

When considering overvoltage protection (see Figure 4), combining a GDT with either a TVS or MOV clamping device can reduce the impulse voltage stress seen by downstream components. Although TVS devices are attractive, they often introduce too much capacitance. Typically, a GDT/MOV combination offers a better solution. Figure 16 illustrates the different behavior of GDTs, GDT/MOV hybrids and thyristor overvoltage protection for both 100 V/ μ s and 1000 V/ μ s impulse

waveforms. The GDT/MOV hybrid provides more consistent protection than a simple GDT, irrespective of the environment.

The low capacitance of the GDT/MOV hybrid also provides valuable characteristics for high frequency applications, enabling the protection of a wide range of copper-pair lines from POTS to VDSL and CAT5 100 Mb/s networks. All Bourns® GDT and GDT/MOV hybrid families are UL Recognized for use without a BUG, making them simple to use and saving valuable space.

Bourns® Products

GDT Gas Discharge Tubes

The Bourns® MSP® Multi-Stage Protector assembly combines MOV responsiveness with GDT robustness. Combined with our patented switch-grade fail-short device, it provides the optimum broadband network primary protection solution.

In addition to its superior clamping of fast rising transients, the MOV of the GDT/MOV assembly provides the function of a back up device without the well-known negative side effects of BUGs. Figure 11 demonstrates that a thermally operated current diverter is useful to protect the GDT from excessive heat dissipation under prolonged power cross conditions.

The best performance and lowest fire risk are provided by the thermal switch or switch-grade fail-short mechanism. GDT/MOV/fail-short overvoltage protectors effectively replace three components, providing maximum surge current capability from the GDT, low transient clamping characteristics and back up function from the MOV, and maximum safety from the switch-grade fail-short device.

Integrated Line Protection Modules

Integrating multiple protection elements on a single FR4 or ceramic substrate SIP reduces the PCB area used and increases the number of lines that can be fitted to each line card. Figure 17 outlines the key technologies available for such integrated assemblies

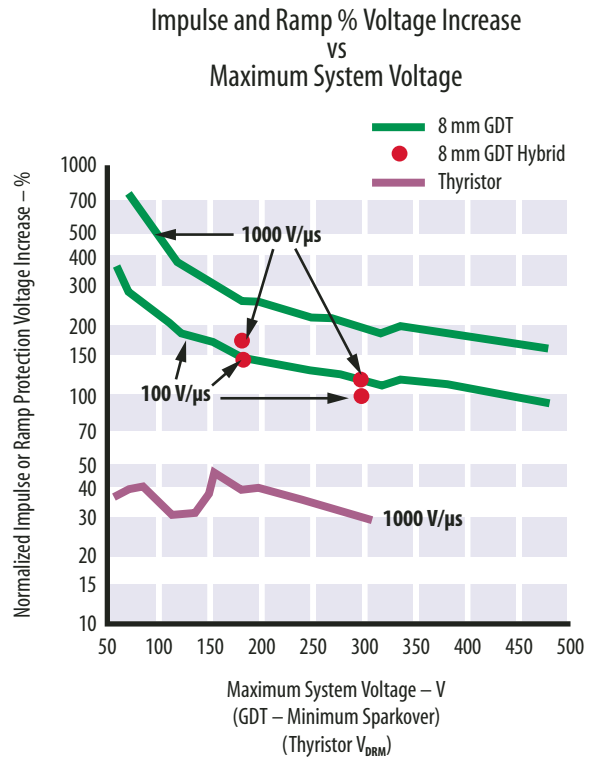

Figure 16. Each protection technology behaves differently under Impulse conditions

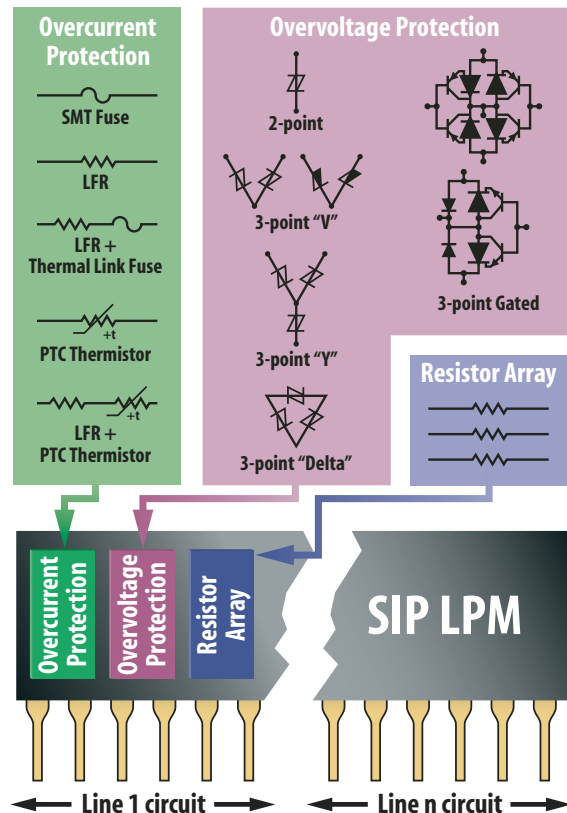

Figure 17. Multiple technologies may be integrated into a single, space-saving Line Protection Module

and introduces one new form of overcurrent protection. Thermal fuse link uses the heat from the LFR under continuous power induction to desolder a series link, which interrupts the induced current, avoiding thermal damage to the module, the line card or surrounding components. They are not practical as discrete devices because they use special structures built into the substrate. These integrated modules tend to be customized for each application, rather than off-the-shelf components.

Although PTC thermistors may be used alone, series connection with an LFR reduces peak currents and thereby allows smaller cross-section PTC thermistors to be used. The thermal coupling of an integrated module also ensures that the LFR heating further increases the rate of PTC thermistor temperature rise during AC faults causing faster low current tripping. The series LFR resistance will reduce the impulse current increase of ceramic thermistors and reduce the relative trip resistance change of polymer types.

It is worth noting that 10 mm SMT micro fuses are now available (e.g. Bourns® Telefuse™ fuse) with 600 V ratings to meet GR-1089-CORE, and UL 60950 safety requirements, and, dependent on the application, these may be fitted in either one or both signal lines. LFR technology can also be used to fabricate precision high voltage resistors on the same substrate for non-protection use, such as power ring feed resistors and bridges for off-hook detection, giving further cost and PCB space savings.

As seen in “Modes of overvoltage protection”, it is important to match the protection topology (typically thyristor based) to the equipment being protected, with simple single-mode, 2-point protection being suitable for Tip to Ring protection applications such as modem coupling capacitor protection. The two mode bidirectional 3-point “V” is a common configuration, protecting components connected between Tip or Ring and Ground, while

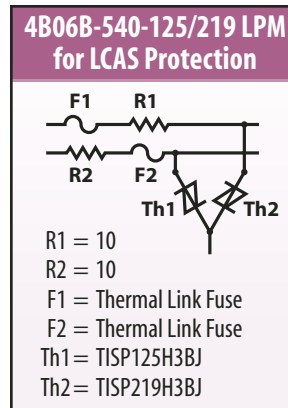

Figure 18. An example of an LPM integrated LCAS protection module

SLICs powered from negative supplies need only a uni-directional 3-point “V”. Three-mode “Y” or “Delta” 3-point protection is used where protection is needed both to ground and interwire.

Figure 18 illustrates an LCAS protection module, with ±125 V Tip protection, and

±219 V Ring protection in a 3-point “V” configuration, complete with LFRs and thermal link fuses.

As with discrete device solutions, gated thyristor protectors can be used to significantly reduce voltage stress for sensitive SLICs and current stress on downstream protection circuits. Once again the thermal coupling between a PTC thermistor and a heating element is beneficial. Heat from the thyristor speeds up thermistor tripping under power induction conditions. Further, the thyristor long-term temperature rise is constrained to the trip temperature of the thermistor, thereby limiting the maximum protection voltage under low AC conditions.

Each module can provide multiple circuits, protecting 2, 4 or 6 lines with a single module. The use of UL recognized components greatly eases both consistency of performance and UL recognition of the module. System-level design is simplified, because individual component variations are handled during the module design, enabling the module to be considered as a network specified to withstand defined stress levels at the input, while passing known stresses to downstream components.

Bourns® Products
LPM Line Protection Modules
 Bourns offers a variety of Line Protection Module (LPM) products, including custom options.

Telecommunication Standards and Recommendations Summary

Contents

1	Introduction	95
1.1	Test Circuits and Levels	95
1.2	Hazard indicators and wiring simulators	96
2	Equipment	97
2.1	Telcordia GR-1089-CORE, Issue 3, October 2002, <i>Electromagnetic Compatibility and Electrical Safety - Generic Criteria for Network Telecommunications Equipment</i>	97
2.2	Telcordia GR-3108-CORE, Issue 1 (in development), <i>Generic Requirements for Network Equipment in the Outside Plant (OSP) Telcordia Technologies Generic Requirements</i>	98
2.3	TIA-968-A-2002 with Addendums TIA-968-A-1 2003 and TIA-968-A-2 2004, <i>Telecommunications Telephone Terminal Equipment: Technical Requirements for Connection of Terminal Equipment to the Telephone Network (Formally known as “FCC Part 68”)</i>	98
2.4	UL 60950-1, April 2003, <i>Safety for Information Technology Equipment – Safety – Part 1: General Requirements</i>	98
2.5	UL 60950-21, November 2003, <i>Safety for Information Technology Equipment – Safety – Part 21: Remote Power Feeding</i>	99
2.6	UL 1459, 1999, <i>Standard for Telephone Equipment</i>	99
2.7	UL 2444, (in development), <i>Network Equipment Standard</i>	99
2.8	ITU-T Recommendation K.20 (07-2003), <i>Resistibility of telecommunication equipment installed in a telecommunications centre to overvoltages and overcurrents</i>	99
2.9	ITU-T Recommendation K.21 (07-2003), <i>Resistibility of telecommunication equipment installed in customer premises to overvoltages and overcurrents</i>	99
2.10	ITU-T Recommendation K.44 (07-2003), <i>Resistibility tests for telecommunication equipment exposed to overvoltages and overcurrents – Basic Recommendation</i>	99
2.11	ITU-T Recommendation K.45 (07-2003), <i>Resistibility of telecommunication equipment installed in the access and trunk networks to overvoltages and overcurrents</i>	103
2.12	ITU-T Recommendation K.50 (02/2000), <i>Safe limits of operating voltages and currents for telecommunication systems powered over the network</i>	103
2.13	ITU-T Recommendation K.51 (02/2000), <i>Safety criteria for telecommunication equipment</i>	103

2.14	IEC 61000-4-5 (2001-04), Ed. 1.1, <i>Electromagnetic compatibility (EMC)- Part 4-5: Testing and measurement techniques - Surge immunity test</i>	103
2.15	ETSI EN 300 386-1, (2003-05), <i>Electromagnetic compatibility and Radio spectrum Matters (ERM); Telecommunication network equipment; ElectroMagnetic Compatibility (EMC) requirements</i>	103
2.16	ETSI EN 300 386-2, (1997-12), <i>Electromagnetic compatibility and Radio spectrum Matters (ERM); Telecommunication network equipment; ElectroMagnetic Compatibility (EMC) requirements; Part 2: Product family standard</i>	103
3	Surge Protective Devices	103
3.1	GR-1361, Issue 2, September 1998, <i>Generic Requirements for Gas Tube Protector Units (GTPUS)</i>	103
3.2	GR-974-CORE, Issue 3, <i>Generic Requirements for Telecommunications Line Protector Units (TLPUs)</i>	104
3.3	UL 497, Edition 7 (April 2001), <i>Standard for Protectors for Paired Conductor Communications Circuits</i>	104
3.4	UL 497A, Edition 3 (March 2001) <i>Standard for Secondary Protectors for Communications Circuits</i>	104
3.5	UL 497B, Edition 4 (June 2004) <i>Standard for Protectors for Data Communication and Fire Alarm Circuits</i>	104
3.6	UL 497C Edition 2 (August 2001) <i>Standard for Protectors for Coaxial Communications Circuits</i>	104
3.7	IEEE Std C62.36-2000, <i>IEEE Standard Test Methods for Surge Protectors Used in Low-Voltage Data, Communications, and Signalling Circuits</i>	104
3.8	IEEE Std C62.64-1997, <i>IEEE Standard Specifications for Surge Protectors Used in Low-Voltage Data, Communications, and Signalling Circuits</i>	104
3.9	ITU-T Recommendation K.28 (03/1993), <i>Characteristics of semiconductor arrester assemblies for the protection of telecommunications installations</i>	104
3.10	IEC 61643-21 (2000-09), <i>Low voltage surge protective devices - Part 21: Surge protective devices connected to telecommunications and signalling networks - Performance requirements and testing methods</i>	104
3.11	ATIS T1.337-2004, <i>Requirements for Maximum Voltage, Current, and Power Levels in Network-Powered Transport Systems</i>	104
3.12	ATIS T1.338-2004, <i>Electrical Coordination of Primary and Secondary Surge Protective Devices for Use in Telecommunications Circuits</i>	105

4	Surge Protective Components	105
4.1	REA Bulletin 345-83, <i>Specification for Gas Tube Surge Arrestor, RUS PE-80</i>	105
4.2	ITU-T Recommendation K.12 (02/2000), <i>Characteristics of gas discharge tubes for the protection of telecommunications installations</i>	105
4.3	IEEE Std C62.3x <i>Series of Test Specifications For Surge Protective Components</i>	105
4.3.1	IEEE Std C62.31-1987 (under revision), <i>IEEE Standard Test Specifications For Gas-Tube Surge-protective Devices</i>	105
4.3.2	IEEE Std C62.32-2004 <i>IEEE standard test specifications for low-voltage air gap surge-protective devices (excluding valve and expulsion type devices)</i>	105
4.3.3	IEEE Std C62.33-1982 <i>IEEE standard test specifications for varistor surge-protective devices</i>	105
4.3.4	IEEE Std C62.35-1987 <i>IEEE standard test specifications for avalanche junction semiconductor surge protective devices</i>	105
4.3.5	IEEE Std C62.37-1996 <i>IEEE standard test specification for thyristor diode surge protective devices</i> ...	105
4.4	IEC 61643-3x1 <i>Series of test specifications for low-voltage surge protective components</i>	105
4.4.1	IEC 61643-311 (2001-10), Ed. 1.0, <i>Components for low voltage surge protective devices - Part 311: Specification for gas discharge tubes (GDT)</i>	105
4.4.2	IEC 61643-321 (2001-12) Ed. 1.0, <i>Components for low voltage surge protective devices - Part 321: Specifications for avalanche breakdown diode (ABD)</i>	105
4.4.3	IEC 61643-331 (2003-05) Ed. 1.0, <i>Components for low voltage surge protective devices - Part 331: Specification for metal oxide varistors (MOV)</i>	105
4.4.4	IEC 61643-341 (2001-11) Ed. 1.0, <i>Components for low voltage surge protective devices - Part 341: Specification for thyristor surge suppressors (TSS)</i>	105

1 Introduction

This document summarises the common telecommunication protection device and equipment standards. To minimise service loss and user safety hazards, service providers and regulators mandate that equipment and devices comply with specific standards or recommendations. This section summarises telecommunications component and port surge tests in the North American documents from Telcordia (GR), Underwriters Laboratories (UL), Institute of Electrical and Electronics Engineers (IEEE) and Telecommunications Industry Association (TIA). International documents covered come from the International Telecommunication Union Telecommunication Standardization Sector (ITU-T) and the International Electrotechnical Commission (IEC). As international trade, travel and communications increase, international standards enable products to be sold and work worldwide. Standards are constantly evolving, so it is important to verify the material here against the latest copies of the relevant documents. The European documents covered are either EN versions of IEC standards or from the European Telecommunications Standards Institute (ETSI).

1.1 Test Circuits and Levels

Lightning and power fault events can induce longitudinal surges in the telecommunication line and Figure 1 shows how longitudinal (port to ground) surge testing is done. Depending on the test intent additional items such as primary protection, wiring simulation and the decoupling of other ports may be added in these test circuits.

Asynchronous operation of upstream protection grounds one line conductor and converts a longitudinal surge into a transverse surge. Figure 2 shows the transverse (metallic or differential) surge test circuit. The number of transverse test configurations is the same as the number of wires. A twisted-pair should have two tests, one applied to the Ring conductor and the other applied to the Tip conductor. However, if the circuit is symmetrical, only one proving test needs be done.

When the ground has high resistance or is not connected, the incoming surge enters the equipment on one port and exits at another port – a port-to-port surge. Figure 3 shows how port-to-port testing is done.

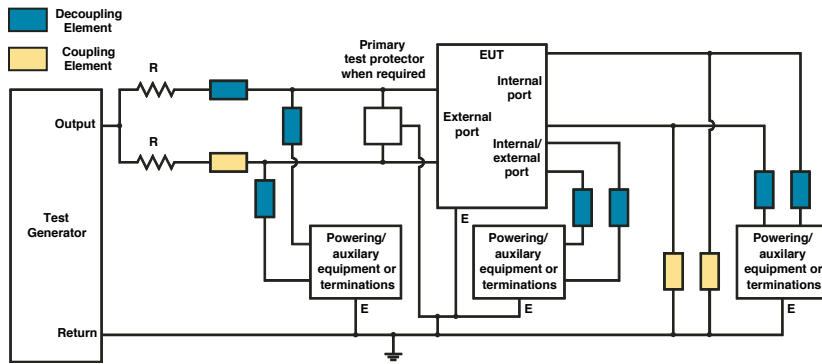

Figure 1. Longitudinal surge test circuit

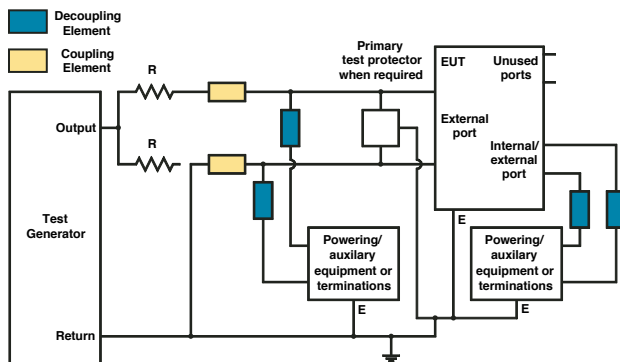

Figure 2. Transverse surge test circuit

The surge threats are higher for the exposed external cables than cables just internal to the building. Figure 4 shows port testing for shielded and unshielded internal cables. GR-1089-CORE excludes internal port testing, if the shielded cable is grounded at both ends.

The maximum test levels applied are typically in three areas; basic withstand, a higher (enhanced) level withstand for adverse environments and an excessive level to investigate possible safety hazards. Step testing is done at levels up to the maximum specified to verify there are no blind spots in the equipment performance. The equipment must be functional after withstand testing (criterion A or “first level”) and shall not create hazard from safety testing (criterion B or “second level”).

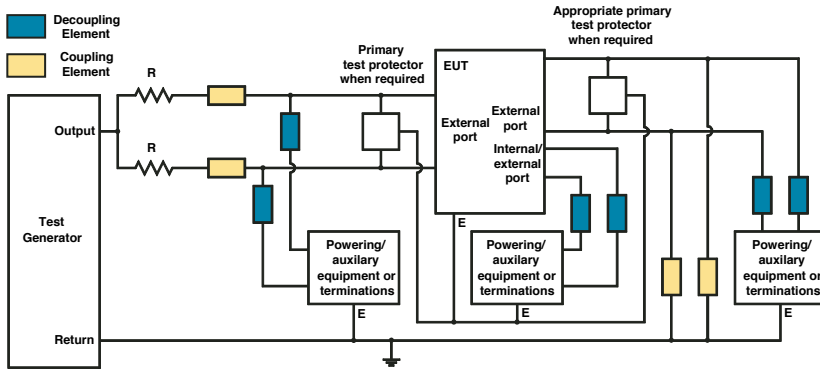

Figure 3. Port to port surge test circuit

1.2 Hazard indicators and wiring simulators

The condition of cheesecloth wrapped around the item under test checks for potential user hazards. After safety testing, hazards are indicated by cheesecloth that is charred burnt or perforated (GR-1089-CORE only). Wiring simulations in a test circuit check that the equipment feed cable will overheat. The equipment must interrupt or reduce the AC fault current before the simulator operates or is judged to overheat. Because of different cabling practices and simulation options, there are more wiring simulator options than standards that use them. Figure 5 shows a selection of simulators; graphical, mathematical, fuse (shown at 80 % of typical) and single wire, together with their referenced standards.

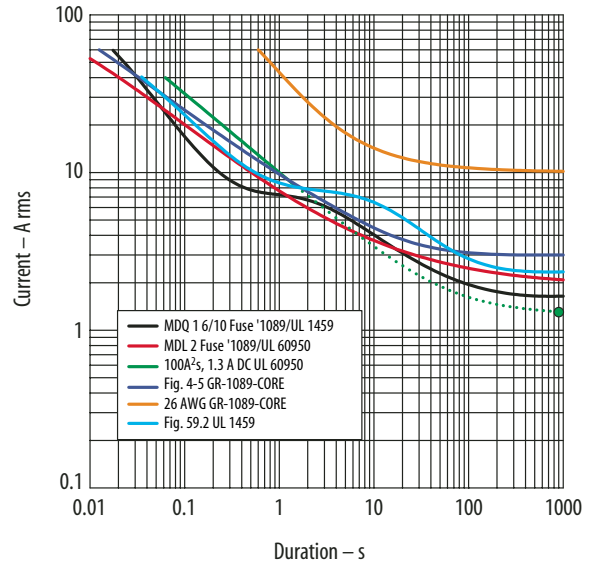

Figure 5. Wiring simulators

2 Equipment

2.1 Telcordia GR-1089-CORE, Issue 3, October 2002

Electromagnetic Compatibility and Electrical Safety - Generic Criteria for Network Telecommunications Equipment

AC and lightning surge test circuits and performance levels for the external and internal line ports of network equipment. External port feed cable

overheating and primary-equipment coordination tests are included. Test summaries for twisted-pair cables are shown in tables one through three. Further material on GR-1089-CORE, Issue 3 is in the article “The New GR-1089-CORE” Compliance Engineering, 2003 Annual Reference Guide: pp 103-113.

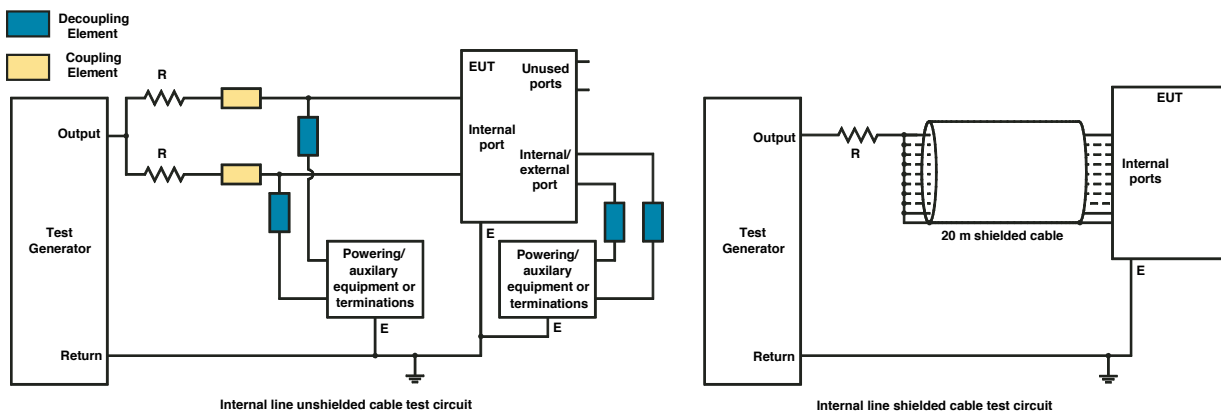

Figure 4. Internal cable port test circuits

GR-1089-CORE Table #	Test #	Min. Peak Open Circuit Conductor Voltage (V)	Min. Peak Short-Circuit Conductor Current (A)	Waveshape	Repetitions Each Polarity	Test Connection	Test Type	Port	Primary
4-2 ³	1	600	100	<10/>1000	25	Longitudinal & Transverse	First Level Withstand	External	Removed
	2	1000	100	<10/>360	25				
	3 ¹	1000	100	<10/>1000	25				
	4	2500	500	<2/>10 ²	10	Longitudinal			
	5 ⁵	1000	25	<10/>360	5	Longitudinal up to 12 pairs			
4-3 ⁴	1	400-2000	0-100	<10/>1000	10	Longitudinal & Transverse	Coordination		
4-4 ³	1	5000	500	<2/>10 ²	1	Longitudinal	Second Level Safety		
4-5 ⁶	1	800	100	<2/>10 ²	1	Transverse	First Level Withstand	Intra-building	
	2	1500	100	<2/>10 ²	1	Longitudinal			

Notes:

- Test 3 replaces tests 1 and 2.
- A 1.2/50, 8/20 combination waveshape of the same peak current (but increased duration) may be used as an alternative.
- For equipment with voltage limiters, tests must also be done at a voltage level just below the limiter threshold.
- Becomes an objective January 2005 and a requirement in January 2006. Besides GR-1089-CORE, Issue 3, further information on this test is contained in "Electrical Coordination of Primary and Secondary Surge Protective Devices for Use in Telecommunications Circuits" T1.333-2004 and "The New GR-1089-CORE" Compliance Engineering, 2003 Annual Reference Guide: pp 103-113.
- Not applicable for single port equipment.
- Not applied to ports with shielded cables that have the shield grounded at both ends.

Table 1. GR-1089-CORE impulse tests

GR-1089-CORE Table # ¹	Test #	Open-Circuit Conductor Voltage (V rms)	Short-Circuit Conductor Current (A rms)	Duration (s)	Applications	Test Connection	Test Type	Port	Primary
4-6	1 ²	50	0.33	900	1	Longitudinal & Transverse	First Level Withstand	External	Removed
	2 ²	100	0.17	900	1				
	3 ²	200, 400 & 600	1 @ 600 V rms	1	60	Longitudinal			Fitted
	4	1000	1	1	60				
	5	Inductively coup led test circuit 1089 Fig. 4-4		5	60				
	6	600	0.5	30	1	Longitudinal & Transverse			Removed
	7	440	2.2	2	5				
	8	600	3	1.1	5	Longitudinal			Fitted
	9	1000	5	0.4	5				
4-7 ^{2,3} 4-8 ^{2,4}	1	120, 277	25	900	1	Longitudinal & Transverse	Second Level Safety	External	Removed
	2	600	60	5	1				
	3	600	7	5	1				
	4	100-600	2.2 @ 600 V rms	900	1				
	5	Inductively coup led test circuit 1089 Fig. 4-4		900	1	Longitudinal			

Notes:

- AC sources are 50 Hz or 60 Hz, sinusoidal.
- For equipment with a voltage limiter or current limiter, tests must also be done at a level just below the limiter threshold.
- For non-customer-premise equipment the wiring simulation used for all tests may be GR-1089-CORE Figure 4-5, an MDL 2 fuse or an MDQ 1 6/10 fuse.
- For customer-premise equipment the wiring simulation used for all tests may be GR-1089-CORE Figure 4-5, an MDL 2 fuse, an MDQ 1 6/10 fuse or a 26 AWG wire, if such wire or coarser is specified for installation.

Table 2. GR-1089-CORE AC power fault tests

GR-1089-CORE Clause #	Open-Circuit Conductor Voltage (V rms)	Short-Circuit Conductor Current (A rms)	Duration (s)	Applications	Test Connection	Test Type	Port	Primary
4.6.11 ² 4.6.14 ³	600	30, 25, 20, 12.5, 10, 7, 5, 3.75, 3, 2.6 & 2.2	900	1	Longitudinal & Transverse	Second Level Safety	External	Removed
4.6.17 ^{4,5}	120	25					Internal	N/A

Notes:

1. AC sources are 50 Hz or 60 Hz, sinusoidal.
2. For current-limiting protector tests of non-customer-premise equipment, the wiring simulation used may be GR-1089-CORE Figure 4-5, and MDL fuse or an MDQ 1 6/10 fuse.
3. For fusing coordination tests of network equipment to be located at the customer premises, the wiring simulation used may be GR-1089-CORE Figure 4-5, and MDL 2 fuse or a 26 AWG wire, if such wire or coarser is specified for installation.
4. Only for network equipment to be located at the customer premises.
5. For second-level intra-building port testing of customer premise equipment, the wiring simulation used may be GR-1089-CORE Figure 4-5, an MDL 2 fuse or a MDQ 1 6/10 fuse.

Table 3. GR-1089-CORE AC current-limiter and fusing tests

Surge Type	Minimum Peak Open-Circuit Conductor Voltage (V)	Voltage Waveshape	Minimum Peak Short-Circuit Conductor Current (A)	Current Waveshape	Test Connection	Port
A ¹	800	<10/>560	100	<10/>560	Transverse	External
	1500	<10/>160	200	<10/>160	Longitudinal	
B ²	1000	9/720	25	5/320	Transverse	
	1500	9/720	27.3 ³	4/245 ³	Longitudinal	

Notes:

1. Equipment may fail, but not in a Ring-Tip short-circuit mode.
2. Equipment must be operational after these withstand tests.
3. These values are for both Ring and Tip outputs grounded. T1-968-A quotes for only one conductor grounded, giving 37.5 A and 5/320.

Table 4. TIA-968-A-2002 Lightning surge tests

2.2 Telcordia GR-3108-CORE, Issue 1 (in development),

Generic Requirements for Network Equipment in the Outside Plant (OSP) Telcordia Technologies

Generic Requirements

Defines OSP environmental performance requirements which can be used during GR-1089-CORE testing.

2.3 TIA-968-A-2002 with Addendums TIA-968-A-1 2003 and TIA-968-A-2 2004,

Telecommunications Telephone Terminal Equipment: Technical Requirements for Connection of Terminal Equipment to the Telephone Network (Formally known as "FCC Part 68")

Lightning surge test circuits and performance levels for the external line ports of equipment installed at the customer premise. Power fault and safety

requirements will come from UL 60950-1 compliance. Table 4 summarizes the impulse test conditions of this standard.

2.4 UL 60950-1, April 2003

Safety for Information Technology Equipment – Safety – Part 1: General Requirements

AC and lightning surge test circuits and safety performance for the external line ports of network equipment. External port feed cable-overheating tests are included. Table 6 summarizes the AC power fault tests and Figure 6 shows the overvoltage flow chart for product approval.

UL 60950-1 Clause # ¹	Test #	Open-Circuit Conductor Voltage (V rms)	Short-Circuit Conductor Current (A rms)	Duration (s)	Test Connection	Test Type	Port	Wiring Simulation
NAC.3.3 ²	M-1, L-1 and F1	600	40	1.5	Longitudinal & Transverse	Safety, No Ignition or Charring of the Equipment Cheesecloth Indicator	External	Y ³
	M-2, L-2 and F2	600	7	5				N
	M-3, L-3 and F3	600	2.2	1800				
	M-3A, L-3A and F3A	600	<2.2 ³	1800				
	M-4, L-4 and F4	<600 ³	<2.2 ³	1800				
	L-5	120	25	1800	Longitudinal	Y ³		

Notes:

- AC sources are 50 Hz or 60 Hz, sinusoidal.
- "M" tests are differential (metallic or transverse) mode tests. "L" tests are common (longitudinal) mode tests. "F" tests are 4-wire tests, one pair is longitudinally tested and one port terminal of the other pair is grounded.
- Used when a minimum 26 AWG telecommunications line cord is not provided or specified. Simulator may be a 50 mm length of 0.2 mm (No. 32 AWG) solid copper wire or an MDL-2 fuse. For M-1, L-1 and F-4 an i^2t measurement of less than 100 A²s can be used.
- Test 3A is done when the current in test 3 is interrupted. The applied circuit current must be set to be just below the operating current level of the equipment current limiter for the test duration.
- Test 4A is done when the equipment voltage limiter, rated at 285 V peak or more, operated during tests 3 or 3A. The equipment voltage and current levels are set at a level just below the voltage and current limiter threshold levels.

Table 6. UL 60950-1 AC power fault tests

2.5 UL 60950-21, November 2003

Safety for Information Technology Equipment – Safety – Part 21: Remote Power Feeding

Sets the safety performance levels of remote voltage (RFT-V) or current (RFT-C) power feeds to equipment.

2.6 UL 1459, 1999

Standard for Telephone Equipment

AC surge test circuits and safety performance for the external line ports of equipment connected to the network. External port feed cable-overheating tests are included (NB maximum current levels are lower than UL-60950-1).

2.7 UL 2444, (in development)

Network Equipment Standard

This is a safety-listing standard based on GR-1089-CORE, UL 1459 and UL 60950-1.

2.8 ITU-T Recommendation K.20 (07-2003)

Resistibility of telecommunication equipment installed in a telecommunications centre to overvoltages and overcurrents

AC and lightning surge performance levels for the

external and internal line ports of equipment installed at telecommunications centres. Two surge withstand levels are specified, basic and enhanced. Primary-equipment coordination tests are included.

2.9 ITU-T Recommendation K.21 (07-2003)

Resistibility of telecommunication equipment installed in customer premises to overvoltages and overcurrents

AC and lightning surge performance levels for the external and internal line ports of equipment installed at the customer premise. Two surge withstand levels are specified, basic and enhanced. Primary-equipment coordination tests are included.

2.10 ITU-T Recommendation K.44 (07-2003)

Resistibility tests for telecommunication equipment exposed to overvoltages and overcurrents—Basic Recommendation

AC and lightning surge test circuits to be used for K.20, K.21 and K.45 performance evaluations. Tables 7 through to 9 summarise the tests and levels for paired conductor ports in K.20, K.21 and K.45.

Copyright for these tables belongs to Canon Communications LCC and they originally appeared in "The 2004 ITU-T Telecommunication Equipment Resistibility Recommendations" Compliance Engineering, 2004 Annual Reference Guide: 117-124. A further article on ITU-T testing is "The New ITU-T Telecommunication Equipment Resistibility Recommendations" Compliance Engineering 19, no. 1 (2002): 30-37.

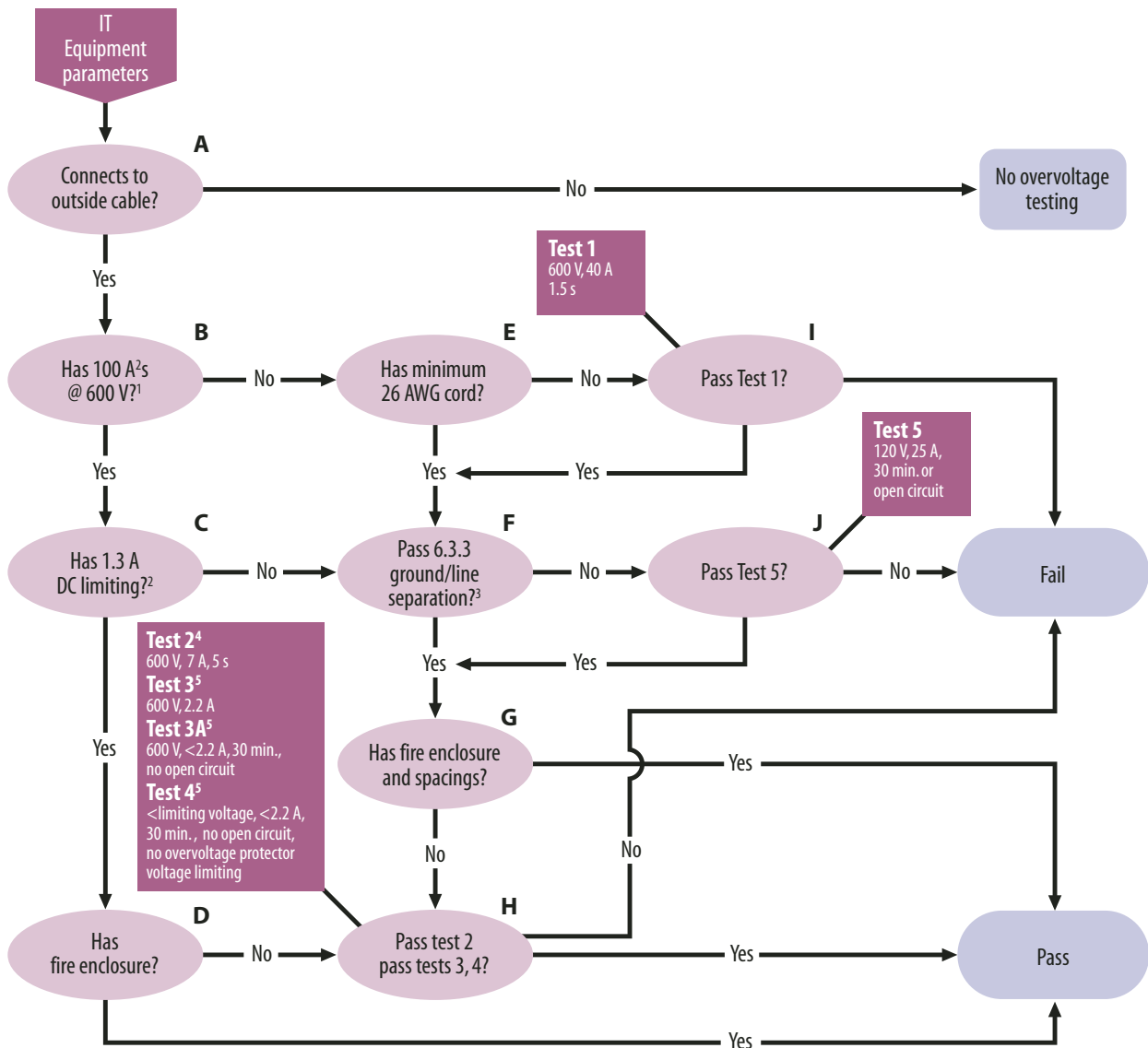

Notes:

1. Overcurrent protector I_t must be lower than any other equipment element which carries the same current.
2. UL states a fuse with a 1 A or less rating meets the 1.3 A criterion.
3. Pass for 120 V A.C. between telecommunications line and ground current <10 mA.
4. Test 2 not required if the equipment D.C. breaking is 1.3 A or less. See Note 2.
5. Tests 3 and 4 not required for equipment with less than 1000 m of outside cable.

Figure 6. UL 60950-1 Overvoltage flow chart
 UL 60950-1 (04/2003)
 Information Technology Equipment – Safety – Part 1: General Requirements
 Clause 6.4 – Protection against overvoltage from power line crosses
 Figure 6C – Overvoltage flowchart
 Annex NAC (normative) – Power line crosses

Pass Criteria	Test 1	Test 2	Test 3	Test 3A	Test 4	Test 5
No equipment cheesecloth charring	✓	✓	✓	✓	✓	✓
Insulation OK	✓	✓	✓	✓	✓	✓
50 mm of 32 AWG wire or MDL-2 A fuse OK	✓					✓
I _t < 100 A ² s @ 600 V rms AC	✓					

Ports Waveshape (Notes) No. of Tests	Test #	Lighting Test Description	Basic Test Levels			Enhanced Test Levels			Primary Protection	Acceptance Criteria
			K.20	K.45	K.21	K.20	K.45	K.21		
Single 10/700 Voltage (Note 1) +5, -5	2.1.1.a	Inherent Transverse	1.0 kV, R = 25 Ω	1.5 kV, R = 25 Ω			None	A		
	2.1.1.b	Inherent Port to Earth	1.0 kV, R = 25 Ω	1.5 kV, R = 25 Ω		6 kV, R = 25 Ω (Note 2)				
	2.1.1.c	Inherent Port to External Port	—	1.5 kV, R = 25 Ω	(Note 7)				1.5 kV, R = 25 Ω	
Single 10/700 Voltage (Notes 3 & 4) +5, -5	2.1.2.a	Coordination Transverse	4 kV, R = 25 Ω			6 kV, R = 25 Ω	Yes Special Protector	A If Fitted, Special Protector Must Operate at Maximum Test Level		
	2.1.2.b	Coordination Port to Earth	4 kV, R = 25 Ω							
	2.1.2.c	Coordination Port to External Port	—	4 kV, R = 25 Ω	(Note 7)				4 kV, R = 25 Ω	
Multiple 10/700 Voltage (Notes 1 & 5) +5, -5	2.1.3a	Inherent Port to Earth	1.5 kV, R = 25 Ω			None	A			
	2.1.3b	Inherent Port to External Port	—	1.5 kV, R = 25 Ω	(Note 7)			1.5 kV, R = 25 Ω		
Multiple 10/700 Voltage (Notes 3, 4 & 5) +5, -5	2.1.4a	Coordination Port to Earth	4 kV, R = 25 Ω		6 kV, R = 25 Ω		Yes Agreed Protector	A		
	2.1.4b	Coordination Port to External Port	—	4 kV, R = 25 Ω	(Note 7)	6 kV, R = 25 Ω				
Single 8/20 Current (Note 6) +5, -5	2.1.5a	Port to Earth	1 kA/wire, R = 0		5 kA/wire, R = 0		None	A		
	2.1.5b	Port to External Port	—	1 kA/wire, R = 0	(Note 7)	5 kA/wire, R = 0				
Multiple 8/20 Current (Note 5 and 6) +5, -5	2.1.6a	Port to Earth	1 kA/wire, R = 0, 6 kA Max. Return		5 kA/wire, R = 0, 30 kA Max. Return		None	A		
	2.1.6b	Port to External Port	—	1 kA/wire, R = 0, 6 kA Max. Return	(Note 7)	5 kA/wire, R = 0, 30 kA Max. Return				

Test levels are given as the maximum D.C. charge voltage of the surge generator or current delivered to a tested equipment terminal and R is the value of current limit resistor. The current limit resistor, R, may be internal or external to the generator.

Notes

- Not applied to equipment designed to be always used with primary protection. For K.20, K.21 and Test 2.1.1 there must be operator agreement and the an appropriate internal port test applied (see Table III).
- Equipment with conductor to ground SPDs shall be tested at 1.5 kV instead of 6 kV. Insulated case equipment has 6 kV insulation test.
- With network operator and manufacturer agreement, equipment containing high current carrying components which eliminate the need for primary protection shall be tested without primary protection. Testing shall done with highest voltage high current carrying components.
- Equipment, which agreed not to use primary protection, shall be tested without primary protection. K.44, 3.1.4
- Simultaneously applied to all ports. When the equipment has more than 8 ports, only 8 of the ports are tested.
- Only for equipment, which contains high current carrying components that eliminate the need for primary protection.
- Apply K.45 port to external port test at the K.20 enhanced level for small telecommunication centres with less than 250 lines.

Table 7. Lightning tests for ports connected to external symmetric-pair cables

Ports Frequency (Notes) No. of Tests	Test #	Power Test Description	Basic Test Levels			Enhanced Test Levels			Primary Protection	Acceptance Criteria
			K.20	K.45	K.21	K.20	K.45	K.21		
Single 16-2/3 Hz, or 50 Hz or 60 Hz (Note 1) 5	2.2.1.a	Induction Inherent Transverse	$I^2t = 0.2 \text{ A}^2\text{s};$ $V = 600 \text{ V rms max.};$ $R = 600 \Omega; t = 0.2 \text{ s}$						None	A
	2.2.1.b	Induction Inherent Port to Earth	$I^2t = 0.2 \text{ A}^2\text{s};$ $V = 600 \text{ V rms max.};$ $R = 600 \Omega; t = 0.2 \text{ s}$							
	2.2.1.c	Induction Inherent Port to External Port	—	$I^2t = 0.2 \text{ A}^2\text{s};$ $V = 600 \text{ V rms max.};$ $R = 600 \Omega; t = 0.2 \text{ s}$	(Note 6)	$I^2t = 0.2 \text{ A}^2\text{s};$ $V = 600 \text{ V rms max.};$ $R = 600 \Omega; t = 0.2 \text{ s}$				
Single 16-2/3 Hz, or 50 Hz or 60 Hz (Note 2) 5 at each test level	2.2.2.a	Induction Coordination Transverse	$I^2t = 1.0 \text{ A}^2\text{s};$ $V = 600 \text{ V rms max.};$ $R = 600 \Omega; t = 1.0 \text{ s};$ (Note 3)			$I^2t = 10 \text{ A}^2\text{s};$ $450 \text{ V rms} \leq v \leq 1500 \text{ V rms};$ $R = 200 \Omega; 0.18 \text{ s} \leq t \leq 2.0 \text{ s};$ $t = (400\,000)/(v)^2;$ (Note 4)			Yes Special (Agreed Primary) Test Protector	A
	2.2.2.b	Induction Coordination Port to Earth	$I^2t = 1.0 \text{ A}^2\text{s};$ $V = 600 \text{ V rms max.};$ $R = 600 \Omega; t = 1.0 \text{ s};$ (Note 3)			$I^2t = 10 \text{ A}^2\text{s};$ $450 \text{ V} \leq v \leq 1500 \text{ V rms};$ $R = 200 \Omega; 0.18 \text{ s} \leq t \leq 2.0 \text{ s};$ $t = (400\,000)/(v)^2;$ (Note 4)				
	2.2.2.c	Induction Coordination Port to External Port	—	$I^2t = 1.0 \text{ A}^2\text{s};$ $V = 600 \text{ V rms max.};$ $R = 600 \Omega; t = 1.0 \text{ s};$ (Note 3)	(Note 6)	$I^2t = 10 \text{ A}^2\text{s};$ $450 \text{ V} \leq v \leq 1500 \text{ V rms};$ $R = 200 \Omega;$ $0.18 \text{ s} \leq t \leq 2.0 \text{ s};$ $t = (400\,000)/(v)^2;$ (Note 4)				
Single 50 Hz or 60 Hz (Note 5) 1 set	2.3.1.a	Contact Inherent Transverse	$V = 230 \text{ V rms};$ $R = 10 \Omega, 20 \Omega, 40 \Omega, 80 \Omega, 160 \Omega, 300 \Omega, 600 \Omega, \text{ and } 1000 \Omega;$ $t = 900 \text{ s for each resistor value}$						None	B, Except A for Enhanced Level Testing using $R = 160 \Omega,$ 300Ω and 600Ω
	2.3.1.b	Contact Inherent Port to Earth	$V = 230 \text{ V rms};$ $R = 10 \Omega, 20 \Omega, 40 \Omega, 80 \Omega, 160 \Omega, 300 \Omega, 600 \Omega, \text{ and } 1000 \Omega;$ $t = 900 \text{ s for each resistor value}$							
	2.3.1.c	Contact Inherent Port to External Port	—	$V = 230 \text{ V rms};$ $R = 10 \Omega, 20 \Omega, 40 \Omega,$ $80 \Omega, 160 \Omega, 300 \Omega,$ $600 \Omega, \text{ and } 1000 \Omega;$ $t = 900 \text{ s for each}$ resistor value	(Note 6)	$V = 230 \text{ V rms};$ $R = 10 \Omega, 20 \Omega, 40 \Omega,$ $80 \Omega, 160 \Omega, 300 \Omega,$ $600 \Omega, \text{ and } 1000 \Omega;$ $t = 900 \text{ s for each}$ resistor value				

Test levels are given as the maximum or range of generator open circuit A.C. voltages, A.C. frequency, test time and R is the value or values of current limit resistor.

Notes

1. Not applied to equipment designs to be always used with primary protection. K.20 and K.21 equipment also needs operator agreement.
2. Equipment, containing high current carrying components, which eliminate the need for primary protection shall be tested without primary protection. Equipment shall use special worst-case high current carrying components.
3. To suit local conditions a voltage of $300 \text{ V rms} \leq V \leq 600 \text{ V rms}$ and time $t \leq 1.0 \text{ s}$ may be specified. The series current limit resistance shall then be $R = V(t)^{0.5}$
4. All voltage-time combinations shall be tested as defined by the time equation.
5. Equipment, which is always used with primary protection, shall be tested with special agreed primary protector.
6. Apply K.45 port to external port test at the K.20 enhanced level for small telecommunication centres with less than 250 lines.

Table 8. AC tests for ports connected to external symmetric-pair cables

Ports Generator (Notes) No. of Tests	Test #	Lighting Test Description	Basic Test Levels			Enhanced Test Levels			Primary Protection	Acceptance Criteria
			K.20	K.45	K.21	K.20	K.45	K.21		
Single 8/20, 1.2/50 +5, -5	7.1	Unshielded Cable Inherent Longitudinal	500 V, R = 10 Ω	—	1.0 kV, R = 10 Ω	1.0 kV, R = 10 Ω	—	1.5 kV, R = 10 Ω	None	A
Multiple 8/20, 1.2/50 (Note 1) +5, -5	7.2	Shielded Cable Inherent Longitudinal	500 V, R = 0	—	1.0 kV, R = 0	1.0 kV, R = 0	—	1.5 kV, R = 0		

Test levels are given as the maximum DC charge voltage of the surge generator delivered to a tested equipment terminal and R is the value of current limit resistor. The current limit resistor, R, may be internal or external to the generator.

Note:

1. Cable screen is returned the port wires at the generator feed end see Figure 6.

Table 9. Lightning tests for ports connected to internal symmetric-pair cables.

2.11 ITU-T Recommendation K.45 (07-2003)

Resistibility of telecommunication equipment installed in the access and trunk networks to overvoltages and overcurrents

AC and lightning surge performance levels for the external line ports of access (OSP) equipment. Two surge withstand levels are specified, basic and enhanced. Primary equipment coordination tests are included.

2.12 ITU-T Recommendation K.50 (02/2000)

Safe limits of operating voltages and currents for telecommunication systems powered over the network

Provides guidance on voltages and currents that may be safely used to power telecommunication systems that are part of the network. Content is similar to UL 60950-21.

2.13 ITU-T Recommendation K.51 (02/2000)

Safety criteria for telecommunication equipment

Recommendation uses ITU-T recommendation K.50 and parts of IEC 60950.

2.14 IEC 61000-4-5 (2001-04), Ed. 1.1

Electromagnetic compatibility (EMC)- Part 4-5: Testing and measurement techniques - Surge immunity test

Lightning surge test circuits and levels for the external and internal line ports of networked equipment

2.15 ETSI EN 300 386-1, (2003-05)

Electromagnetic compatibility and Radio spectrum Matters (ERM); Telecommunication network equipment; ElectroMagnetic Compatibility (EMC) requirements

Lightning surge test circuits and performance level overview for the external and internal line ports of network equipment referencing IEC 61000-4-5.

2.16 ETSI EN 300 386-2, (1997-12)

Electromagnetic compatibility and Radio spectrum Matters (ERM); Telecommunication network equipment; ElectroMagnetic Compatibility (EMC) requirements; Part 2: Product family standard

Consolidated product test and performance standard for the external and internal line ports of network equipment. Internal port lightning surge testing references EN 61000-4-5 (1995) tests. External line power induction testing references ITU-T Recommendation K.20 (1993) and lightning surge references ITU-T Recommendation K.20 (1993) or K.21 (1988).

3 Surge Protective Devices

3.1 GR-1361, Issue 2, September 1998

Generic Requirements for Gas Tube Protector Units (GTPUS)

AC and lightning surge test circuits and performance levels for primary protectors using Gas Discharge Tubes, GDTs with and without current-limiting components.

3.2 GR-974-CORE, Issue 3

Generic Requirements for Telecommunications Line Protector Units (TLPUs)

AC and lightning surge test circuits and performance levels for primary protectors using GDTs or solid-state overvoltage protectors or hybrid combinations with and without current-limiting components.

3.3 UL 497, Edition 7 (April 2001)

Standard for Protectors for Paired Conductor Communications Circuits

AC and impulse surge test circuits and performance levels for voltage-limiting paired-conductor primary protectors with and without current-limiting components. These devices are to be used in accordance with the applicable requirements of the National Electrical Code, ANSI/NFPA 70.

3.4 UL 497A, Edition 3 (March 2001)

Standard for Secondary Protectors for Communications Circuits

AC and impulse surge test circuits and performance levels for current-limiting paired-conductor secondary protectors with and without voltage-limiting components. Test conditions are similar to those in UL 60950-1. These devices are to be used in accordance with the applicable requirements of the National Electrical Code, ANSI/NFPA 70.

3.5 UL 497B, Edition 4 (June 2004)

Standard for Protectors for Data Communication and Fire Alarm Circuits

AC and impulse surge test circuits and performance levels for voltage-limiting paired-conductor secondary protectors with and without current-limiting components.

3.6 UL 497C Edition 2 (August 2001)

Standard for Protectors for Coaxial Communications Circuits

AC and impulse surge test circuits and performance levels for voltage-limiting coaxial cable protectors with and without current-limiting components. These devices are to be used in accordance with the applicable requirements of the National Electrical Code, ANSI/NFPA 70.

3.7 IEEE Std C62.36-2000

IEEE Standard Test Methods for Surge Protectors Used in Low-Voltage Data, Communications, and Signalling Circuits.

Sets of AC and impulse surge tests for surge protectors with and without current-limiting components.

3.8 IEEE Std C62.64-1997

IEEE Standard Specifications for Surge Protectors Used in Low-Voltage Data, Communications, and Signalling Circuits

Sets of AC and impulse surge preferred performance levels for surge protectors with and without current-limiting components.

3.9 ITU-T Recommendation K.28 (03/1993)

Characteristics of semi-conductor arrester assemblies for the protection of telecommunications installations

AC and impulse surge tests and preferred performance levels for semi-conductor voltage-limiting paired-conductor primary protectors.

3.10 IEC 61643-21 (2000-09)

Low voltage surge protective devices - Part 21: Surge protective devices connected to telecommunications and signalling networks - Performance requirements and testing methods

Sets of AC and impulse surge tests for surge protectors with and without current-limiting components.

3.11 ATIS T1.337-2004

Requirements for Maximum Voltage, Current, and Power Levels in Network-Powered Transport Systems

This document provides maximum dc steady state and duration limited voltage, current, and power limits to be observed when powering transport systems over conventional network telecommunications twisted-pair conductors. The technical requirements contained herein are based on industry-recognized safety and design standards, addresses both the network and customer premises environments, and are independent of the transport system technology employed. Signalling levels and transients are not covered, but should be considered when evaluating a transport system for conformance

to these requirements if they will impact voltage, current, or power levels.

3.12 ATIS T1.338-2004

Electrical Coordination of Primary and Secondary Surge Protective Devices for Use in Telecommunications Circuits

This document covers the electrical coordination between primary and secondary surge protection devices that are both connected to ground. Proper coordination is essential to ensure that both primary and secondary protectors operate in a manner that provides the protected equipment with the most effective protection from AC power or lightning surges. This document does not address protection of the AC power service.

4 Surge Protective Components

4.1 REA Bulletin 345-83

Specification for Gas Tube Surge Arrestor, RUS PE- 80

AC and impulse surge tests and performance levels for heavy duty GDTs in rural service.

4.2 ITU-T Recommendation K.12 (02/2000)

Characteristics of gas discharge tubes for the protection of telecommunications installations

Sets of AC and impulse surge tests and preferred performance levels for GDTs

4.3 IEEE Std C62.3x

Series of Test Specifications For Surge Protective Components

4.3.1 IEEE Std C62.31-1987

IEEE Standard Test Specifications For Gas-Tube Surge-protective Devices

4.3.2 IEEE Std C62.32-1981

IEEE standard test specifications for low-voltage air gap surge-protective devices (excluding valve and expulsion type devices)

4.3.3 IEEE Std C62.33-1982

IEEE standard test specifications for varistor surge-protective devices

4.3.4 IEEE Std C62.35-1987

IEEE standard test specifications for avalanche junction semiconductor surge protective devices

4.3.5 IEEE Std C62.37-1996

IEEE standard test specification for thyristor diode surge protective devices

4.4 IEC 61643-3x1

Series of test specifications for low-voltage surge protective components

4.4.1 IEC 61643-311 (2001-10), Ed. 1.0

Components for low-voltage surge protective devices
- Part 311: Specification for gas discharge tubes (GDT)

4.4.2 IEC 61643-321 (2001-12) Ed. 1.0

Components for low-voltage surge protective devices
- Part 321: Specifications for avalanche breakdown diode (ABD)

4.4.3 IEC 61643-331 (2003-05) Ed. 1.0

Components for low-voltage surge protective devices
- Part 331: Specification for metal oxide varistors (MOV)

4.4.4 IEC 61643-341 (2001-11) Ed. 1.0

Components for low-voltage surge protective devices
- Part 341: Specification for thyristor surge suppressors (TSS)

© 2004 Bourns, Ltd. Certain parts of this document are in joint copyright with Canon Communications LLC and ATIS. Personal use of this material is permitted. However, permission to reprint/republish this material for advertising or promotional purposes or for creating new collective works for resale or redistribution to servers or lists, or to reuse any copyrighted component of this work in other works must be obtained from the relevant copyright holders.



Worldwide Sales Offices

Country	Phone	Fax
Benelux:	+31 (0)70 300 4333	+31 (0)70 300 4345
Brazil:	+55 11 5505 0601	+55 11 5505 4370
China:	+86 21 64821250	+86 21 64821249
France:	+33 (0)2 5473 5151	+33 (0)2 5473 5156
Germany:	+49 (0)69 800 78212	+49 (0)69 800 78299
India:	+91 484 302483	+91 484 302 287
Ireland:	+353 (0)1276 691087	+353 (0)1276 691088
Italy:	+390 2 389 00041	+390 2 389 00042
Japan:	+81 49 269 3204	+81 49 269 3297
Malaysia (KL Office):	+60 3 71183138	+60 3 71183139
Malaysia (Penang Office):	+60 4 6581771	+60 4 6582771
Singapore:	+65 63461933	+65 63461911
Switzerland:	+41 (0)41 768 5555	+41 (0)41 768 5510
Taiwan:	+886 2 25624117	+886 2 25624116
UK:	+44 (0)1276 691087	+44 (0)1276 691088
USA:	+1-951-781-5500	+1-951-781-5006
Non-Listed European Countries:	+41 (0)41 768 5555	+41 (0)41 768 5510

Technical Assistance

Region	Phone	Fax
Asia-Pacific:	+886 2 25624117	+886 2 25624116
Europe:	+41 (0)41 768 5555	+41 (0)41 768 5510
North America:	+1-951-781-5500	+1-951-781-5700

www.bourns.com

Bourns' products are available through an extensive network of manufacturer's representatives, agents and distributors. To obtain technical applications assistance, a quotation, or to place an order, contact a Bourns representative in your area.



Circuit Protection Solutions

"Telefuse" and "MINI TRIGARD" are trademarks of Bourns, Inc.
"TISP" is a trademark of Bourns, Ltd., and is Registered in U.S. Patent and Trademark Office.
"Multifuse" and "MSP" are registered trademarks of Bourns, Inc.
"Bourns" is a registered trademark of Bourns, Inc. in the U.S. and other countries.

COPYRIGHT© 2005, BOURNS, INC. LITHO IN U.S.A. SP 01/05 15M/K0427