

NOTES:

1. FINISH: Parts should have a smooth appearance, min.600 surface finish, with no gates and all flash removed.
2. Draft 1° on .095 dimension.
3. U.S. & Foreign Pat. Issued & Pend.

REVISIONS				
ECN #	REV	DESCRIPTION	DATE	INITIALS
	N/A	INITIAL RELEASE	3/21/07	SK
	001	REVISED PER ECR1110AZ01	1/29/10	KH
145	002	CHANGE IN MATERIAL	7/12/10	KH

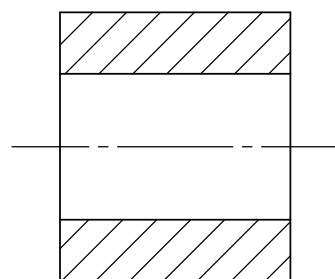
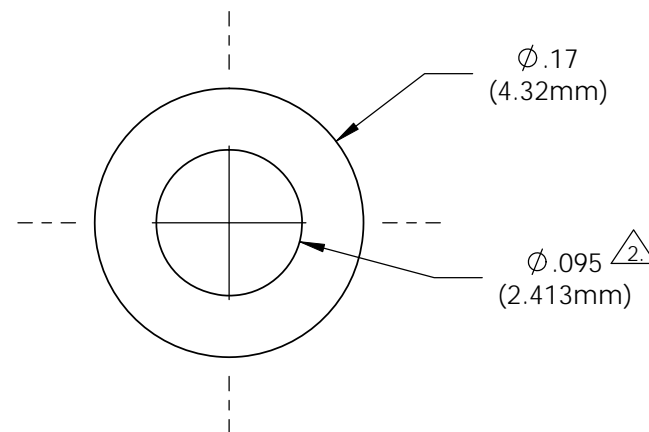
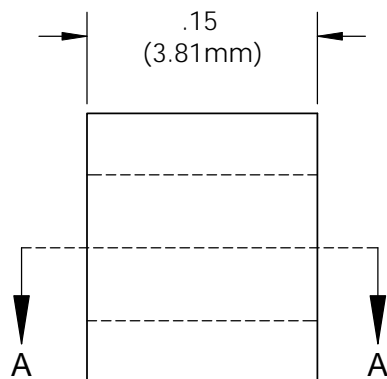

SECTION A-A

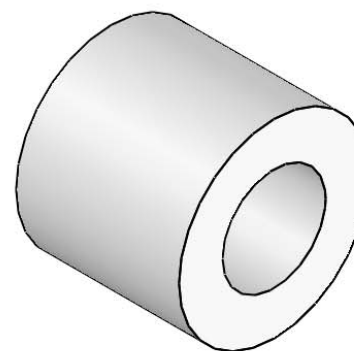

ISOMETRIC VIEW

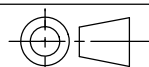
<small>UNLESS OTHERWISE SPECIFIED DIMENSIONS ARE IN INCHES:</small> ANGLES DECIMALS $\pm 1^\circ$.X $\pm .020$.XX $\pm .010$ FINISH .XXX $\pm .005$ <small>BREAK ALL CORNERS AND SHARP EDGES .050 MAX.</small>	MATERIAL TPE, BLACK		VISUAL COMMUNICATIONS COMPANY 190 Bosstick Boulevard, Suite 101 San Marcos, CA 92069 USA Phone (760) 560-1300 Fax (760) 560-1301 email vccsales@vcclite.com	
	FINISH SEE NOTES		TITLE: CLIPLITE RTN 100	
 THIRD ANGLE PROJECTION	APPROVALS	DATE	SIZE A	DWG. NO. RTN 100
	DRAWN K.HOWARD	1/29/10	CHECKED DPZ	2/22/10
DO NOT SCALE DRAWING			SCALE: 8:1	SHEET 1 OF 1

