

# PRODUCT DATA DRAWING

| REVISION HISTORY |             |       |          |
|------------------|-------------|-------|----------|
| REV              | DESCRIPTION | DATE  | APPROVED |
| -                | DCN 34595   | 10/06 | STW      |
| A                | DCN 36894   | 07/09 | JMC      |

**MATERIAL:**

**BODY & COUPLING NUT:** STAINLESS STEEL PER AMS-5640, ALLOY UNS S30300, TYPE 1

**CONTACTS & RETAINING CLIP:** BERYLLIUM COPPER PER ASTM B196, ALLOY UNS C17300, TD04

**SPRING:** STAINLESS STEEL PER ASTM A313, TYPE 331 ALLOY UNS S17700

**INSULATOR:** PTFE PER ASTM D1710, TYPE I, GRADE 1, CLASS B

**GASKET:** SILICONE RUBBER PER A-A-59588, CLASS 2B, GRADE 50/60

**FINISH:**

**BODY & CONTACTS:** GOLD PER ASTM B488, TYPE II, CODE C, CLASS 1.27; OVER NICKEL PER AMS-QQ-N-290, CLASS 1, .00005" MIN.

**COUPLING NUT:** PASSIVATED PER AMS-2700, TYPE 2

**PERFORMANCE:**

**IMPEDANCE:** 50 OHMS  
**FREQ. RANGE:** DC TO 18.0 GHz  
**DWV:** 1000 VRMS  
**OPERATING TEMP.:** -55°C TO +125°C  
**INSUL. RES.:** 5000 MEGOHMS, MIN.

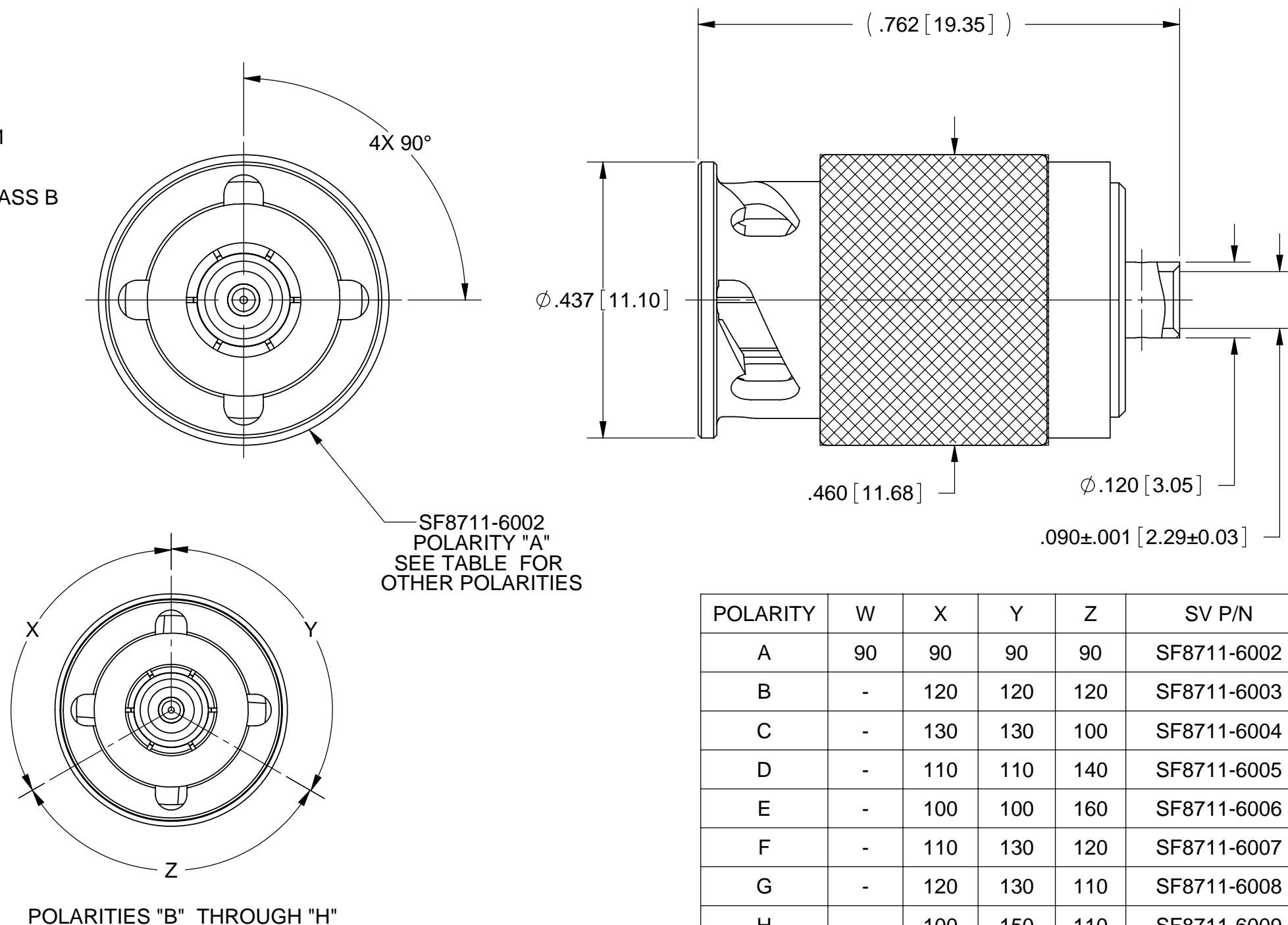

|  |           |
|--|-----------|
| MATERIAL:  | SEE NOTES |
| FINISH:  | SEE NOTES |
| SURFACE AREA:  | N/A       |
| <b>PROPRIETARY</b>   |           |
| THE INFORMATION CONTAINED IN THIS DRAWING IS THE SOLE PROPERTY OF SV MICROWAVE, INC. ANY REPRODUCTION IN PART OR AS A WHOLE WITHOUT THE WRITTEN PERMISSION OF SV MICROWAVE, INC IS PROHIBITED. |           |

|  |                                     |
|--|-------------------------------------|
| DIMENSIONS ARE IN INCHES TOLERANCES:                       |                                     |
| FRACTIONAL:  | ±1/64 ANGULAR: X° ±1'0" X'X' ±15'   |
| DECIMAL:   | .X ±.030<br>.XX ±.010<br>.XXX ±.005 |
| INTERPRET DIMENSIONS AND TOLERANCES PER ASME Y14.5M - 1994 |                                     |
| <b>THIRD ANGLE PROJECTION</b>                              |                                     |
|  |                                     |

|  |              |
|--|--------------|
| UNLESS OTHERWISE SPECIFIED   |              |
| 1) ALL DIMENSIONS ARE IN INCHES (MILLIMETERS)<br>2) ALL DIMENSIONS ARE AFTER PLATING.<br>3) BREAK CORNERS & EDGES .005 R. MAX.<br>4) CHAM. 1ST & LAST THREADS.<br>5) SURFACE ROUGHNESS 63-MIL-STD-10.<br>6) DIA: 'S ON COMMON CENTERS TO BE CONCENTRIC WITHIN .005 T.I.R.<br>7) REMOVE ALL BURRS |              |
| DRAWN:   | PDW 10/03/06 |
| CHECKED:   | STW 10/03/06 |
| APPROVED:  | STW 10/06/06 |

|  |                            |
|--|----------------------------|
| <b>SV Microwave, Inc.</b>  |                            |
| 2400 Centrepark West Drive, Suite 100<br>West Palm Beach, FL 33409 |                            |
| TITLE: <b>ZMA PLUG FOR TFLEX-405 CABLE</b>                         |                            |
| SIZE: <b>B</b>   | CAGE CODE: <b>95077</b>    |
| DWG. NO.:  | <b>SF8711-6002 TO 6009</b> |
| SCALE: 5:1   | SHEET 1 OF 1               |