

# Thin Film Pyroelectric Linear 128 Element Line Sensor Array

With Integrated Read-Out Electronics

## Introduction

The Pyreos line sensor array utilises our unique thin-film pyroelectric PZT material to offer class leading resolution and performance across a wide wavelength range at a very affordable price. The ASIC readout electronics output is a multiplexed, amplified and filtered analogue signal for each sensor element. The sensor is housed in a low profile hermetic metal package along with a temperature sensor, and is fitted with a linear variable filter or a broadband filter.

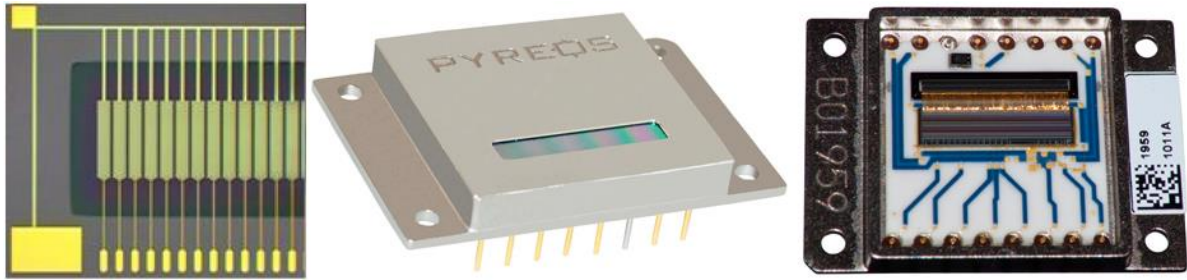

### Product Features

Wavelength range	0.1 to 100 $\mu\text{m}$ <sup>1</sup>
Operating temperature	Un-cooled operation
Number of pixels	128 sensor elements
Pixel sizes	60 $\mu\text{m}$ x 500 $\mu\text{m}$ ; 100 $\mu\text{m}$ pitch
Pixel operability	96% with no more than 2 bad in any 10
Dynamic range	>75 dB
Scan speed	10-1000 Hz

### Applications

General IR spectroscopy	Portable, robust spectral engines
Lubricating oil monitoring	Quality, wear, adulteration,
Foodstuffs	Constitution, adulteration
Process monitoring	Wind turbine, petrochemical, pharmaceutical
Temperature measurement	Non-contact line scanning measurement
Imaging	Line scanning

<sup>1</sup>Choice of filter windows available

### Filters Available

Part Number	PY0722	PY0738	PY1499
Filter Material	Silicon	LVF	LVF
Filter type	Broadband	Linear Variable filter	Linear Variable Filter
Transmission wavelength ( $\mu\text{m}$ )	-	5.5 to 11 (CWL 2%)	2.5 to 5 (CWL 2%)
Transmission wavenumbers ( $\text{cm}^{-1}$ )	-	1818 to 909	4000 to 2000

Please note: the information contained in this document is subject to change without further notification. Pyreos reserves the right to alter the performance and any resulting specification. Pyreos may choose not to supply any engineering sample devices as a commercial product. No responsibility is accepted for any consequential loss incurred. Pyreos Ltd, SMC, Alexander Crum Brown Road, Edinburgh EH9 3FF, UK. Tel: +441316507009, [www.pyreos.com](http://www.pyreos.com)

## Package Information

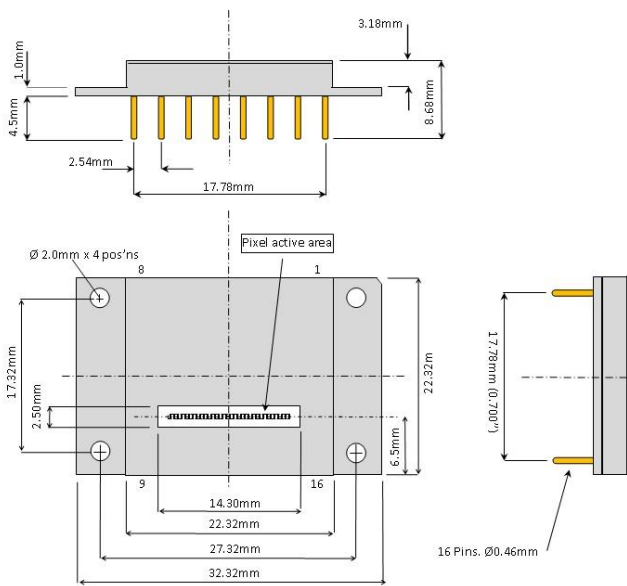

No.	Name	Comment
1.	CLK	Input clock CLK (trigger on rising edge)
2.	RES	Input clock RES (active low)
3.	VVR	Input clock VDR (active high)
4.	VDR	Input clock VDR (active high)
5.	VSH	Input clock VSH (active high)
6.	VD2	Operating voltage (+2.5 V)
7.	AVDD	Operating voltage (+5 V)
8.	VD2	Operating voltage (+2.5 V)
9.	OUT	Analogue signal output
10.	AGND	Ground
11.	n.c.	Not connected
12.	T+	Temperature sensor
13.	T-	Temperature sensor
14.	case	Case
15.	DGND	Ground
16.	DVDD	Operating voltage (+5 V)

Note: Pixel 1 is nearest pin 1 of the device.

## Circuit Diagram

The amplification circuit consists of low-noise preamplifiers for each individual sensor elements, analogue switches and an output amplifier. The pre-amplifiers transform the signal charges measured at each sensor element into a conditioned voltage. The amplified signal is then passed to sample and hold, multiplexer output buffer for the read-out process. The digital inputs are CMOS compatible. A 10k NTC thermistor is integrated within the package to monitor the line sensor temperature.

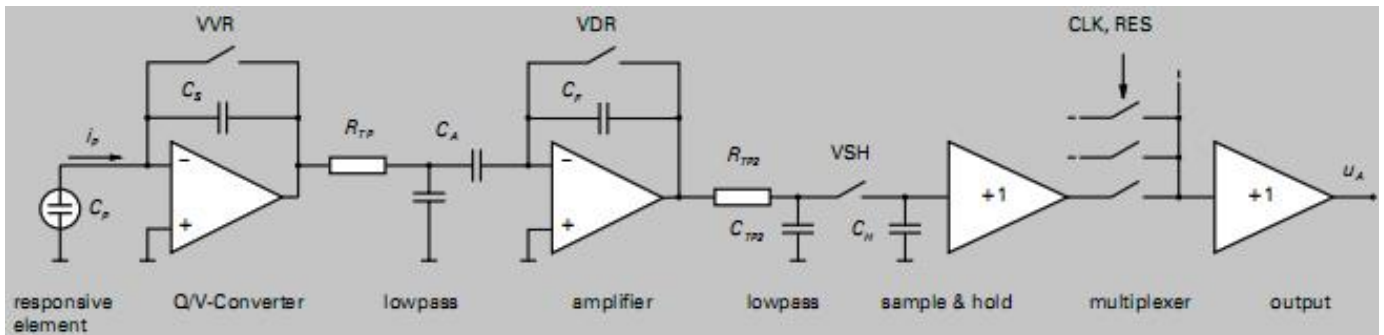

Thermistor is NTC, 1%. For more details check ERTJZEG103FA Datasheet on Industrial Panasonic website.

## Order Information

Please quote PYxxxx for your desired option of this product. Contact: [sales@pyreos.com](mailto:sales@pyreos.com)

## Clock Parameters

Similar to all pyroelectric sensors, the Pyreos thin-film pyroelectric line sensor array responds to and detects a change in infrared radiation intensity. It therefore requires a pulsed source of infrared radiation for measurement purposes.

Parameter <sup>1</sup>	Relative Value	Min. Values	Recommended Value
Chopping Frequency <sup>2</sup> $f_{ch}$		10 Hz	128 Hz
Read-out Clock CLK $f_{CLK} = 2 * f_{ch} * 268$	$1/t_{CLK}$	5.36 KHz	69 KHz
Reset clock low-impulse duration $t_{RES}$	$1/2 t_{CLK}$	1.8 $\mu s$	7.5 $\mu s$
Clock VVR high-impulse duration $t_{VVR}$	$2 t_{CLK}$	7.5 $\mu s$	30 $\mu s$
Clock VDR high-impulse duration $t_{VDR}$	$28 t_{CLK}$	200 $\mu s$	400 $\mu s$
Clock VSH high-impulse duration $t_{VSH}$	$1 t_{CLK}$	3.5 $\mu s$	15 $\mu s$

Maximum Settling Time at output  $t_{out}$  is 1  $\mu$  second

<sup>1</sup> All values for  $VDD = 5 V$ ,  $VD2 = 2.5V$

<sup>2</sup>  $t_{Ch low} = t_{Ch high}$

## Clock Diagram

