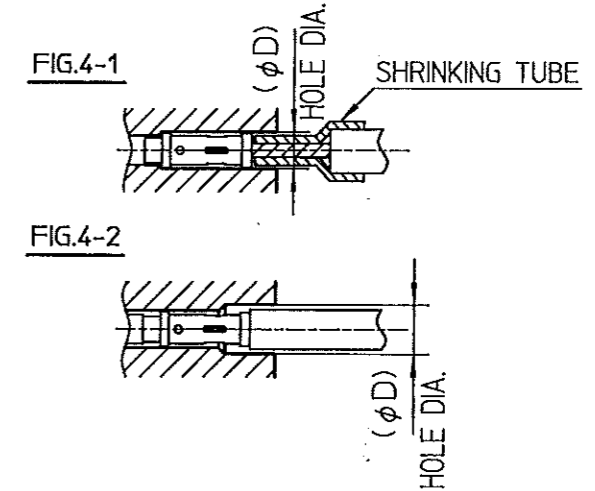

TABLE-1

CAT. NO.		ACCOMMODATION WIRE SIZE		FIG. NO.	INSULATION DIAMETER		WIRE STRIP LENGTH (±0.5)	INSTALLATION TOOLS			EXTRACTION TOOL
SOCKET	PIN	SOLID WIRE (NOTE 1)	STRANDED WIRE (mm ²)		MIN.	MAX.		M8ND DIE SET	M10S-1 DIE SET	STOP BUSHING	
RCS24M-9D28	RM24M-9D28	φ0.4~φ0.5	0.13~0.24	1	0.9 1.4	1.6 1.63	5.0	N24RT-10	S-9 S-10 (NOTE.3)	SL-40	RX20-25V2J OR RX20-25JG1
RCS20M-14D28	RM20M-14D28	φ0.65 ~φ0.8	0.3~0.61	1	—	2.6	5.0	N20RT-30J	S-10J	SL-40J	
RCS20M-12D28	RM20M-12D28			2	1.5	2.2		N20RT-30	S-10	SL-40	
RCS20M-13D28	RM20M-13D28			2	1.2	1.8					
RCS16M-23D28	RM16M-23D28	φ1.0~φ1.3	0.52~1.50	3	—	3.0 (NOTE.3)	7.0	N16RT-21	S-3D1	SL-39	
RCS14M-50D28	RM14M-50D28	—	2.0	4	—	—	SEE TABLE-2	—	S-3-14		

TABLE-2

CONNECTOR CAT. NO.	WIRE STRIP LENGTH	FIG. NO.	(φD)
MS__P/RM-__	(11.8) NOTE.3	4-1	3.2
UTG__	(12.4) NOTE.3	4-1	3.2
UTP__	(12.4) NOTE.3	4-1	3.2
G__20-30S__	(13.7) NOTE.3	4-1	3.2
G__22-38S__	(13.7) NOTE.3	4-1	3.2
G__24-48S__	(15.3) NOTE.3	4-1	3.2
G__ (THE OTHERS)	(11.8) NOTE.3	4-1	3.2
SMS__P/R-1	7.0±0.5	4-2	4.3
VGE1__	7.0±0.5	4-2	3.5
PIN CONTACT	(17.2) NOTE.3	4-1	
SOCKET CONTACT	(28.0) NOTE.3		



NOTES

- M8ND(2-INDENT TYPE TOOL) IS NOT RECOMMENDED FOR CRIMPING OF SOLID WIRE.
- DIE SET S-10 IS RECOMMENDED TO USE FOR THE WIRE OF INSULATION DIAMETER φ1.6.
- CONTROL THE WIRE STRIP LENGTH BY USAGE OF SHRINKING TUBE.
- IN CASE OF RCS/RM16M-23D28 ARE USED IN SMS_P/R-1, IT MAY BE ACCEPTABLE φ4.1 MAX.

FINISH
 CONTACT BODY : GOLD 0.75 μm MIN. OVER NICKEL(3.2 μm)
 RETAINING SPRING / INNER SPRING : NICKEL

SCALE				×	DESIGNED	NO.16 MACHINED CONTACT	
DIM. IN				mm	DRAWN	T.Osuga	CAT. NO.
MATERIAL					CHECKED	S.Ohnuki	RCS/RM__M-__D28
CONTACT BODY : BRASS					APPROVED	M.Ishi	DRAWING NO.
RETAINING SPRING / INNER SPRING : BERYLLIUM COPPER					DATE	Dec.22,'99	REV.
REFERENCE							JSC 95272
REV.	DATE	DESCRIPTION	CKD.				2

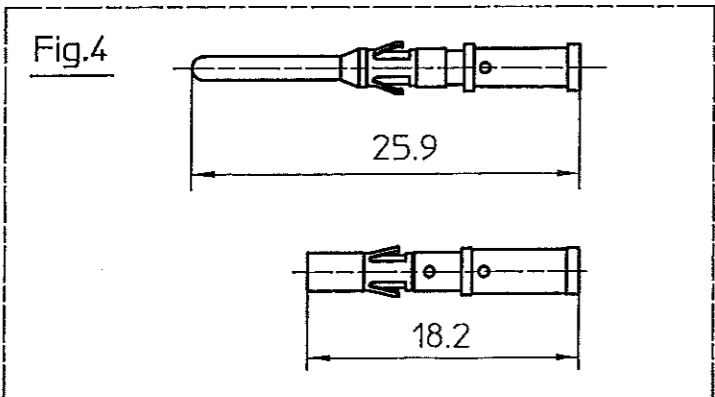
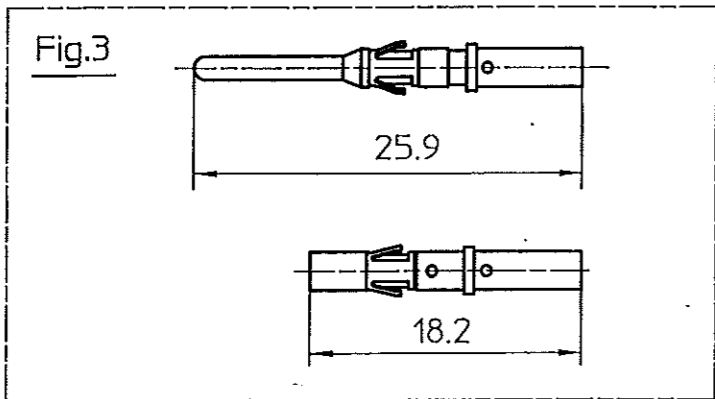
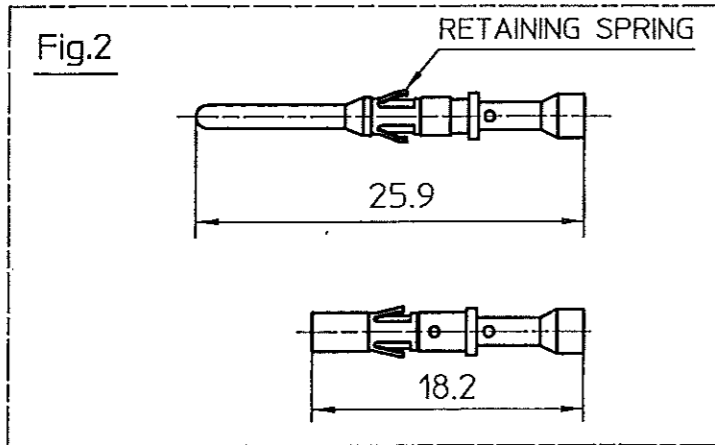
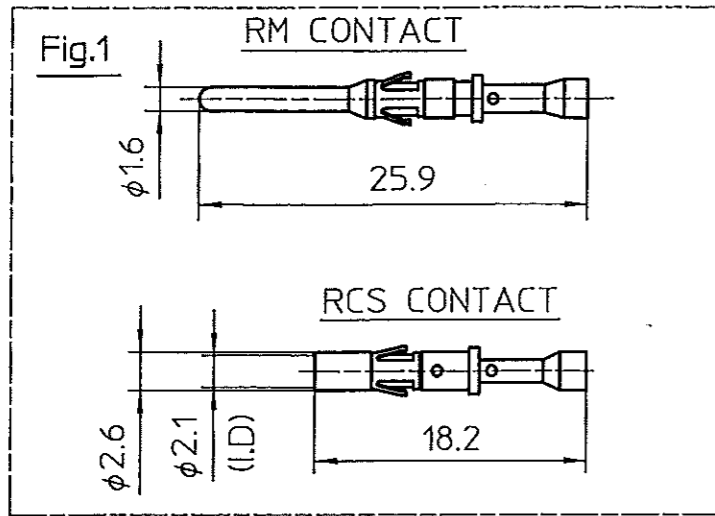
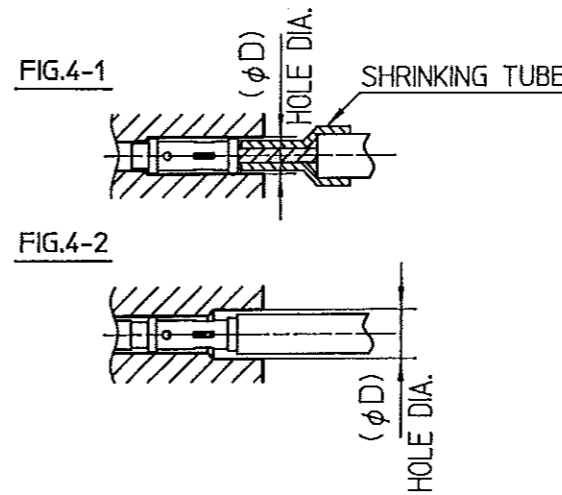

TABLE-1

CAT. NO.		ACCOMMODATION WIRE SIZE		FIG. NO.	INSULATION DIAMETER		WIRE STRIP LENGTH (±0.5)	INSTALLATION TOOLS			EXTRACTION TOOL
SOCKET	PIN	SOLID WIRE (NOTE 1)	STRANDED WIRE (mm ²)		MIN.	MAX.		M8ND DIE SET	M10S-1 DIE SET	STOP BUSHING	
RCS24M-9KJ	RM24M-9KJ	φ0.4~φ0.5	0.13~0.24	1	0.9 1.4	1.6 1.63	5.0	N24RT-10	S-9 S-10 (NOTE.2)	SL-40	RX20-25V2J OR RX20-25JG1 OR RX20-25GE2 (NOTE.5)
RCS20M-14KJ	RM20M-14KJ	φ0.65 ~φ0.8	0.3~0.61	1	—	2.6	5.0	N20RT-30J	S-10J	SL-40J	
RCS20M-12KJ	RM20M-12KJ			2	1.5	2.2		N20RT-30	S-10	SL-40	
RCS20M-13KJ	RM20M-13KJ			2	1.2	1.8		N20RT-30	S-10	SL-40	
RCS16M-23KJ	RM16M-23KJ	φ1.0~φ1.3	0.52~1.50	3	—	3.0 (NOTE.4)	7.0	N16RT-21	S-3D1	SL-39	
RCS14M-50KJ	RM14M-50KJ	—	2.0	4	—	—	SEE TABLE-2	—	S-3-14	—	

TABLE-2

CONNECTOR CAT. NO.	WIRE STRIP LENGTH	FIG. NO.	(φD)
MS___P/RM-___	(11.8) NOTE.3	4-1	3.2
UTG-___	(12.4) NOTE.3	4-1	3.2
UTP-___	(12.4) NOTE.3	4-1	3.2
G___20-30S-___	(13.7) NOTE.3	4-1	3.2
G___22-38S-___	(13.7) NOTE.3	4-1	3.2
G___24-48S-___	(15.3) NOTE.3	4-1	3.2
G___ (THE OTHERS)	(11.8) NOTE.3	4-1	3.2
SMS___P/R-1	7.0±0.5	4-2	4.3
VGE1-___	7.0±0.5	4-2	3.5
PIN CONTACT	(17.2) NOTE.3	4-1	
SOCKET CONTACT	(28.0) NOTE.3		



FINISH
 CONTACT BODY : GOLD 0.4μm MIN WITH INHIBITOR.
 OVER NICKEL(3.2μm)
 RETAINING SPRING / INNER SPRING : NICKEL

NOTES

- M8ND(2-INDENT TYPE TOOL) IS NOT RECOMMENDED FOR CRIMPING OF SOLID WIRE.
- DIE SET S-10 IS RECOMMENDED TO USE FOR THE WIRE OF INSULATION DIAMETER φ1.6.
- CONTROL THE WIRE STRIP LENGTH BY USAGE OF SHRINKING TUBE.
- IN CASE OF RCS/RM16M-23KJ ARE USED IN SMS_P/R-1, IT MAY BE ACCEPTABLE φ4.1 MAX.
- RX20-25GE2 IS RECOMMENDED TO USE FOR THE EXTRACT OF PIN CONTACT OF VGE1

SCALE	∞	DESIGNED	NO.16 MACHINED CONTACT	
DIM. IN	mm	DRAWN	CAT. NO. RCS/RM___M-___KJ	
MATERIAL	CONTACT BODY : BRASS RETAINING SPRING / INNER SPRING : BERYLLIUM COPPER	CHECKED	DRAWING NO. IJSC 00498	REV. 0
REV.	DATE	DESCRIPTION	APPROVED	DATE 2011/09/14
REFERENCE			SOURIAU JAPAN K.K. SOURIAU	