

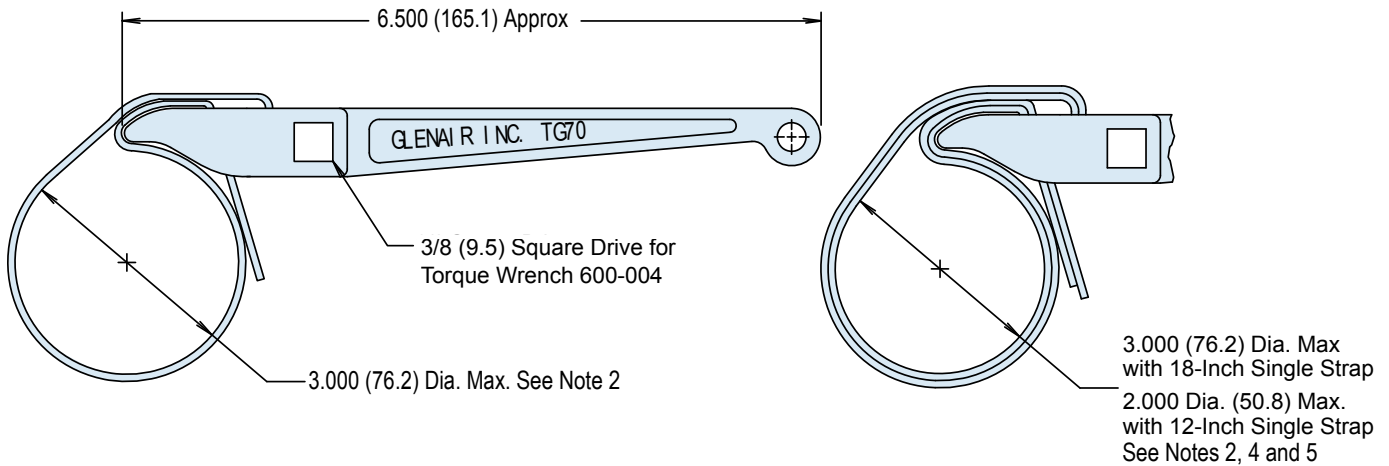

# TG70 Connector Strap Wrench With 3/8" Square Drive



**Basic Part Number**

**Torque Wrench (Omit for None)**

**TG70 - 1 - 18**

**Strap Length in Inches (See Notes 2 and 4)**  
Lengths Available: 12, 18, 24 and 36-Inch Only  
Standard length is 12 Inches,  
Omit Dash Number for Standard

- ### APPLICATION NOTES
1. These wrenches are made of the following materials:  
Wrench Handle - Aluminum Alloy/Nickel Plate.  
Wedge - Stainless Steel/Passivated.  
Strap - Impregnated Fabric. Straps are 1/2 inch (12.7) in width.
  2. Replacement straps are available. Specify part number G70515-xx for 12, 18, 24 or 36-inch strap. 24 and 36 inch for double wrap.
  3. Metric dimensions (mm) are indicated in parentheses.
  4. Double wrap as shown for heavy duty range.
  5. Not recommended for composite coupling nuts (use 600-091 or 600-157).

### VARIANCE CHART

#### TG-70 Strap Wrench Used with Glenair Torque Wrenches

Accessory Shell Size	Recommended Installation Torque			
	Light/Medium Duty ± 5 Inch Pounds		Heavy Duty ± 5 Inch Pounds	
	TG70 Torque	Part Torque	TG70 Torque	Part Torque
08/09	28	35	45	60
10/11	28	35	70	80
12/13	30	40	75	110 [80]
14/15	30	40	75	120 [80]
16/17	30	40	75	120 [80]
18/19	30	40	75	120 [80]
20/21	75	80	95	140 [100]
22/23	75	80	120*	140
24/25	75	80	120*	140
28			135*	150
32			150*	150
36			150*	150

\* TG70 Not Recommended For Values of 120 Inch Lbs. or Greater.

- ### VARIANCE CHART NOTES
1. Recommended installation torque is approximately 80% of MIL-C-85049 accessory thread strength values.
  2. Heavy duty installation torque values may be difficult to attain with the TG70 Strap Wrench; the values shown in brackets [ ] are the maximum attainable with the TG70 Strap Wrench using a single wrap.
  3. Glenair recommends using 600 series torque tools whenever possible. When torque loading exceeds 75 inch pounds, or to attain the heavy duty torque values shown, a double wrap strap provides suitable friction to achieve torque values.
  4. Glenair recommends that heavy duty torque values be directly read through the connector shell body with the use of 600-005 connectors holding tools.