

PART NAME: KNOB SCALE: 1:1 DATE: 3/5/09 DR. BY JAM

DAVIES MOLDING COMPANY
CAROL STREAM, ILLINOIS 60188

P/N 1505-B
BASE PART 1505-02
SET SCREW I1266

THIS DRAWING IS THE PROPERTY OF DAVIES MOLDING COMPANY, IS SUBMITTED SOLELY AS A DESIGN OR ENGINEERING PROJECT.
WE ACCEPT NO RESPONSIBILITY WHATSOEVER FOR THE PRACTICAL APPLICATION OF THE PIECES MADE TO THIS DESIGN.

(A)
(B)

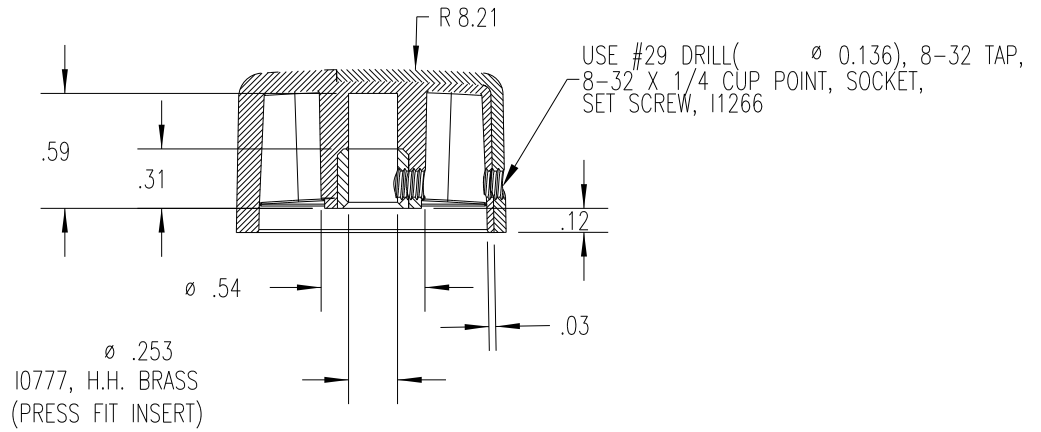
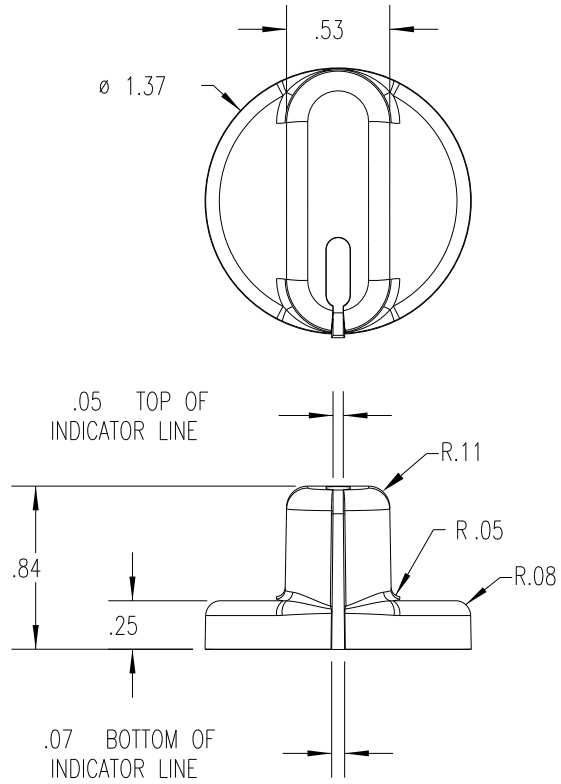

SECTION A-A

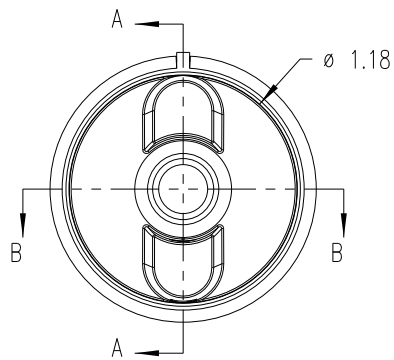

SECTION B-B

MATERIAL: SUBSTRATE: POLYPROPYLENE (CLD)
OVERMOLD: TPE (TPE3)

COLOR: SUBSTRATE: BLACK (PC-301)
OVERMOLD: BLACK (PC-301)

TOLERANCES: UNLESS OTHERWISE SPECIFIED	DO NOT SCALE DRAWING			
DECIMALS: X.XXX ± .005 X.XX ± .015	MM: X.XX ± 0.15MM X.X ± 0.4MM	B	ADDED BASE PART	JAM 3/10/14
FRACTIONS ± 1/64	ANG. ± 1°	A	MOLD # WAS 1505	JAM 12/14/09
		-	WAS SK1505-11	JAM 3/5/09
CHANGES				