

ITEM	PART #	QTY	DESCRIPTION	MATERIAL
1	SEE TABLE #1	1	WASHER	STAINLESS STEEL
2	SEE TABLE #1	1	SPRING	302 STAINLESS STEEL
3	AP-116-6	1	STUD	ANODIZED ALUMINUM ALLOY
4	SEE TABLE #1	1	BUSHING	RUBBER
5	AP-136-35	1	PLUG HSG MOLDING	GLASS FILLED NYLON & 303 SS
6	AP-136-30	1	CAP	ALUMINUM & BLACK CHROME
7	AP-136-31	1	ADAPTER - 90°	BRASS & BLACK CHROME
8	AP-136-33	1	STRAIN RELIEF	NYLON
9	AP-136-36	2	O-RING	ETHYLENE PROPYLENE
10	AP-136-41	1	O-RING	ETHYLENE PROPYLENE
11	AP-136-5	1	CLAMP SHELL (INNER)	BRASS WITH NICKEL PLATING
12	AP-136-6	1	CLAMP INNER (OUTER)	BRASS WITH NICKEL PLATING
13	AP-136-7	1	GASKET	RUBBER
14	AP-145-6	1	INSERT	DIALLYPHTHALATE, TYPE SDGF & GOLD PLATED BRASS

C AP-175RA-CP

TABLE #1				
AUDIO PLUG #	Ø CABLE	BUSHING	WASHER	SPRING
AP-175RA-01	Ø .165 ± .010	AP-116-17	AP-116-2	AP-116-4
AP-175RA-02	Ø .228 ± .010	AP-116-18	AP-116-2	AP-116-4
AP-175RA	Ø .250 ± .010	AP-116-8	AP-116-2	AP-116-4
AP-175RA-04	Ø .290 ± .010	AP-116-19	AP-116-2	AP-116-4
AP-175RA-05	Ø .320 ± .010	AP-116-20	AP-116-22	AP-116-21

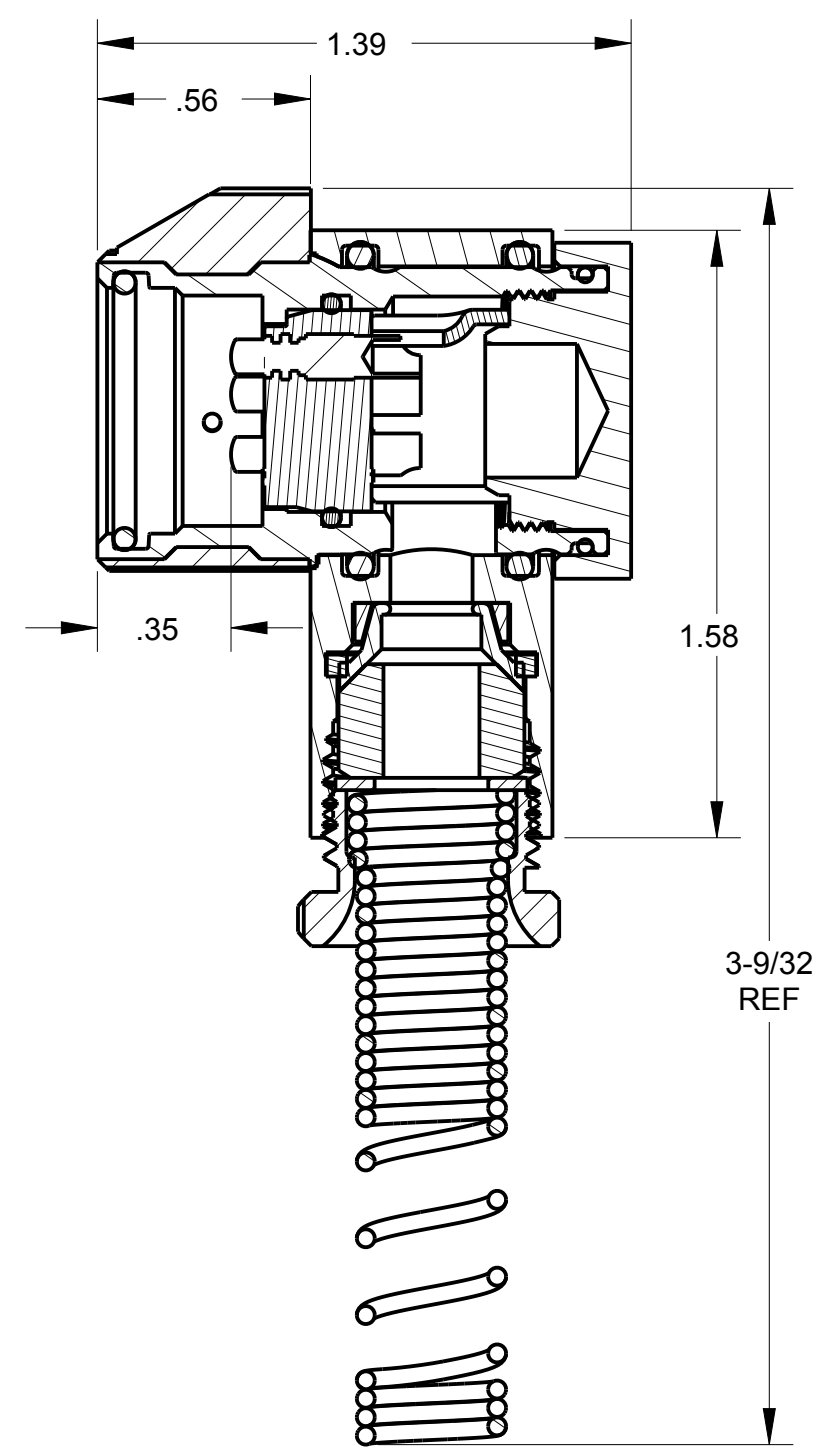
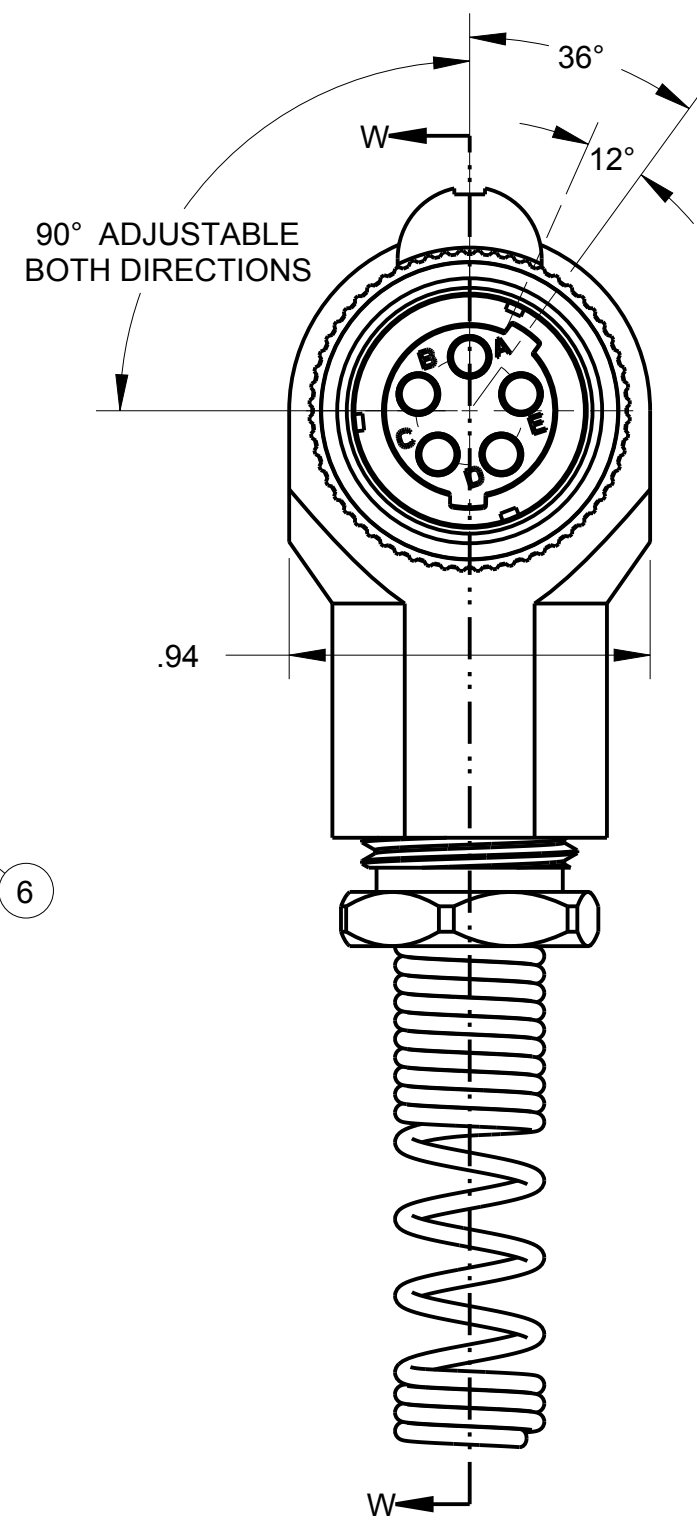
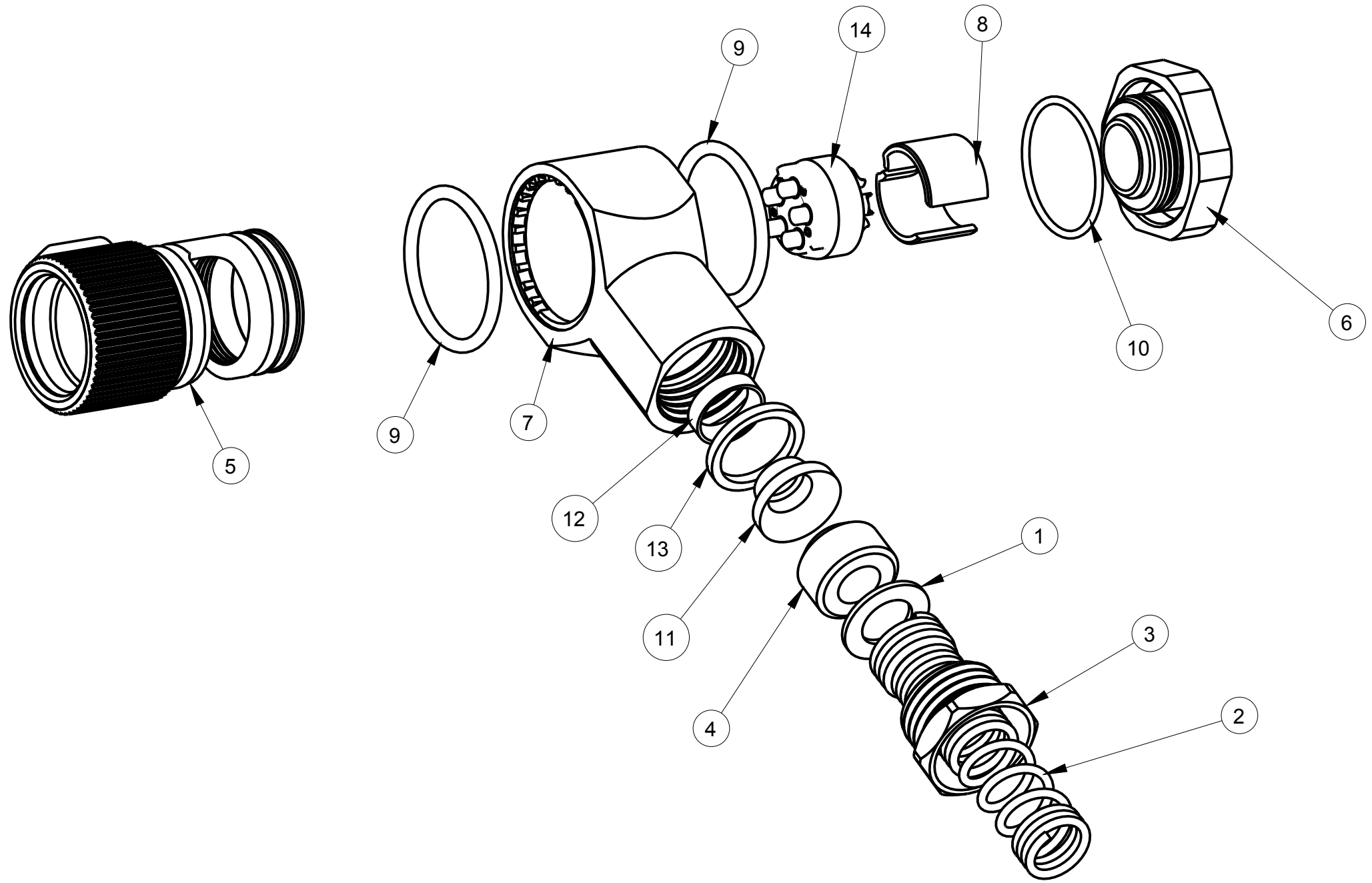

SECTION W-W

THIS DOCUMENT CONTAINS PROPRIETARY INFORMATION OF NEXUS, INCORPORATED AND SUCH INFORMATION MAY NOT BE DISCLOSED TO OTHERS FOR ANY PURPOSE OR USED FOR ANY PURPOSE WITHOUT THE WRITTEN CONSENT OF NEXUS.

				DWN.BY	HR	DATE	Jul-03-12	MATERIAL	
				CHECKED BY		DATE		FINISH	
				APPR.BY		DATE		WEIGHT	SCALE = 1.00 :1
				UNLESS OTHERWISE SPECIFIED DIMENSIONS ARE IN INCHES & OR (mm)				TITLE	
				TOLERANCES:				AUDIO PLUG - 90°	
				DECIMAL:				NEXUS	
				±.XX(X.X) ±.XXX(X.XX) ±.XXX(X.XXX)				STAMFORD, CONN	
				±.0X(0.X) ±.00X(0.0X) ±.000X(0.0XX)				SIZE DWG. NO.	
				FRACTION: ±X/XX ± X/XX				C AP-175RA-CP	
				ANGLES: ±X° ±X°				DO NOT SCALE DWG. SHEET 1 OF 1	

B	ADD: 12° ; 36° ; AP-175RA-01 TO AP-175RA-05	226	8/31 2015	HR
A	NEW RELEASE		7/3 2012	HR
LET.	REVISION	CN #	DATE	CHK