

# 857145

## 1960 MHz SAW Filter

### Applications

- For filtering in DPD path
- For ultra wideband applications
- Wireless infrastructure

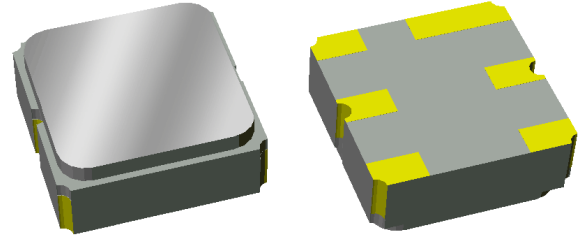

### Product Features

- Usable bandwidth 160 MHz
- Low Loss
- High attenuation,
- Excellent power handling
- Single-ended operation
- Matching required for operation at 50Ω
- Small Size: 3.00 x 3.00 x 1.22 mm
- Ceramic Surface Mount Package (SMP)
- Hermetically sealed
- RoHS compliant, Pb-free 

### Functional Block Diagram

Top view

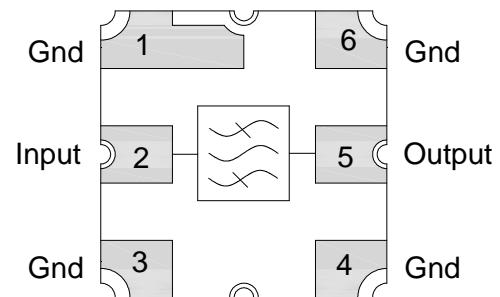

### General Description

857145 is a RF filter for wireless infrastructure applications. This filter was specifically designed for filtering in the digital pre-distortion path in Base Station applications. This filter is designed in a 3x3mm hermetic package and is part of our wide portfolio of RF filters in the same package.

Low insertion loss, coupled with high attenuation and excellent power handling, makes this filter a natural choice for our customers Downlink RF filtering needs.

### Pin Configuration

Pin #	SE	Description
2		Input
5		Output
1,3,4,6		Case Ground

### Ordering Information

Part No.	Description
857145	packaged part
857145-EVB	evaluation board

Standard T/R size = 5000 units/reel.

## Specifications

### Electrical Specifications <sup>(1)</sup>

Specified Temperature Range: <sup>(2)</sup> -40 to +85 °C

Parameter <sup>(3)</sup>	Conditions	Min	Typical <sup>(4)</sup>	Max	Units
Center Frequency		-	1960	-	MHz
Maximum Insertion Loss	1930 – 1990 MHz	-	3.0	4.0	dB
Amplitude Variation <sup>(5)</sup>	1930 – 1990 MHz	-	0.7	1.1	dB p-p
	1930 – 1990 MHz (Over any 5 MHz span)	-	0.3	0.6	dB p-p
	1880 – 2040 MHz	-	1.5	2.5	dB p-p
Phase Ripple <sup>(5)</sup>	1930 – 1990 MHz	-	2.6	6	deg p-p
	1930 – 1990 MHz (Over any 5 MHz span)	-	1.7	3	deg p-p
	1880 – 2040 MHz	-	21	36	deg p-p
Group Delay Variation <sup>(5)</sup>	1930 – 1990 MHz	-	2.8	6	ns p-p
	1880 – 2040 MHz	-	6.2	12	ns p-p
Absolute Delay	Average over 1930 – 1990 MHz	-	4	10	ns
EVM	1930 – 1990 MHz (Over any 3.84 MHz span)	-	0.8	1.5	%
IIP3 <sup>(6)</sup>	Tones 5 MHz separated, power > 5dBm per tone	44	52	-	dBm -
Temperature Drift <sup>(7)</sup>	1930 – 1990 MHz	-	0.22	0.3	dB
Input/Output VSWR	1930 – 1990 MHz	-	1.5	2.0:1	-
Relative Attenuation <sup>(8)</sup>	10 – 704 MHz	45	53	-	dB
	704 – 1561 MHz	25	29	-	dB
	1561 – 1622 MHz	25	29	-	dB
	1622 – 1790 MHz	25	29	-	dB
	2170 – 4000 MHz	25	28	-	dB
	4000 – 6000 MHz	20	25	-	dB
Source/Load Impedance <sup>(9)</sup>	Single-ended	-	50	-	Ω

Notes:

- All specifications are based on the TriQuint schematic shown on page 3.
- In production, devices will be tested at room temperature to a guardbanded specification to ensure electrical compliance over temperature.
- Electrical margin has been built into the design to account for the variations due to temperature drift and manufacturing tolerances.
- Typical values are based on average measurements at room temperature.
- Variation is defined as the total peak to peak variation over the defined frequency range.
- To be measured only during engineering development.
- Temperature Drift specification is defined on Page 3 and is guaranteed by design and won't be measured in production
- Relative to maximum insertion loss at center frequency.
- This is the optimum impedance in order to achieve the performance shown.

### Absolute Maximum Ratings

Parameter	Rating
Operable Temperature	-40 to +85 °C
Storage Temperature	-40 to +85 °C
Input Power	+22 dBm (max) CW for 24 hours at +55 °C

Operation of this device outside the parameter ranges given above may cause permanent damage.

### Temperature Drift Specification

Temperature Drift Equations:

$$\text{Temp Drift}_{\text{high}} = \left| \frac{\max(T_{\text{ambient}} - T_{\text{hot}}) - \min(T_{\text{ambient}} - T_{\text{hot}})}{2} \right|$$

$$\text{Temp Drift}_{\text{low}} = \left| \frac{\max(T_{\text{ambient}} - T_{\text{cold}}) - \min(T_{\text{ambient}} - T_{\text{cold}})}{2} \right|$$

Temperature Drift Terms Defined:

$T_{\text{ambient}}$  - Transmission power in dB measured at +25 degrees C.

$T_{\text{hot}}$  - Transmission power in dB measured at +85 degrees C.

$T_{\text{cold}}$  - Transmission power in dB measured at -40 degrees C.

Temperature Drift - Greater of  $\text{Temp Drift}_{\text{high}}$  vs  $\text{Temp Drift}_{\text{low}}$

### Reference Design

#### Schematic

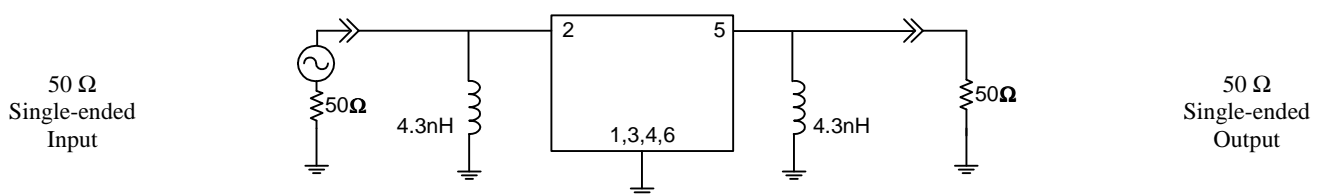

#### PC Board

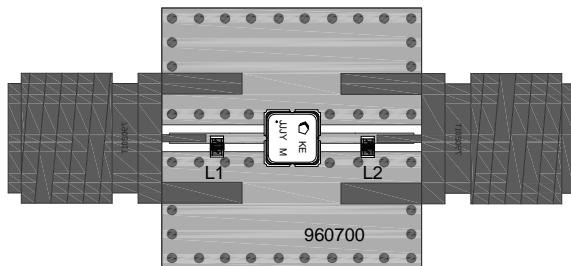

Notes:

- Top, middle & bottom layers: 1 oz copper
- Substrates: FR4 dielectric, .031" thick
- Finish plating: Nickel: 3-8μm thick, Gold: .03-.2μm thick
- Hole plating: Copper min .0008μm thick

#### Mounting Configuration

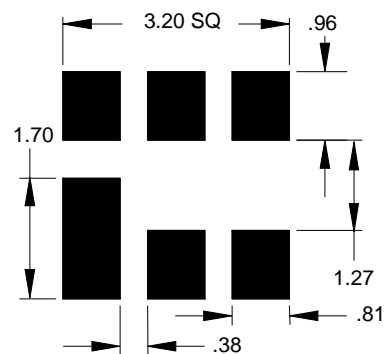

Notes:

1. All dimensions are in millimeters.
2. This footprint represents a recommendation only.

### Bill of Material

Reference Desg.	Value	Description	Manufacturer	Part Number
L1	4.3nH	Coil Wire-wound, 0402, 5%	MuRata	LQW15AN4N3D00
L2	4.3nH	Coil Wire-wound, 0402, 5%	MuRata	LQW15AN4N3D00
SMA	N/A	SMA connector	Radiall USA Inc.	9602-1111-018
PCB	N/A	3-layer	multiple	960700

### Typical Performance (at room temperature)

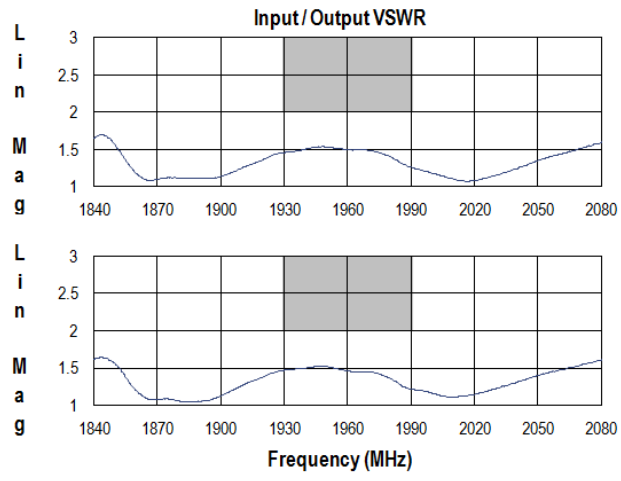
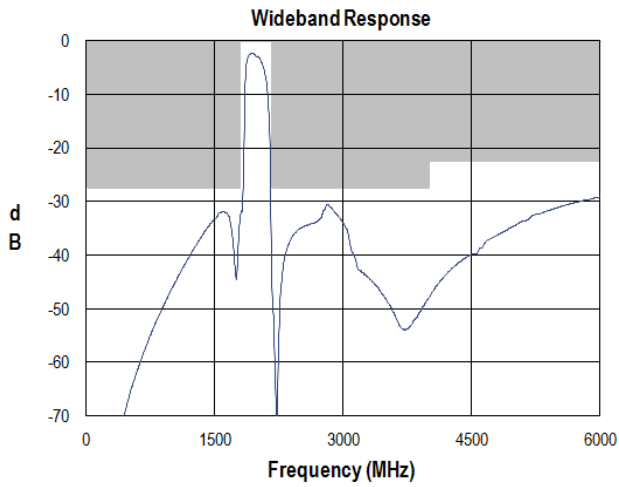
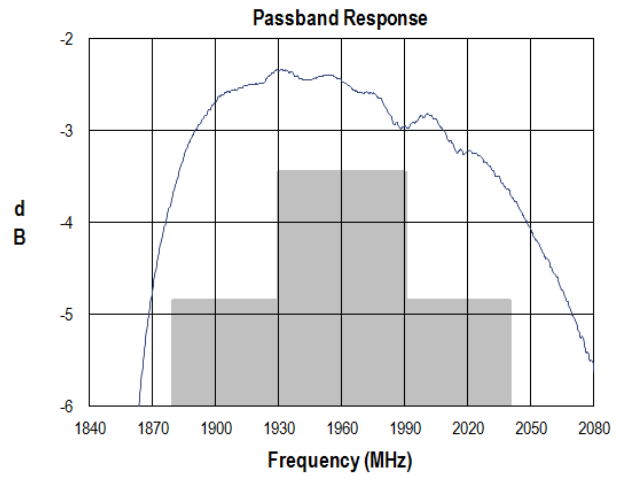
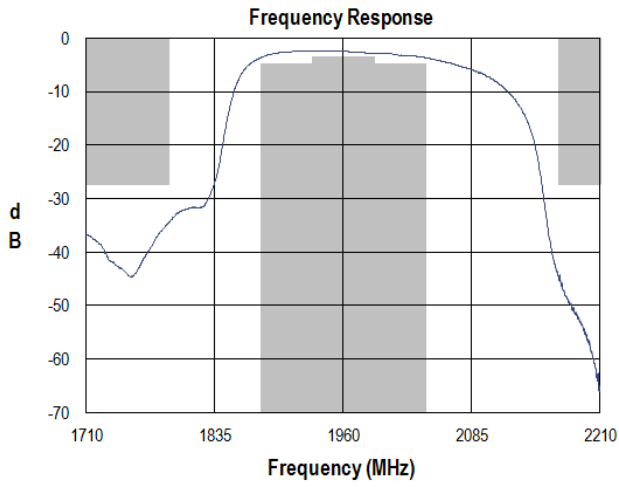

Input Smith Chart

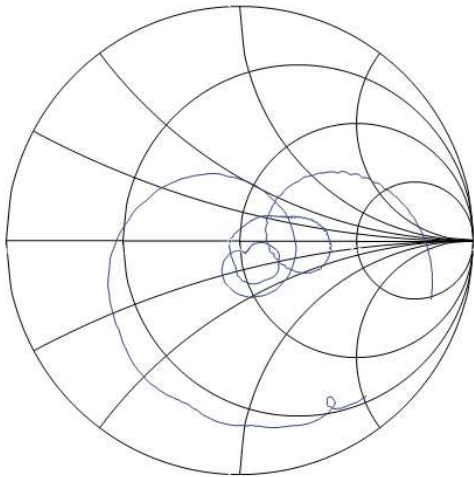

Output Smith Chart

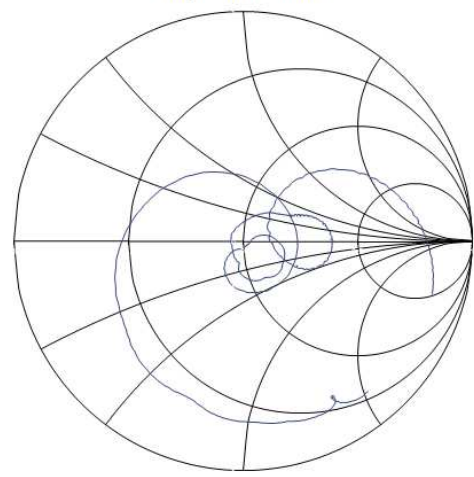

**Mechanical Information**

**Package Information, Dimensions and Marking**

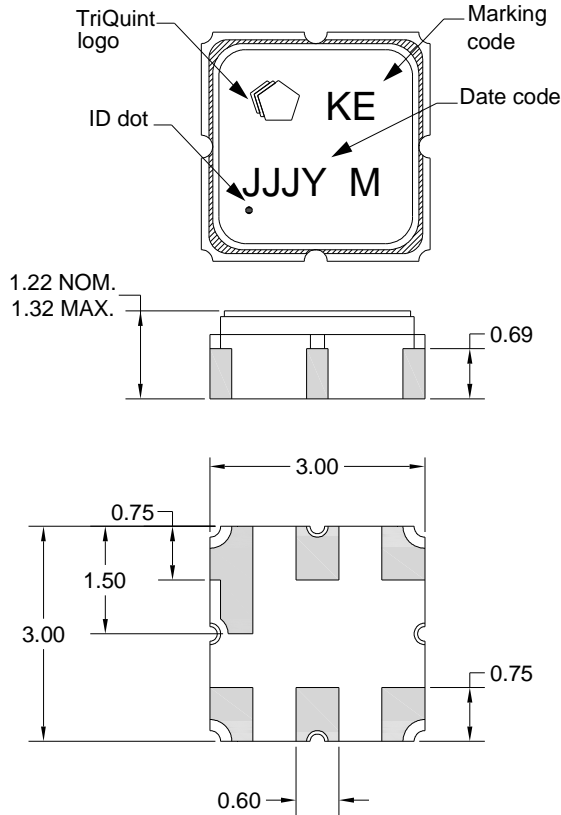

Package Style: SMP-12A  
 Dimensions: 3.00 x 3.00 x 1.22 mm

Body:  $Al_2O_3$  ceramic  
 Lid: Kovar, Ni plated  
 Terminations: Au plating 0.5 - 1.0 $\mu$ m, over a 2-6 $\mu$ m Ni plating

All dimensions shown are nominal in millimeters  
 All tolerances are  $\pm 0.15$ mm except overall length and width  $\pm 0.10$ mm

The date code consists of day of the current year (Julian, 3 digits), Y = last digit of the year, and M = manufacturing site code

**Tape and Reel Information**

Standard T/R size = 5000 units/reel. All dimensions are in millimeters

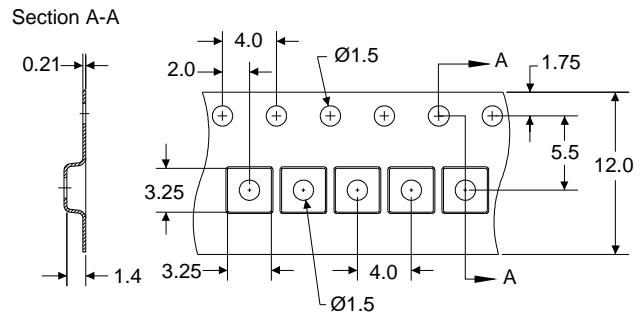
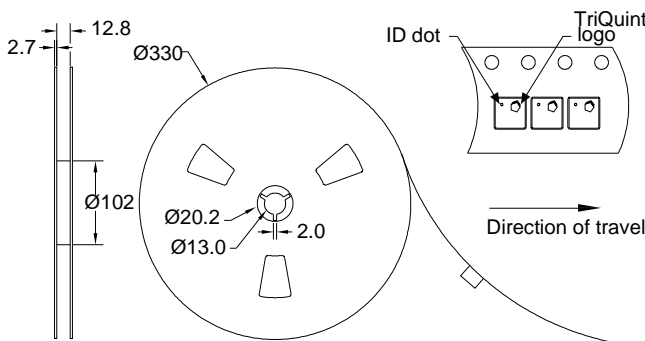

## Product Compliance Information

### ESD Information



#### Caution! ESD-Sensitive Device

ESD Rating: 1B

Value: Passes  $\geq 550$  V min.  
Test: Human Body Model (HBM)  
Standard: JEDEC Standard JESD22-A114

ESD Rating: B

Value: Passes  $\geq 200$  V min.  
Test: Machine Model (MM)  
Standard: JEDEC Standard JESD22-A115

### MSL Rating

Devices are Hermetic, therefore MSL is not applicable

### Solderability

Compatible with the latest version of J-STD-020, lead free solder, 260°C

Refer to [Soldering Profile](#) for recommended guidelines.

This part is compliant with EU 2002/95/EC RoHS directive (Restrictions on the Use of Certain Hazardous Substances in Electrical and Electronic Equipment).

This product also has the following attributes:

- Halogen Free (Chlorine, Bromine)
- Antimony Free
- TBBP-A (C<sub>15</sub>H<sub>12</sub>Br<sub>4</sub>O<sub>2</sub>) Free
- PFOS Free
- SVHC Free

## Contact Information

For the latest specifications, additional product information, worldwide sales and distribution locations, and information about TriQuint:

Web: [www.triquint.com](http://www.triquint.com)  
Email: [info-sales@tqs.com](mailto:info-sales@tqs.com)

Tel: +1.407.886.8860  
Fax: +1.407.886.7061

For technical questions and application information:

Email: [flapplication.engineering@tqs.com](mailto:flapplication.engineering@tqs.com)

## Important Notice

The information contained herein is believed to be reliable. TriQuint makes no warranties regarding the information contained herein. TriQuint assumes no responsibility or liability whatsoever for any of the information contained herein. TriQuint assumes no responsibility or liability whatsoever for the use of the information contained herein. The information contained herein is provided "AS IS, WHERE IS" and with all faults, and the entire risk associated with such information is entirely with the user. All information contained herein is subject to change without notice. Customers should obtain and verify the latest relevant information before placing orders for TriQuint products. The information contained herein or any use of such information does not grant, explicitly or implicitly, to any party any patent rights, licenses, or any other intellectual property rights, whether with regard to such information itself or anything described by such information.

TriQuint products are not warranted or authorized for use as critical components in medical, life-saving, or life-sustaining applications, or other applications where a failure would reasonably be expected to cause severe personal injury or death.