

# Customer Information Sheet

DRAWING No.: DOXXX-42

SHEET 2 OF 2

IF IN DOUBT - ASK

©

NOT TO SCALE

THIRD ANGLE PROJECTION

ALL DIMENSIONS IN mm

PART No.	No. OF WAYS	STYLE (SEE NOTE 2)	DIM 'A'	DIM 'B'	DIM 'C'	DIM 'D'
D0806-42	6	1	7.60	10.02	7.62	5.08
D0808-42	8	1	10.10	10.02	7.62	7.62
D0814-42	14	1	17.70	10.02	7.62	15.24
D0816-42	16	1	20.30	10.02	7.62	17.78
D0818-42	18	2	22.80	10.02	7.62	20.32
D0820-42	20	2	25.30	10.02	7.62	22.86
D0822-42	22	2	27.80	12.60	10.16	25.40
D0922-42	22	2	27.80	10.02	7.62	25.40
D0724-42	24	2	30.40	12.60	10.16	27.94
D0824-42	24	2	30.40	17.64	15.24	27.94
D0924-42	24	2	30.40	10.02	7.62	27.94
D0828-42	28	2	35.50	17.64	15.24	33.02
D0832-42	32	2	40.60	17.64	15.24	38.10
D0836-42	36	3	45.70	17.64	15.24	43.18
D0840-42	40	3	50.80	17.64	15.24	48.26
D0948-42	48	3	60.90	17.64	15.24	58.42
D0864-42	64	4	25.40	25.40	22.86	78.74

**SPECIFICATION:**

**MATERIAL:**  
 MOULDING = GLASS FILLED PCT, BLACK, UL94V-0  
 CONTACT SHELL = BRASS  
 CONTACT CLIP = BERYLLIUM COPPER

**FINISH:**  
 CONTACT SHELL = 5µ 100% TIN OVER NICKEL  
 CONTACT CLIP = 0.25µ GOLD OVER NICKEL

**ELECTRICAL:**  
 CURRENT RATING = 1 AMP  
 VOLTAGE RATING = 100V AC / 150V DC  
 CONTACT RESISTANCE = 10 MILLIOHMS MAX  
 INSULATION RESISTANCE = 10,000 MEGOHMS MIN  
 DIELECTRIC STRENGTH = 1,000V AC MIN

**MECHANICAL:**  
 DURABILITY = 100 CYCLES  
 INSERTION FORCE (∅0.46mm GAUGE) = 5N MAX  
 WITHDRAWAL FORCE (∅0.46mm GAUGE) = 0.5N MIN

**ENVIRONMENTAL:**  
 TEMPERATURE RANGE = -55°C TO +125°C  
 FOR COMPLETE SPECIFICATION, SEE COMPONENT SPECIFICATION C004XX (LATEST ISSUE)

STYLE '1'

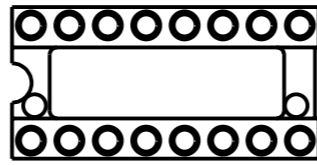

STYLE '2'

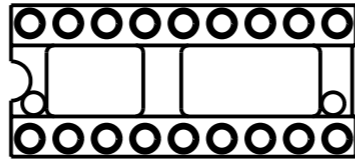

STYLE '3'

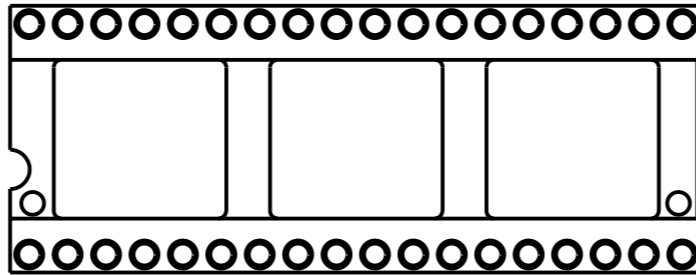

STYLE '4'

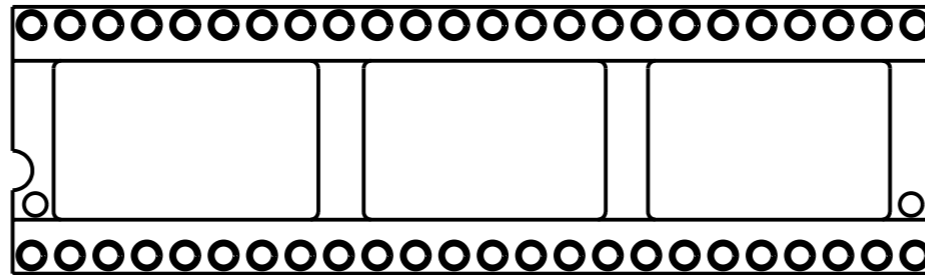

STYLE DIAGRAMS  
(SEE NOTE 2)

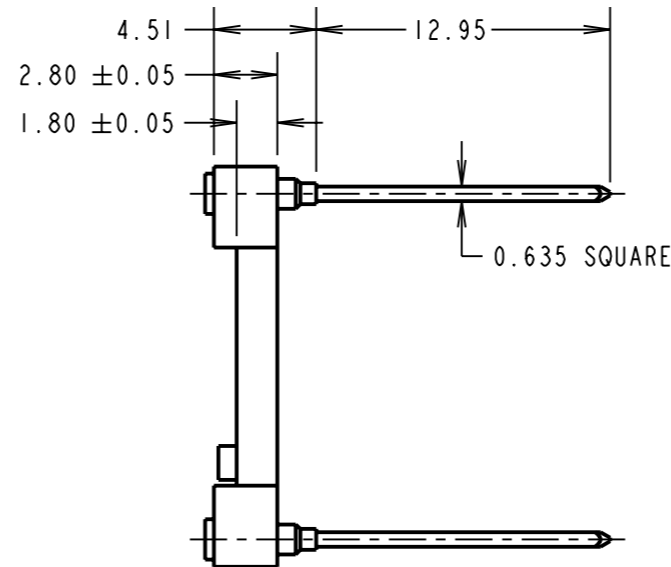
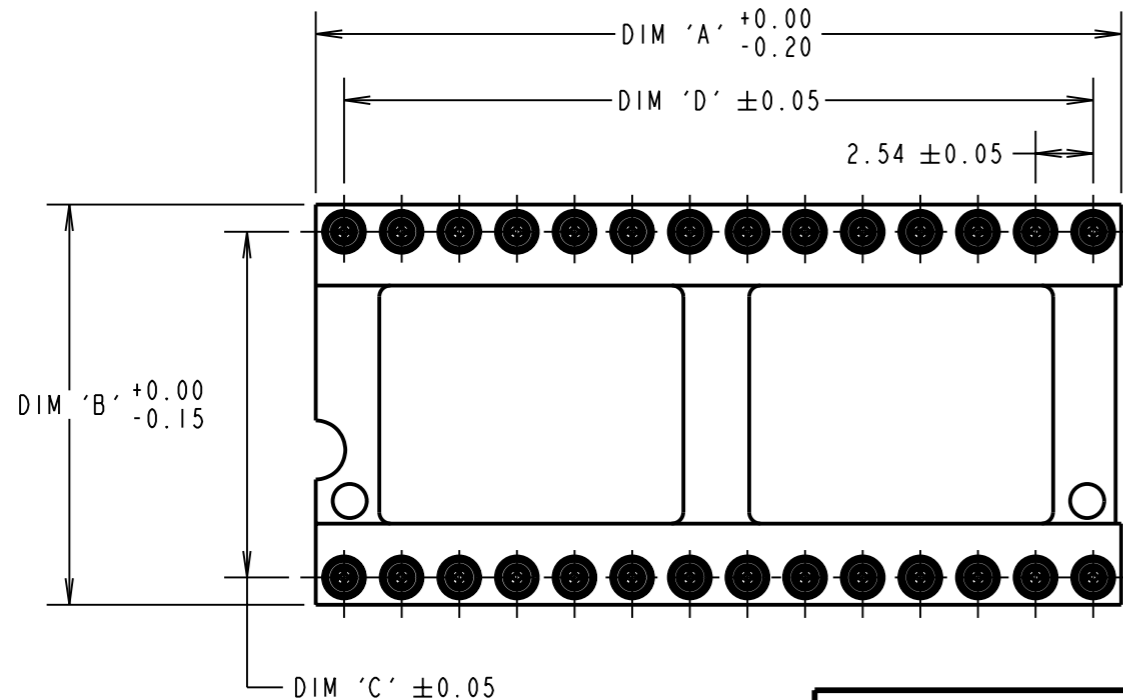

- NOTES:  
 1. RECOMMENDED HOLE SIZE = ∅1.00mm  
 2. STYLE REFERS TO NUMBER OF CENTRE BARS ONLY

ORDER CODE:  
**DOXXX-42**

PITCH ————  
 SEE TABLE

No. OF WAYS ————  
 SEE TABLE

FINISH ————  
 GOLD CLIP, 100% TIN SHELL

CP	10	14.01.10	10640
NAME	ISS.	DATE	C/NOTE
APPROVED: C.PENROSE			
CHECKED: R.ADDE			
DRAWN: W.J.BOURNE			
CUSTOMER REF.:			
ASSEMBLY DRG:			

**HARWIN**

HARWIN USA TEL: 603 893 5376 FAX: 603 893 5396 mis@harwin.com	HARWIN Europe (UK) TEL: 023 9231 4545 FAX: 023 9231 4590 mis@harwin.co.uk	HARWIN Asia TEL: +65 6 779 4909 FAX: +65 6 779 3868 mis@harwin.com.sg
--	--	--

THIS DRAWING AND ANY INFORMATION OR DESCRIPTIVE MATTER SET OUT HEREON ARE CONFIDENTIAL AND COPYRIGHT PROPERTY OF THE HARWIN GROUP AND MUST NOT BE DISCLOSED, LOANED, COPIED OR USED FOR MANUFACTURING, TENDERING OR FOR ANY OTHER PURPOSE WITHOUT THEIR WRITTEN PERMISSION.

**TOLERANCES**  
 X. = ±1mm  
 X.X = ±0.25mm  
 X.XX = ±0.10mm  
 X.XXX = ±0.01mm  
 ANGLES = ±5°  
 UNLESS STATED

**MATERIAL:**  
 SEE ABOVE

**FINISH:** SEE ABOVE

**S/AREA:** mm<sup>2</sup>

**TITLE:**  
 IC SOCKET WIRE WRAP ASSEMBLY (3-LEVEL)

**DRAWING NUMBER:**  
**DOXXX-42**

SHT 2 OF 2