

REV.	DESCRIPTION	DATE	APPROVED
A	Engineering Release.	12/13/06	M. C.

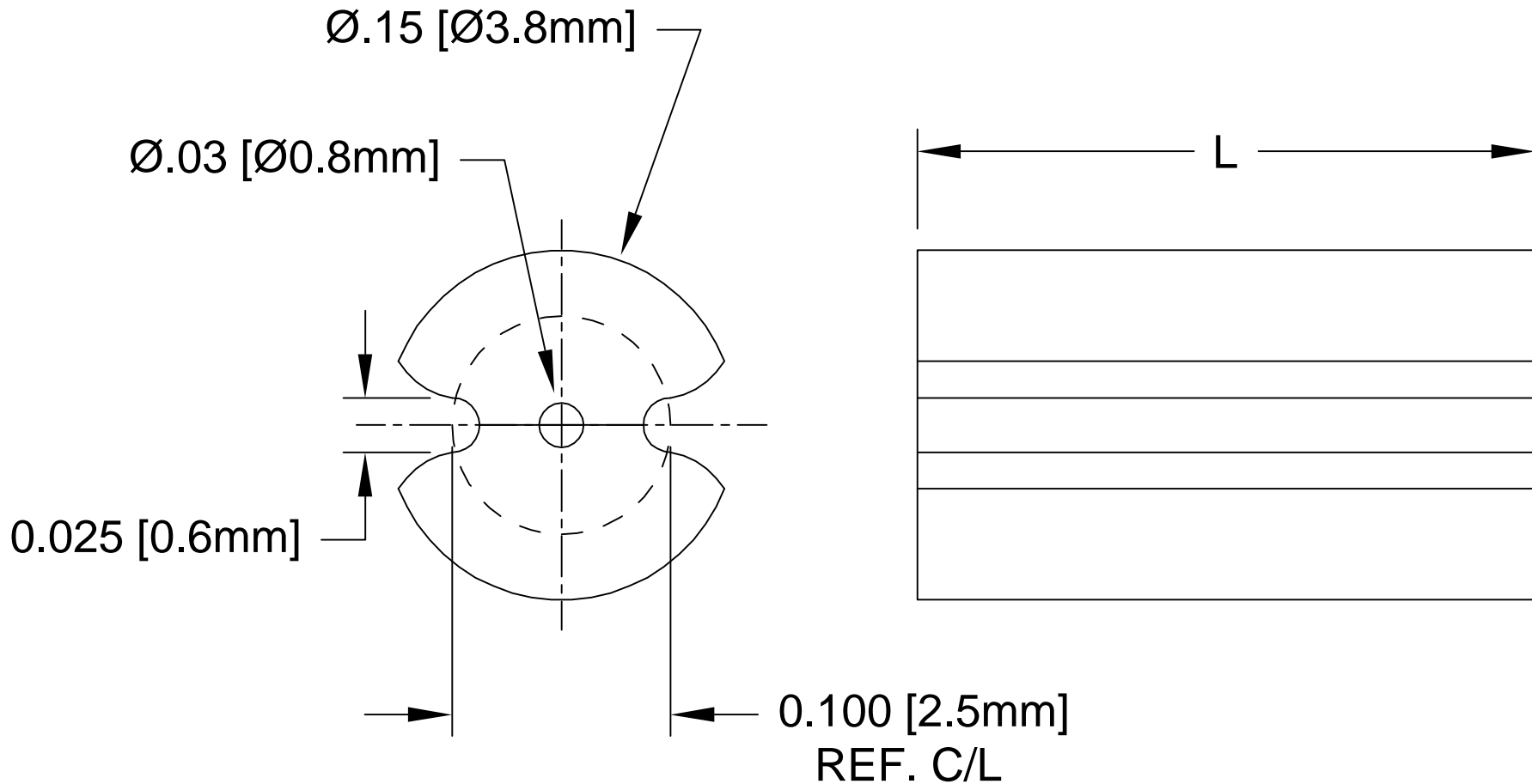



3. TOLERANCE "L" DIMENSION:

- 0.030 - 0.500 (1.0 - 12.7mm)±0.005(0.1mm)
- 0.505 - 0.750 (12.8 - 19.1mm)±0.008(0.2mm)
- 0.755 - 1.250 (19.2 - 31.8mm)±0.015(0.4mm)

2. MATERIAL: DUPONT ZYTEL FN714 NC010 NYLON 66, 94V-0, PANTONE BLUE 294C.

1. GENERAL SPECIFICATIONS: BIVAR EXTRUDED PRODUCT SPECIFICATION BV00-E105.

STANDARD TOLERANCE ( UNLESS OTHERWISE SPECIFIED )		 4 THOMAS, IRVINE, CA. 92618 TEL: (949) 951-8808 FAX: (949) 951-3974	
DECIMALS	ANGULAR		
.X ±.1	X° ±1°	 TITLE: HI-TEMP EXTRUDED SELF-RETAINING LED MOUNT	
.XX ±.01			
.XXX ±.005			
DESIGNED: <b>Ty Yin</b>	DATE: <b>12/13/06</b>	PART NO: <b>ENM 1-XXXX</b>	REVISION: <b>A</b>
CHECKED: <b>M. Chen</b>	DATE: <b>12/13/06</b>	CAGE CODE : <b>32559</b>	SHEET # <b>1 OF 1</b>
CAD GENERATED DOCUMENT, DO NOT MEASURE DRAWING.			