

*New*

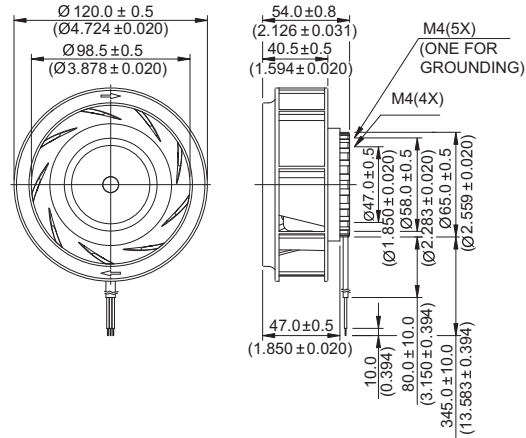

# KHB Ø 120 x 54 MM SERIES

## DIMENSIONS DRAWING



UNIT :  $\frac{\text{mm}}{\text{INCH}}$

- \* Bearing Type  
Ball Bearings
- \* Material  
Impeller : Plastic (UL 94V-0)  
Pillow : Die-Cast Aluminum
- \* Lead Wires :  
UL 1007 AWG #24 Or Equivalent  
Red Wire Positive (+)  
Black Wire Negative (-)
- \* Weight : 330g (11.64 oz)

## P & Q CURVE (AT RATED VOLTAGE)



## MOUNTING PANEL CUTOUT

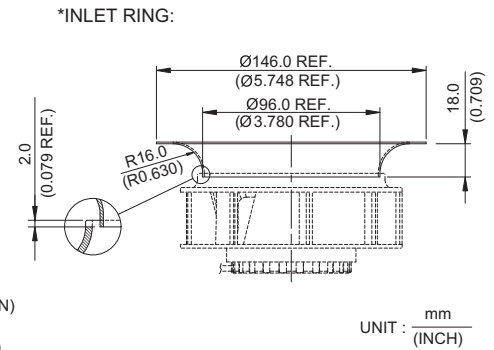

UNIT :  $\frac{\text{mm}}{\text{INCH}}$

MODEL		Rated Voltage	Operating Voltage Range	Rated Current	Rated Input Power	Speed	Maximum Air Flow		Maximum Air Pressure		Noise
PART NO.	FUNCTION	VDC	VDC	Amp	Watt	R.P.M.	m <sup>3</sup> / min	CFM	mmH <sub>2</sub> O	IN H <sub>2</sub> O	dB-A
KHB1248VHS	-R00 / -F00	48	32.0 to 80.0	0.27	12.96	3100	3.520	124.30	20.60	0.810	53.5
KHB1248SHS	-R00 / -F00	48	32.0 to 80.0	0.35	16.80	3500	4.000	141.30	27.00	1.070	57.5
KHB1248EHS	-R00 / -F00	48	32.0 to 80.0	0.47	22.56	4100	4.680	165.30	38.20	1.500	61.5

\* Function type is optional.  
 \* The max. air flow and the speed are measured in free air ; max. air pressure is measured at zero air flow.  
 \* Noise is measured in anechoic chamber in free air, one meter from intake side.  
 \* All readings are typical values at rated voltage.  
 \* Specifications are subject to change without notice.