

PART NAME: KNOB SCALE: 1:1 DATE: 7/3/44 DR. BY JC

DAVIES MOLDING COMPANY
CAROL STREAM, ILLINOIS 60188

P/N 1400-W

THIS DRAWING IS THE PROPERTY OF DAVIES MOLDING COMPANY, IS SUBMITTED SOLELY AS A DESIGN OR ENGINEERING PROJECT. WE ACCEPT NO RESPONSIBILITY WHATSOEVER FOR THE PRACTICAL APPLICATION OF THE PIECES MADE TO THIS DESIGN.

BASE PART 1400-11

SET SCREW I0328

SCALE 2 : 1

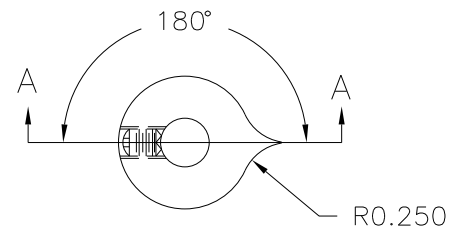
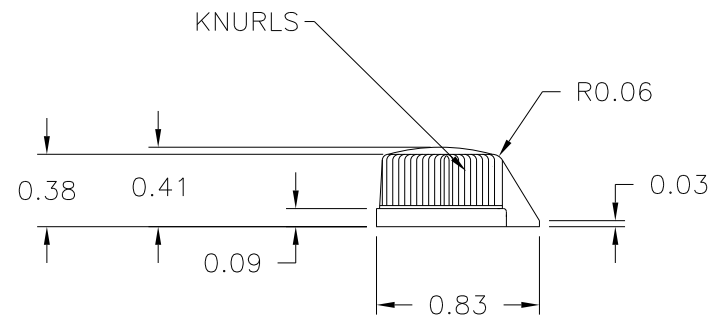
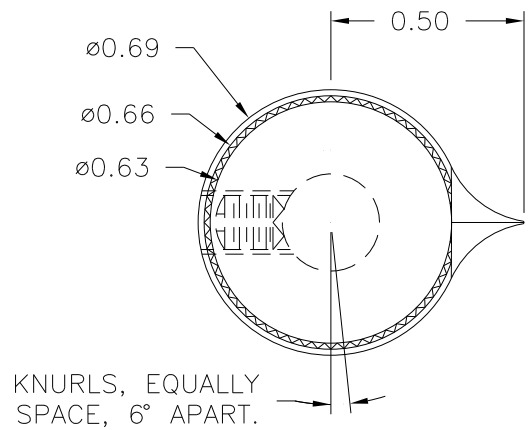

SECTION A-A

USE #28 DRILL (0.140), #8-32 TAP, #8-32 X 3/16 LG. CUP POINTED, SLOTTED TYPE, SET SCREW I0328 (1).

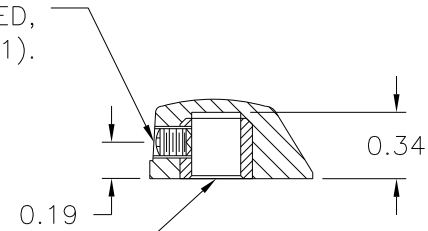

$\phi 0.253/0.252$, INSERT I0115 OR I0454, H.H. BRASS.

MATERIAL: G.P. PHENOLIC (B11)
COLOR: BLACK

TOLERANCES: UNLESS OTHERWISE SPECIFIED	DO NOT SCALE DRAWING	-	UPDATED/HAD TOOLBOX	ST	9/8/2000
DECIMALS: X.XXX ± .005 X.XX ± .015	MM: X.XX ± 0.15MM X.X ± 0.4MM	-	UPDATED DRAWING	HD	2/6/97
FRACTIONS ± 1/64	ANG. ± 1°	-	CAD/REDRAWN	HD	1/14/97
CHANGES					