

SECTION B-B

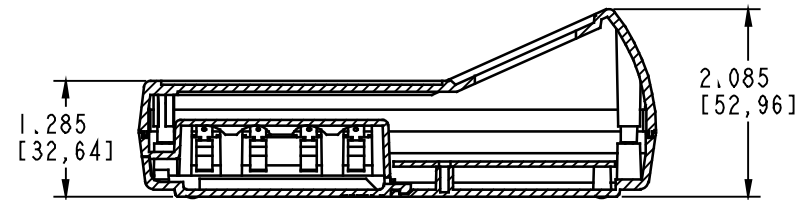

SECTION A-A

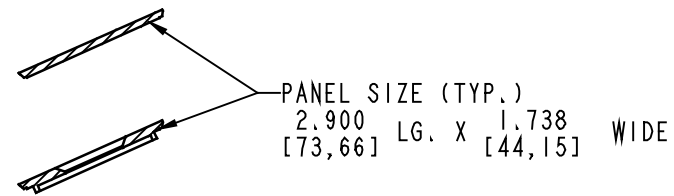
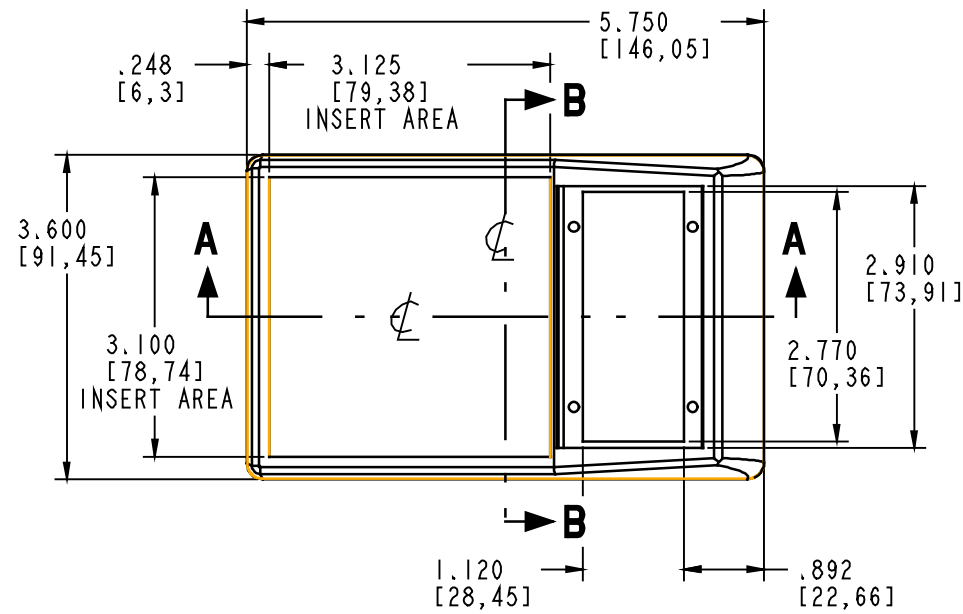
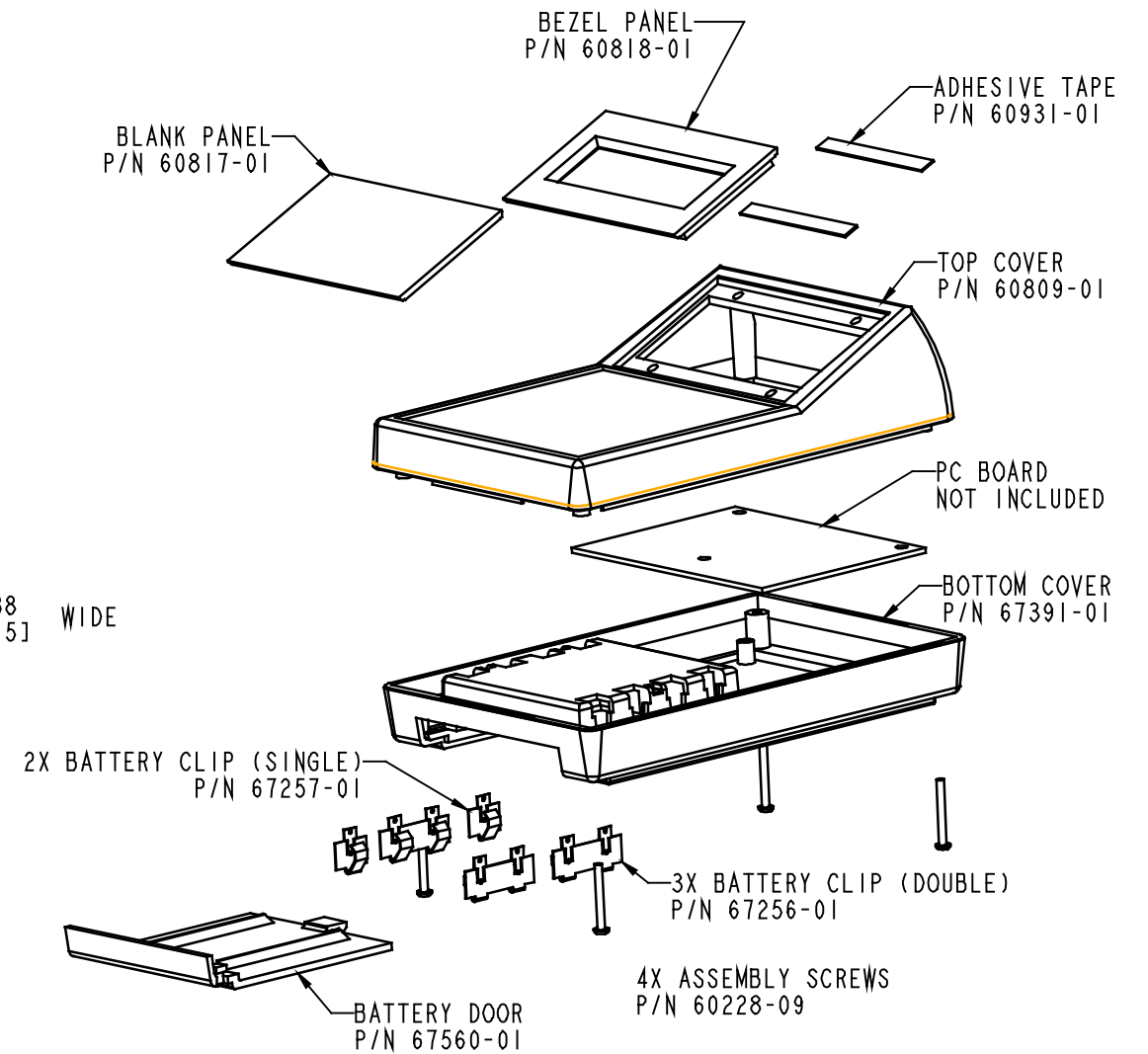
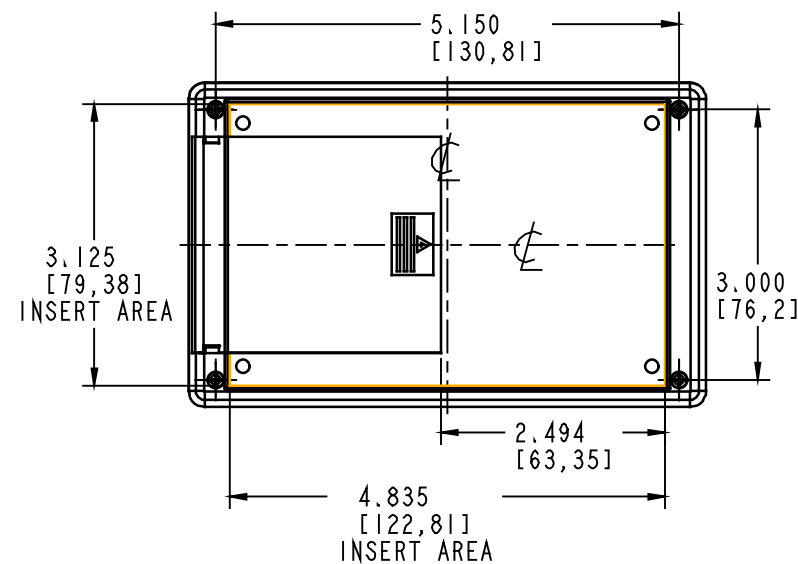
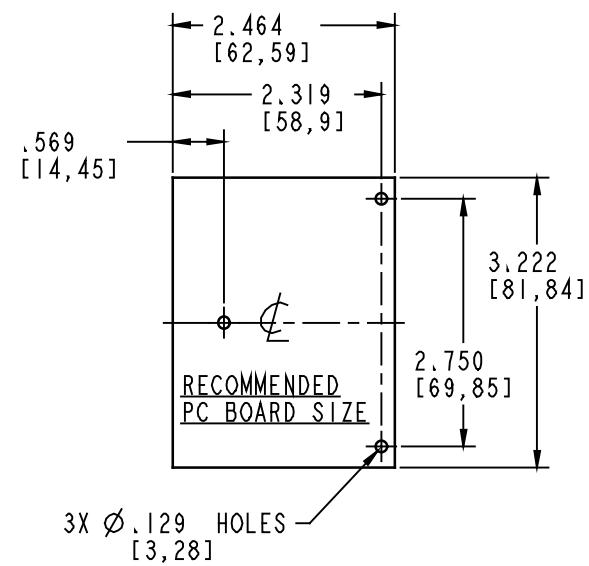

PACNTEC®
1-610-361-4200

HPS-4AA

VISIT **PACNTEC®**
ON THE WORLD WIDE WEB
www.pactecenclosures.com

COLOR / MATERIAL CODE		
COLOR	94HB	94VO
BLACK	000	028
P.C.BONE	039	060

DRAWING NUMBER	REV
69441	C