

1.8V Low-Power Open-Drain Output Comparator

Features:

- Propagation Delay at 1.8 V_{DD}:
56 ns (typical) High-to-Low
- Low Quiescent Current: 100 µA (typical)
- Input Offset Voltage: ±3 mV (typical)
- Rail-to-Rail Input: V_{SS} - 0.3V to V_{DD} + 0.3V
- Open-Drain Output
- Wide Supply Voltage Range: 1.8V to 5.5V
- Available in Single, Dual and Quad
- Packages: SC70, SOT-23-5, SOIC, MSOP, TSSOP

Typical Applications:

- Laptop Computers
- Mobile Phones
- Hand-held Electronics
- RC Timers
- Alarm and Monitoring Circuits
- Window Comparators
- Multivibrators

Design Aids:

- Microchip Advanced Part Selector (MAPS)
- Analog Demonstration and Evaluation Boards
- Application Notes
- SPICE Macro Model

Related Device:

Push-Pull Output: MCP6561/1R/1U/2/4

Typical Application

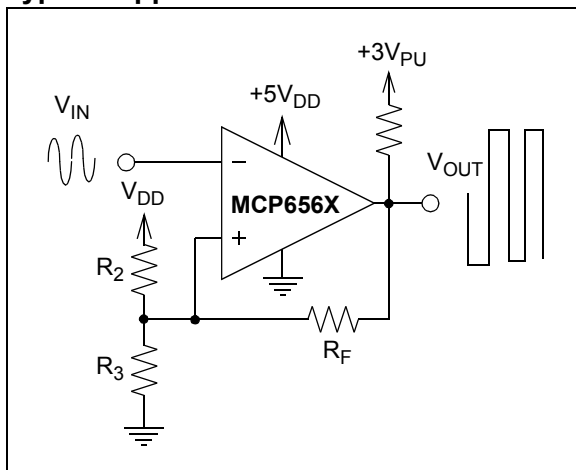

Description:

The Microchip MCP6566/6R/6U/7/9 family of open-drain output comparators are offered in single, dual and quad configurations.

These comparators are optimized for low-power 1.8V, single-supply applications with greater than rail-to-rail input operation. The internal input hysteresis eliminates output switching due to internal input noise voltage, reducing current draw.

The open-drain output of the MCP6566/6R/6U/7/9 family requires a pull-up resistor. It supports pull-up voltages that are above and below V_{DD}, which can be used to level shift. The output toggle frequency can reach a typical of 4 MHz (typical) while limiting supply current surges and dynamic power consumption during switching.

This family operates with single supply voltage of 1.8V to 5.5V while drawing less than 100 µA/comparator of quiescent current (typical).

Package Types

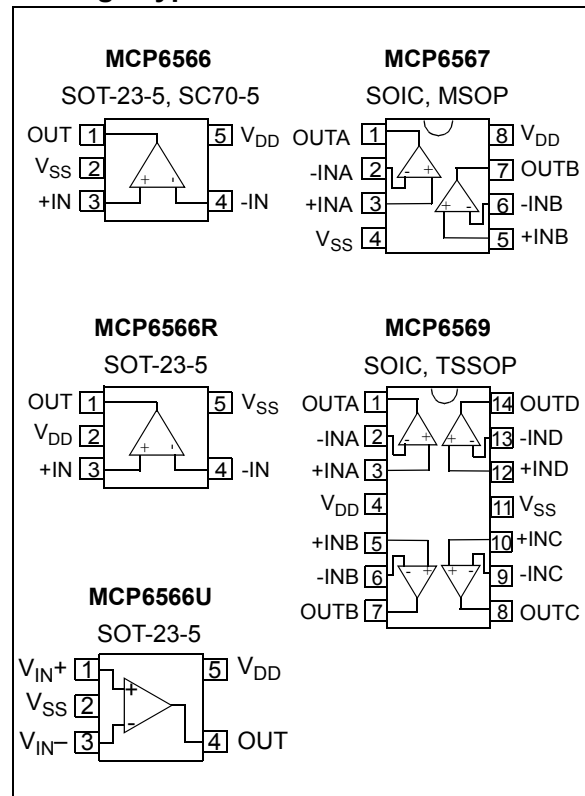

MCP6566/6R/6U/7/9

NOTES:

1.0 ELECTRICAL CHARACTERISTICS

1.1 Maximum Ratings †

$V_{DD} - V_{SS}$	6.5V
Open-Drain Output.....	$V_{SS} + 10.5V$
All other inputs and outputs.....	$V_{SS} - 0.3V$ to $V_{DD} + 0.3V$
Analog Input (V_{IN}) ††	$V_{SS} - 1.0V$ to $V_{DD} + 1.0V$
Difference Input voltage	$ V_{DD} - V_{SS} $
Output Short Circuit Current	± 25 mA
Current at Input Pins	± 2 mA
Current at Output and Supply Pins	± 50 mA
Storage temperature	$-65^{\circ}C$ to $+150^{\circ}C$
Ambient temp. with power applied	$-40^{\circ}C$ to $+125^{\circ}C$
Junction temp.....	$+150^{\circ}C$
ESD protection on all pins (HBM/MM).....	$\geq 4kV/300V$

† **Notice:** Stresses above those listed under “Maximum Ratings” may cause permanent damage to the device. This is a stress rating only and functional operation of the device at those or any other conditions above those indicated in the operational listings of this specification is not implied. Exposure to maximum rating conditions for extended periods may affect device reliability.

†† See [Section 4.1.2 “Input Voltage and Current Limits”](#)

DC CHARACTERISTICS

Electrical Characteristics: Unless otherwise indicated: $V_{DD} = +1.8V$ to $+5.5V$, $V_{SS} = GND$, $T_A = +25^{\circ}C$, $V_{IN+} = V_{DD}/2$, $V_{IN-} = V_{SS}$, and $R_{PULL-UP} = 20$ k Ω to $V_{PU} = V_{DD}$ (see [Figure 1-1](#)).

Parameters	Symbol	Min.	Typ.	Max.	Units	Conditions
Power Supply						
Supply Voltage	V_{DD}	1.8	—	5.5	V	
Quiescent Current per comparator	I_Q	60	100	130	μA	$I_{OUT} = 0$
Power Supply Rejection Ratio	PSRR	63	70	—	dB	$V_{CM} = V_{SS}$
Input						
Input Offset Voltage	V_{OS}	-10	± 3	+10	mV	$V_{CM} = V_{SS}$ (Note 1)
Input Offset Drift	$\Delta V_{OS}/\Delta T$	—	± 2	—	$\mu V/^{\circ}C$	$V_{CM} = V_{SS}$
Input Offset Current	I_{OS}	—	± 1	—	μA	$V_{CM} = V_{SS}$
Input Bias Current	I_B	—	1	—	μA	$T_A = +25^{\circ}C$, $V_{IN-} = V_{DD}/2$
		—	60	—	μA	$T_A = +85^{\circ}C$, $V_{IN-} = V_{DD}/2$
		—	1500	5000	μA	$T_A = +125^{\circ}C$, $V_{IN-} = V_{DD}/2$
Input Hysteresis Voltage	V_{HYST}	1.0	—	5.0	mV	$V_{CM} = V_{SS}$ (Notes 1, 2)
Input Hysteresis Linear Temp. Co.	TC_1	—	10	—	$\mu V/^{\circ}C$	
Input Hysteresis Quadratic Temp. Co.	TC_2	—	0.3	—	$\mu V/^{\circ}C^2$	
Common-Mode Input Voltage Range	V_{CMR}	$V_{SS}-0.2$	—	$V_{DD} + 0.2$	V	$V_{DD} = 1.8V$
		$V_{SS}-0.3$	—	$V_{DD} + 0.3$	V	$V_{DD} = 5.5V$
Common-Mode Rejection Ratio	CMRR	54	66	—	dB	$V_{CM} = -0.3V$ to $V_{DD}+0.3V$, $V_{DD} = 5.5V$
		50	63	—	dB	$V_{CM} = V_{DD}/2$ to $V_{DD}+0.3V$, $V_{DD} = 5.5V$
		54	65	—	dB	$V_{CM} = -0.3V$ to $V_{DD}/2$, $V_{DD} = 5.5V$
Common Mode Input Impedance	Z_{CM}	—	$10^{13} 4$	—	ΩpF	
Differential Input Impedance	Z_{DIFF}	—	$10^{13} 2$	—	ΩpF	

- Note 1:** The input offset voltage is the center of the input-referred trip points. The input hysteresis is the difference between the input-referred trip points.
- 2:** V_{HYST} at different temperatures is estimated using $V_{HYST}(T_A) = V_{HYST}@+25^{\circ}C + (T_A - 25^{\circ}C)TC_1 + (T_A - 25^{\circ}C)^2TC_2$.
- 3:** Limit the output current to Absolute Maximum Rating of 50 mA.
- 4:** The pull-up voltage for the open drain output V_{PULL_UP} can be as high as the absolute maximum rating of 10.5V. In this case, I_{OH_leak} can be higher than 1 μA (see [Figure 2-30](#)).

MCP6566/6R/6U/7/9

DC CHARACTERISTICS (CONTINUED)

Electrical Characteristics: Unless otherwise indicated: $V_{DD} = +1.8V$ to $+5.5V$, $V_{SS} = GND$, $T_A = +25^\circ C$, $V_{IN+} = V_{DD}/2$, $V_{IN-} = V_{SS}$, and $R_{PULL-UP} = 20\text{ k}\Omega$ to $V_{PU} = V_{DD}$ (see Figure 1-1).

Parameters	Symbol	Min.	Typ.	Max.	Units	Conditions
Push-Pull Output						
Pull-up Voltage	V_{PULL_UP}	1.6	—	5.5	V	
High-Level Output Voltage	V_{OH}	—	—	V_{PULL_UP}	V	(see Figure 1-1) (Notes 3, 4)
High-Level Output Current Leakage	I_{OH_leak}	—	—	1	μA	Note 4
Low-Level Output Voltage	V_{OL}	—	—	0.6	V	$I_{OUT} = 3\text{ mA}/8\text{ mA}$ @ $V_{DD} = 1.8V/5.5V$
Short Circuit Current (Notes 3)	I_{SC}	—	± 30	—	mA	Not to exceed Absolute Max. Rating
Output Pin Capacitance	C_{OUT}	—	8	—	pF	

- Note 1:** The input offset voltage is the center of the input-referred trip points. The input hysteresis is the difference between the input-referred trip points.
- Note 2:** V_{HYST} at different temperatures is estimated using $V_{HYST}(T_A) = V_{HYST}@+25^\circ C + (T_A - 25^\circ C) TC_1 + (T_A - 25^\circ C)^2 TC_2$.
- Note 3:** Limit the output current to Absolute Maximum Rating of 50 mA.
- Note 4:** The pull-up voltage for the open drain output V_{PULL_UP} can be as high as the absolute maximum rating of 10.5V. In this case, I_{OH_leak} can be higher than 1 μA (see Figure 2-30).

AC CHARACTERISTICS

Electrical Characteristics: Unless otherwise indicated, : Unless otherwise indicated, : $V_{DD} = +1.8V$ to $+5.5V$, $V_{SS} = GND$, $T_A = +25^\circ C$, $V_{IN+} = V_{DD}/2$, $V_{IN-} = V_{SS}$, $R_{PULL-UP} = 20\text{ k}\Omega$ to $V_{PU} = V_{DD}$, and $C_L = 25\text{ pf}$ (see Figure 1-1).

Parameters	Symbol	Min.	Typ.	Max.	Units	Conditions
Propagation Delay						
High-to-Low, 100 mV Overdrive	t_{PHL}	—	56	80	ns	$V_{CM} = V_{DD}/2$, $V_{DD} = 1.8V$
		—	34	80	ns	$V_{CM} = V_{DD}/2$, $V_{DD} = 5.5V$
Output						
Fall Time	t_F	—	20	—	ns	
Maximum Toggle Frequency	f_{TG}	—	4	—	MHz	$V_{DD} = 5.5V$
		—	2	—	MHz	$V_{DD} = 1.8V$
Input Voltage Noise	E_{NI}	—	350	—	μV_{P-P}	10 Hz to 10 MHz (Note 1)

- Note 1:** E_{NI} is based on SPICE simulation.
- Note 2:** Rise time t_R and t_{PLH} depend on the load (R_L and C_L). These specification are valid for the specified load only.

TEMPERATURE SPECIFICATIONS

Electrical Characteristics: Unless otherwise indicated: $V_{DD} = +1.8v$ to $+5.5v$ and $V_{SS} = GND$.

Parameters	Symbol	Min.	Typ.	Max.	Units	Conditions
Temperature Ranges						
Specified Temperature Range	T_A	-40	—	+125	$^\circ C$	
Operating Temperature Range	T_A	-40	—	+125	$^\circ C$	
Storage Temperature Range	T_A	-65	—	+150	$^\circ C$	
Thermal Package Resistances						
Thermal Resistance, SC70-5	θ_{JA}	—	331	—	$^\circ C/W$	
Thermal Resistance, SOT-23-5	θ_{JA}	—	201	—	$^\circ C/W$	
Thermal Resistance, 8L-MSOP	θ_{JA}	—	211	—	$^\circ C/W$	
Thermal Resistance, 8L-SOIC	θ_{JA}	—	149	—	$^\circ C/W$	
Thermal Resistance, 14L-SOIC	θ_{JA}	—	91	—	$^\circ C/W$	
Thermal Resistance, 14L-TSSOP	θ_{JA}	—	100	—	$^\circ C/W$	

1.2 Test Circuit Configuration

This test circuit configuration is used to determine the AC and DC specifications.

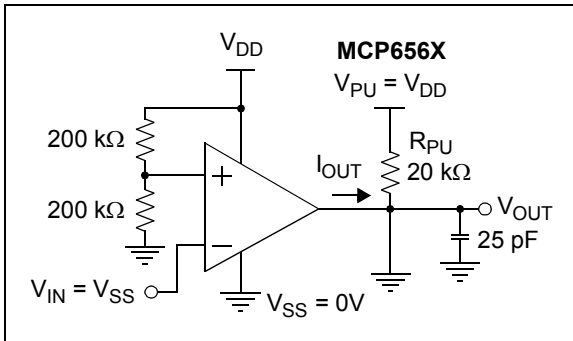

FIGURE 1-1: AC and DC Test Circuit for the Open-Drain Output Comparators.

MCP6566/6R/6U/7/9

NOTES:

2.0 TYPICAL PERFORMANCE CURVES

Note: The graphs and tables provided following this note are a statistical summary based on a limited number of samples and are provided for informational purposes only. The performance characteristics listed herein are not tested or guaranteed. In some graphs or tables, the data presented may be outside the specified operating range (i.e., outside specified power supply range) and therefore outside the warranted range.

Note: Unless otherwise indicated, $V_{DD} = +1.8V$ to $+5.5V$, $V_{SS} = GND$, $T_A = +25^\circ C$, $V_{IN+} = V_{DD}/2$, $V_{IN-} = GND$, $R_L = 20\text{ k}\Omega$ to $V_{PU} = V_{DD}$, and $C_L = 25\text{ pF}$.

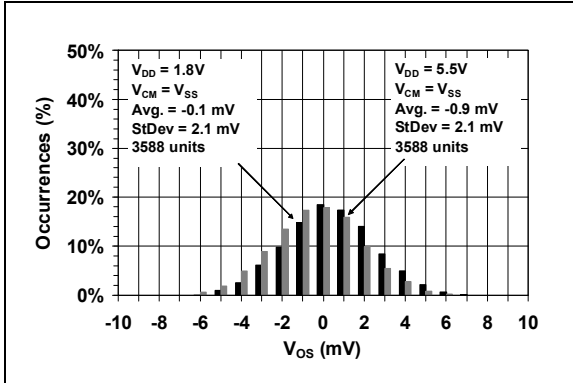

FIGURE 2-1: Input Offset Voltage.

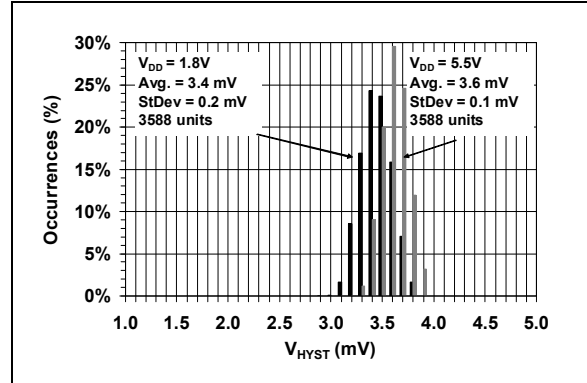

FIGURE 2-4: Input Hysteresis Voltage.

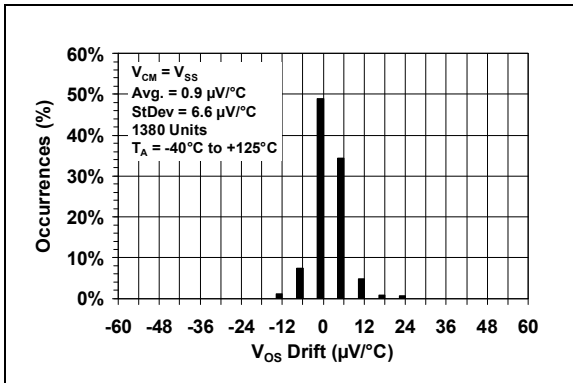

FIGURE 2-2: Input Offset Voltage Drift.

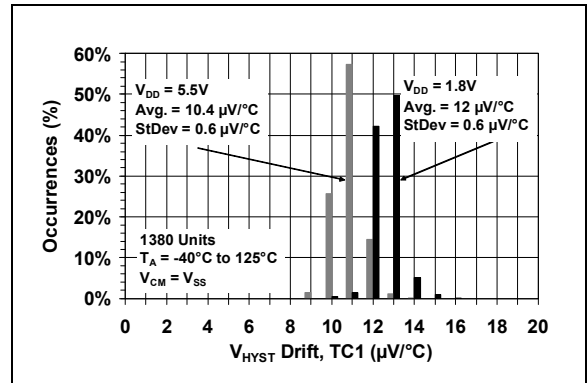

FIGURE 2-5: Input Hysteresis Voltage Drift – Linear Temp. Co. (TC1).

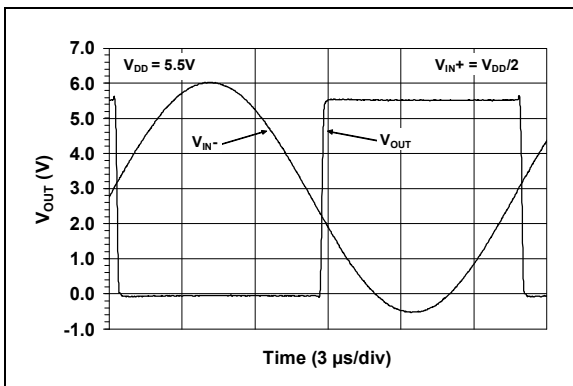

FIGURE 2-3: Input vs. Output Signal, No Phase Reversal.

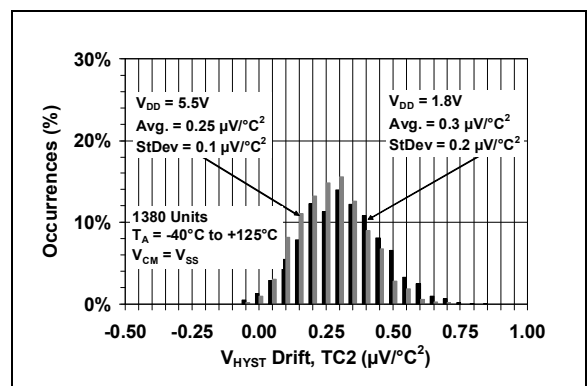

FIGURE 2-6: Input Hysteresis Voltage Drift – Quadratic Temp. Co. (TC2).

MCP6566/6R/6U/7/9

Note: Unless otherwise indicated, $V_{DD} = +1.8V$ to $+5.5V$, $V_{SS} = GND$, $T_A = +25^\circ C$, $V_{IN+} = V_{DD}/2$, $V_{IN-} = GND$, $R_L = 20\text{ k}\Omega$ to $V_{PU} = V_{DD}$, and $C_L = 25\text{ pF}$.

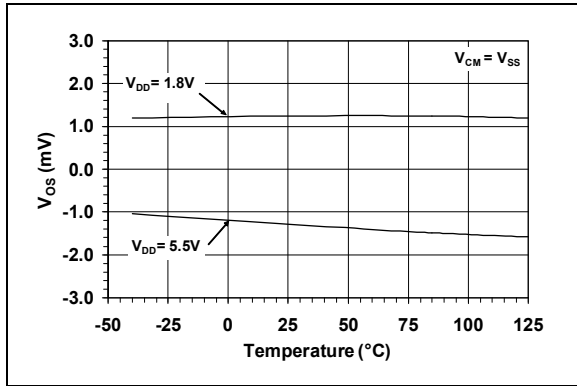

FIGURE 2-7: Input Offset Voltage vs. Temperature.

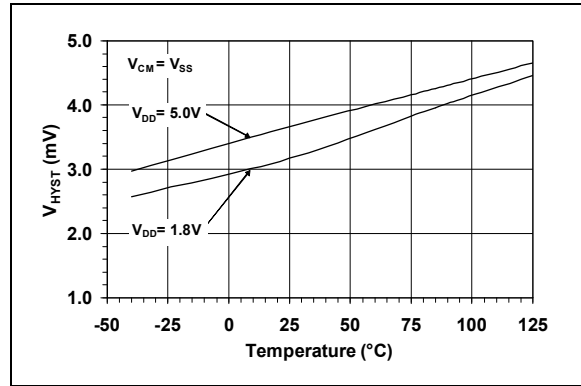

FIGURE 2-10: Input Hysteresis Voltage vs. Temperature.

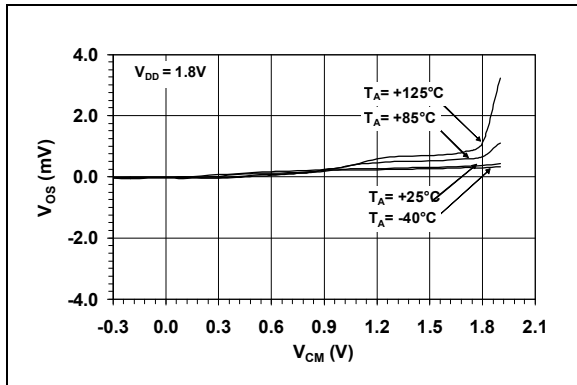

FIGURE 2-8: Input Offset Voltage vs. Common-mode Input Voltage.

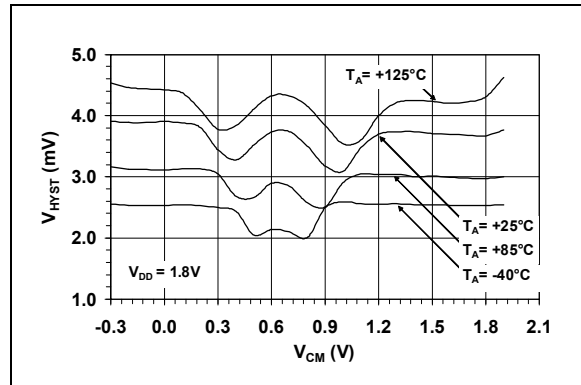

FIGURE 2-11: Input Hysteresis Voltage vs. Common-mode Input Voltage.

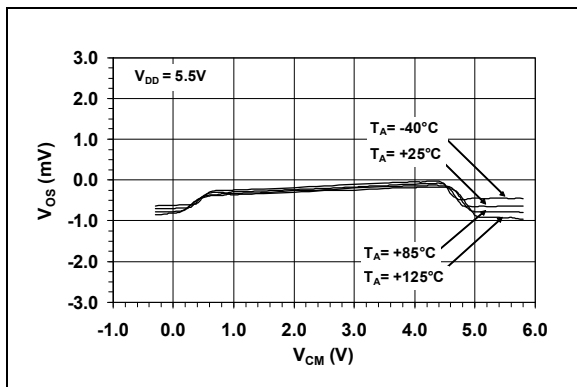

FIGURE 2-9: Input Offset Voltage vs. Common-mode Input Voltage.

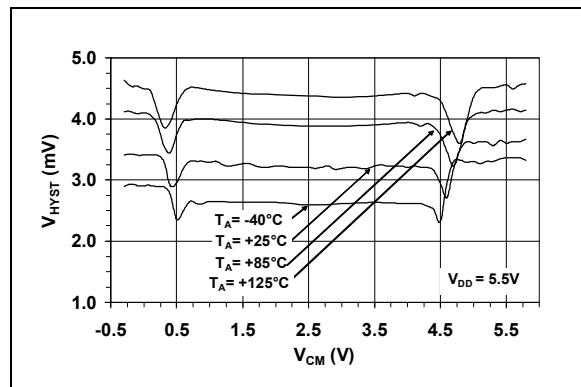

FIGURE 2-12: Input Hysteresis Voltage vs. Common-mode Input Voltage.

Note: Unless otherwise indicated, $V_{DD} = +1.8V$ to $+5.5V$, $V_{SS} = GND$, $T_A = +25^\circ C$, $V_{IN+} = V_{DD}/2$, $V_{IN-} = GND$, $R_L = 20\text{ k}\Omega$ to $V_{PU} = V_{DD}$, and $C_L = 25\text{ pF}$.

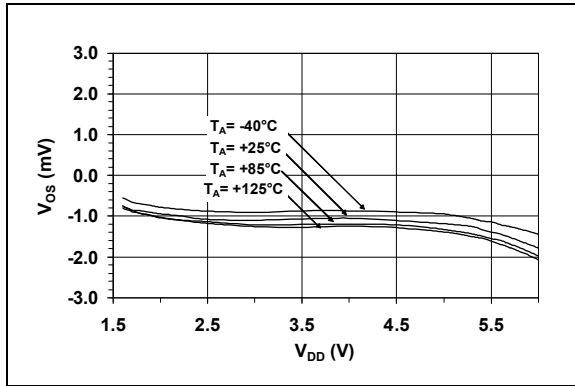

FIGURE 2-13: Input Offset Voltage vs. Supply Voltage vs. Temperature.

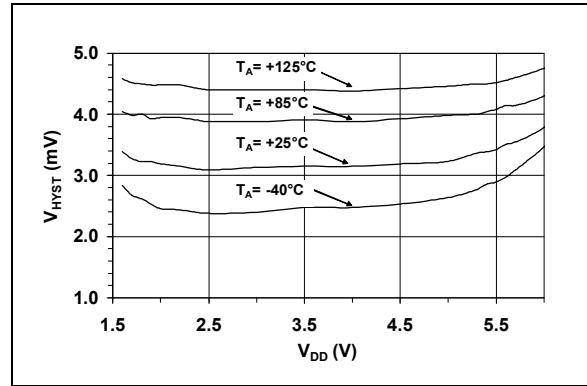

FIGURE 2-16: Input Hysteresis Voltage vs. Supply Voltage vs. Temperature.

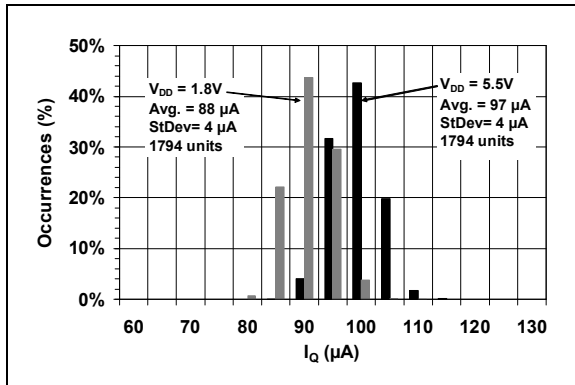

FIGURE 2-14: Quiescent Current.

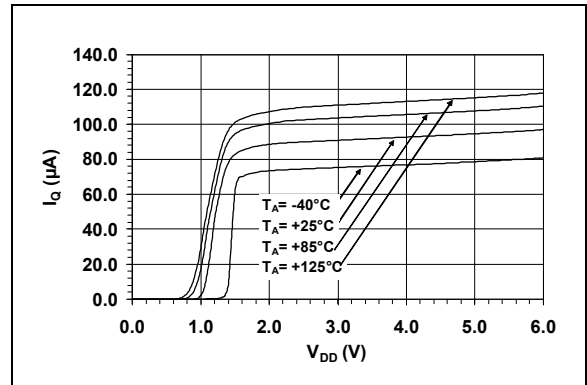

FIGURE 2-17: Quiescent Current vs. Supply Voltage vs. Temperature.

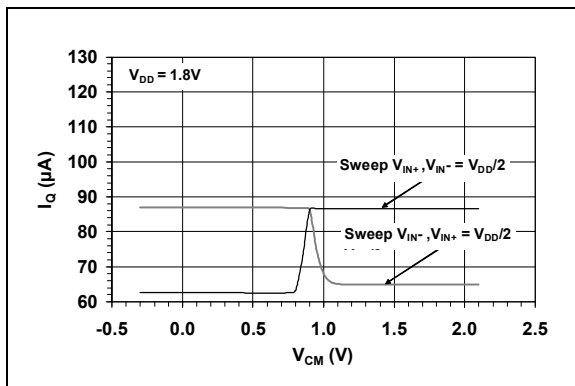

FIGURE 2-15: Quiescent Current vs. Common-mode Input Voltage.

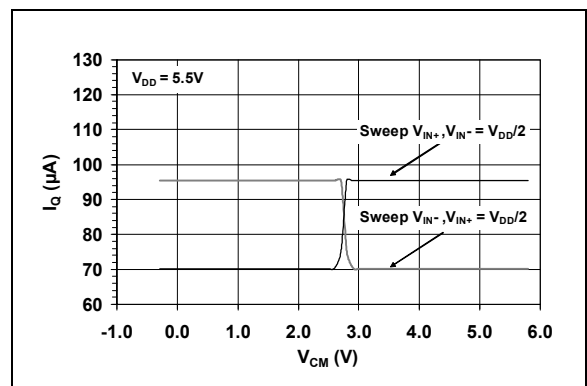

FIGURE 2-18: Quiescent Current vs. Common-mode Input Voltage.

MCP6566/6R/6U/7/9

Note: Unless otherwise indicated, $V_{DD} = +1.8\text{V}$ to $+5.5\text{V}$, $V_{SS} = \text{GND}$, $T_A = +25^\circ\text{C}$, $V_{IN+} = V_{DD}/2$, $V_{IN-} = \text{GND}$, $R_L = 20\text{ k}\Omega$ to $V_{PU} = V_{DD}$, and $C_L = 25\text{ pF}$.

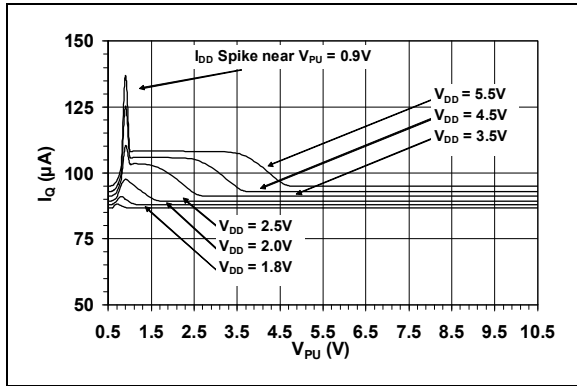

FIGURE 2-19: Quiescent Current vs. Pull-up Voltage.

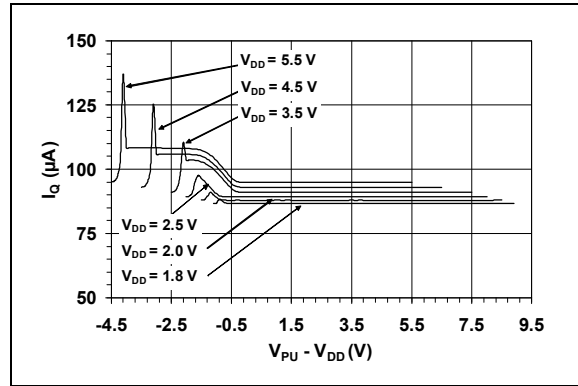

FIGURE 2-22: Quiescent Current vs. Pull-up to Supply Voltage Difference.

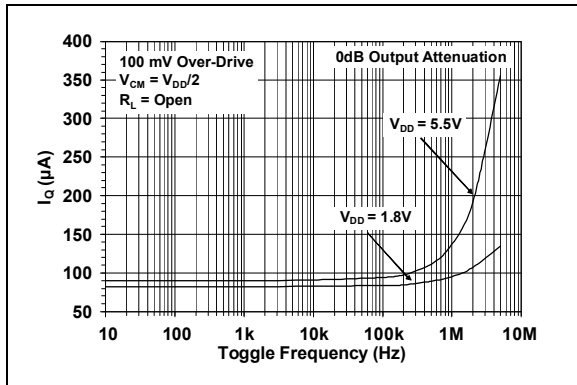

FIGURE 2-20: Quiescent Current vs. Toggle Frequency.

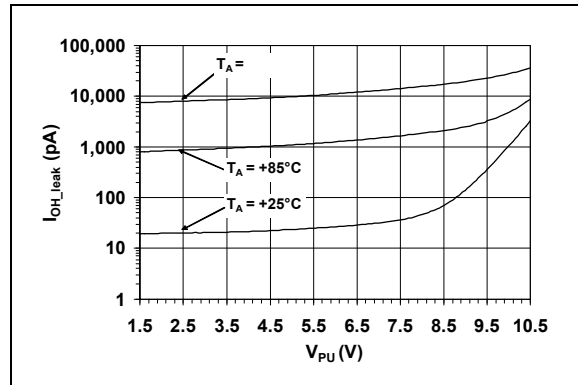

FIGURE 2-23: Output Leakage Current vs. Pull-up Voltage.

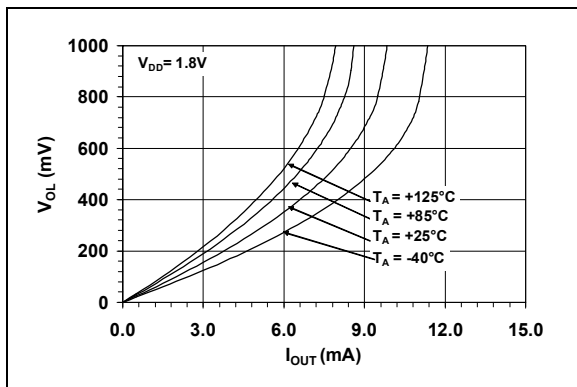

FIGURE 2-21: Output Headroom vs. Output Current.

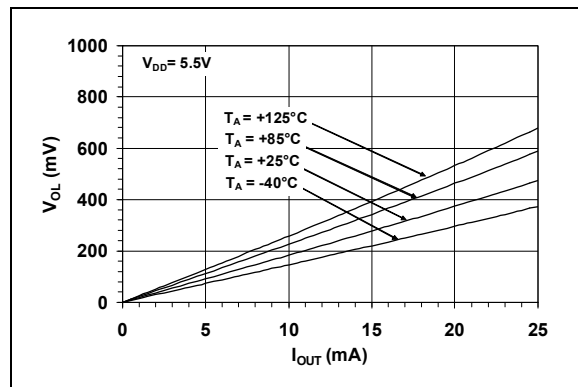

FIGURE 2-24: Output Headroom vs. Output Current.

MCP6566/6R/6U/7/9

Note: Unless otherwise indicated, $V_{DD} = +1.8V$ to $+5.5V$, $V_{SS} = GND$, $T_A = +25^\circ C$, $V_{IN+} = V_{DD}/2$, $V_{IN-} = GND$, $R_L = 20\text{ k}\Omega$ to $V_{PU} = V_{DD}$, and $C_L = 25\text{ pF}$.

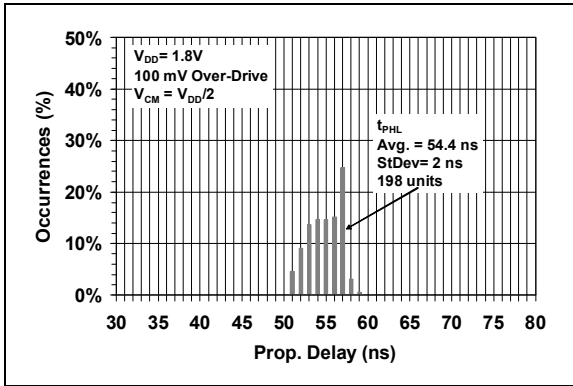

FIGURE 2-25: High-to-Low Propagation Delays.

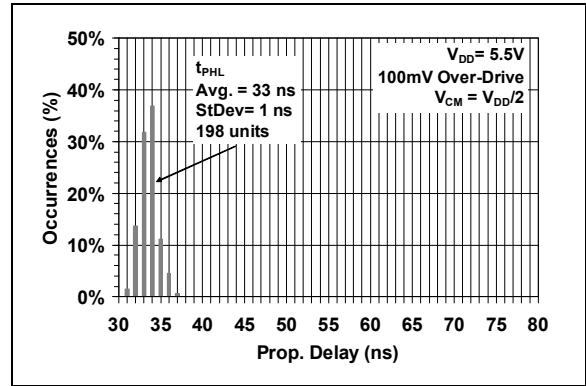

FIGURE 2-28: High-to-Low Propagation Delays.

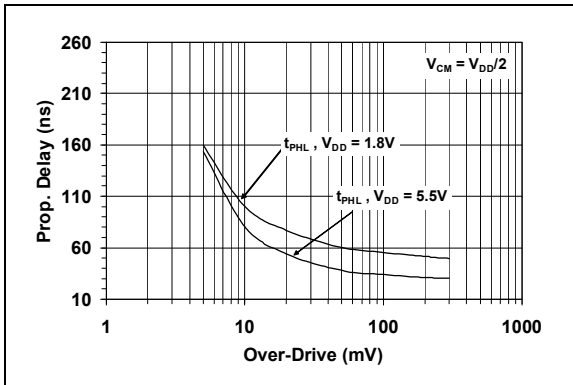

FIGURE 2-26: Propagation Delay vs. Input Over-Drive.

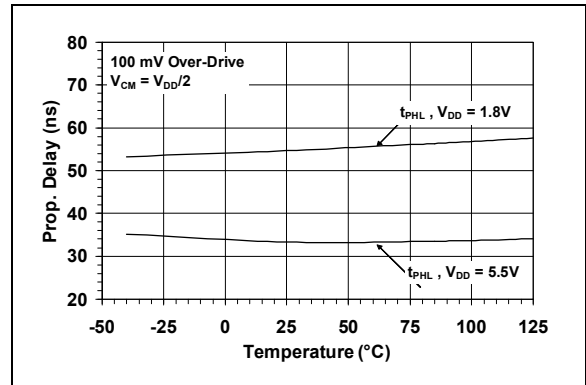

FIGURE 2-29: Propagation Delay vs. Temperature.

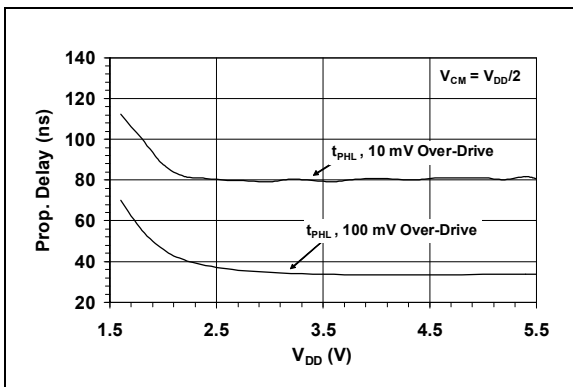

FIGURE 2-27: Propagation Delay vs. Supply Voltage.

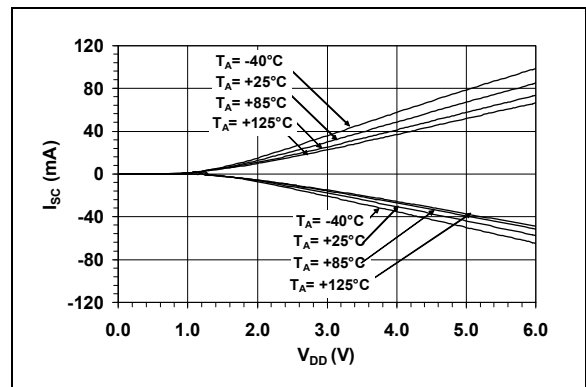

FIGURE 2-30: Short Circuit Current vs. Supply Voltage vs. Temperature.

MCP6566/6R/6U/7/9

Note: Unless otherwise indicated, $V_{DD} = +1.8V$ to $+5.5V$, $V_{SS} = GND$, $T_A = +25^\circ C$, $V_{IN+} = V_{DD}/2$, $V_{IN-} = GND$, $R_L = 20\text{ k}\Omega$ to $V_{PU} = V_{DD}$, and $C_L = 25\text{ pF}$.

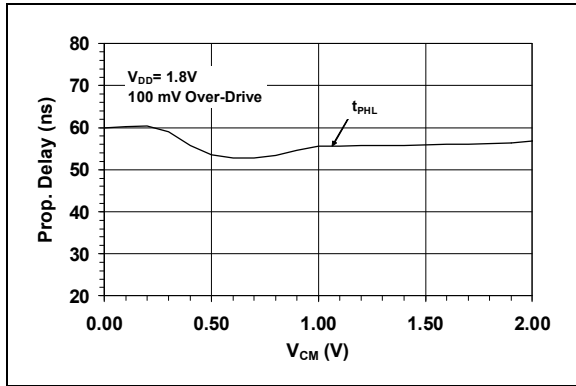

FIGURE 2-31: Propagation Delay vs. Common-mode Input Voltage.

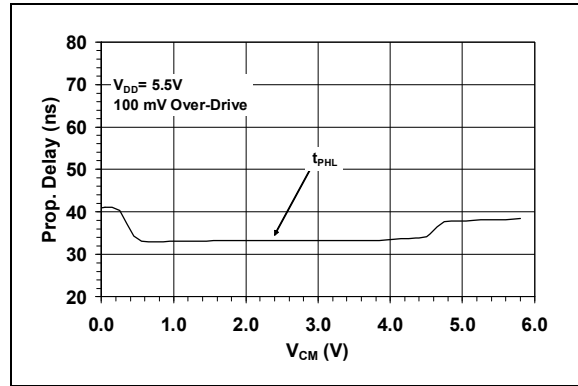

FIGURE 2-34: Propagation Delay vs. Common-mode Input Voltage.

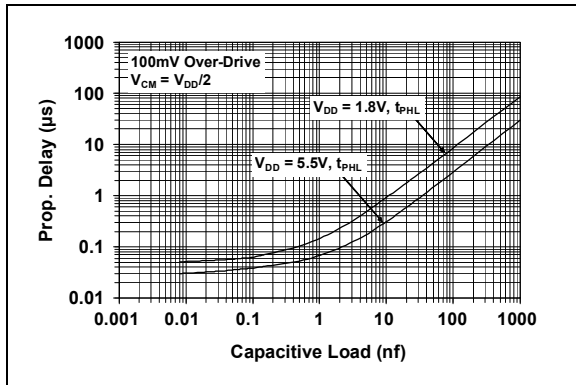

FIGURE 2-32: Propagation Delay vs. Capacitive Load.

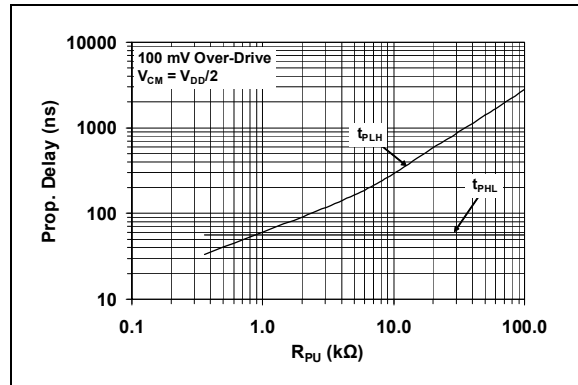

FIGURE 2-35: Propagation Delay vs. Pull-up Resistor.

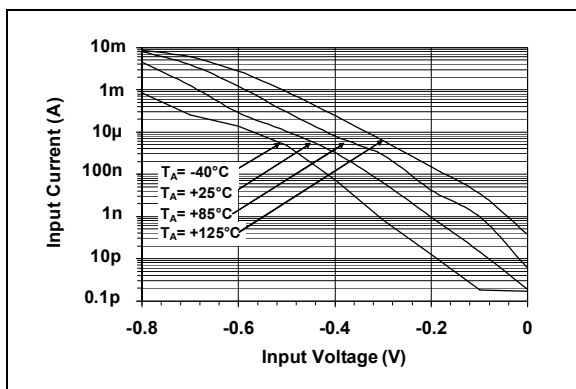

FIGURE 2-33: Input Bias Current vs. Input Voltage vs. Temperature.

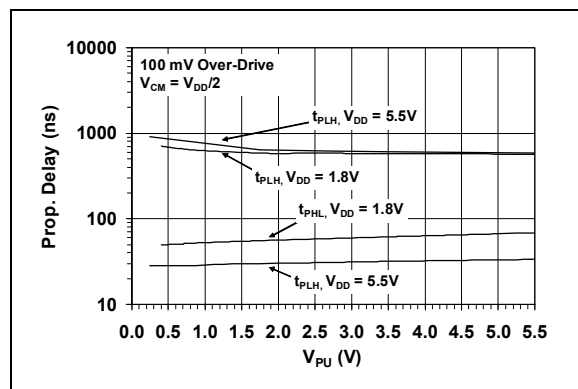

FIGURE 2-36: Propagation Delay vs. Pull-up Voltage.

Note: Unless otherwise indicated, $V_{DD} = +1.8V$ to $+5.5V$, $V_{SS} = GND$, $T_A = +25^\circ C$, $V_{IN+} = V_{DD}/2$, $V_{IN-} = GND$, $R_L = 20\text{ k}\Omega$ to $V_{PU} = V_{DD}$, and $C_L = 25\text{ pF}$.

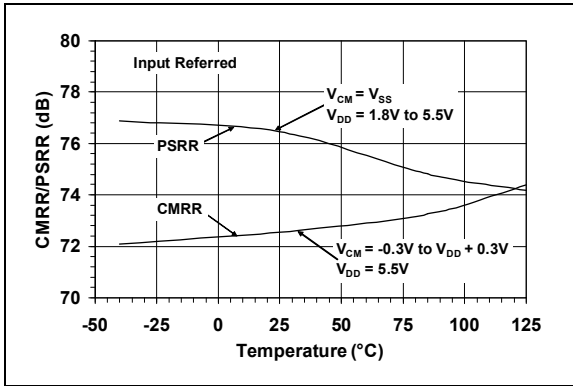

FIGURE 2-37: Common-mode Rejection Ratio and Power Supply Rejection Ratio vs. Temperature.

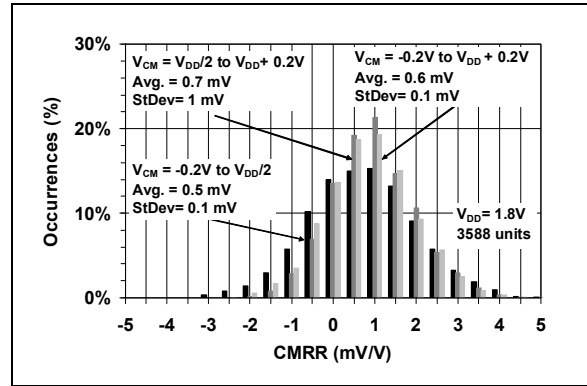

FIGURE 2-40: Common-mode Rejection Ratio (CMRR).

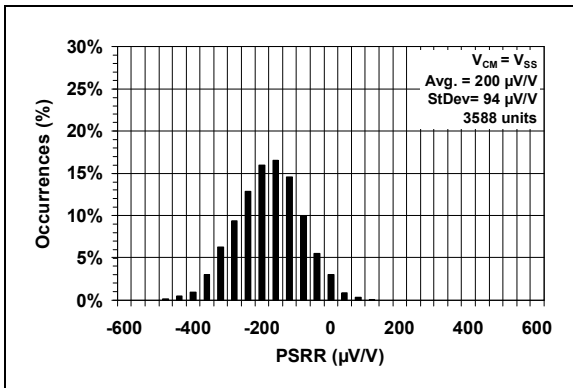

FIGURE 2-38: Power Supply Rejection Ratio (PSRR).

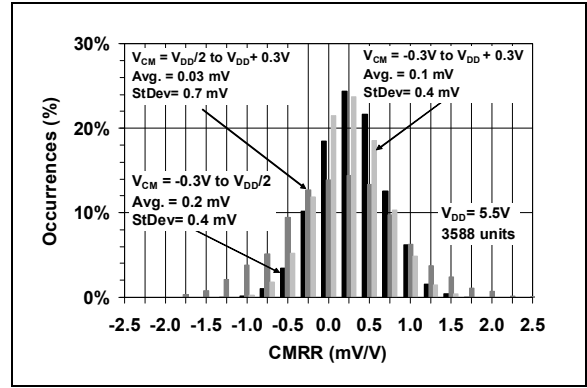

FIGURE 2-41: Common-mode Rejection Ratio (CMRR).

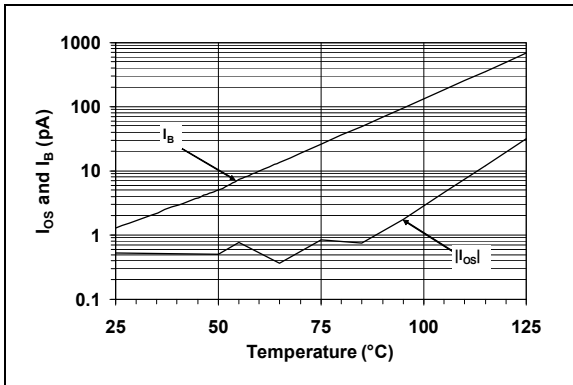

FIGURE 2-39: Input Offset Current and Input Bias Current vs. Temperature.

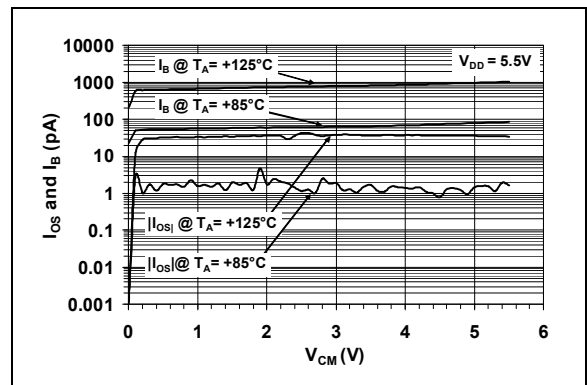

FIGURE 2-42: Input Offset Current and Input Bias Current vs. Common-mode Input Voltage vs. Temperature.

MCP6566/6R/6U/7/9

Note: Unless otherwise indicated, $V_{DD} = +1.8V$ to $+5.5V$, $V_{SS} = GND$, $T_A = +25^\circ C$, $V_{IN+} = V_{DD}/2$, $V_{IN-} = GND$, $R_L = 20\text{ k}\Omega$ to $V_{PU} = V_{DD}$, and $C_L = 25\text{ pF}$.

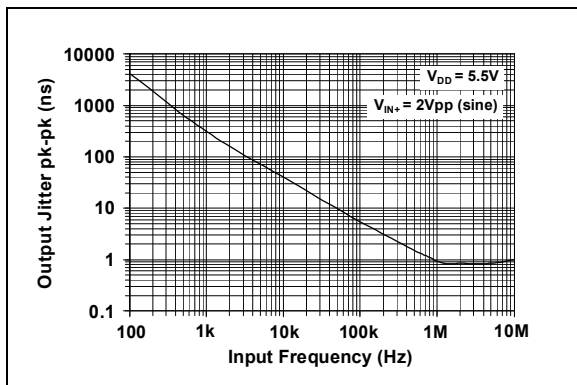

FIGURE 2-43: Output Jitter vs. Input Frequency.

3.0 PIN DESCRIPTIONS

Descriptions of the pins are listed in [Table 3-1](#).

TABLE 3-1: PIN FUNCTION TABLE

MCP6566	MCP6566R	MCP6566U	MCP6567	MCP6569	Symbol	Description
SC70-5, SOT-23-5	SOT-23-5	SOT-23-5	MSOP, SOIC	SOIC, TSSOP		
1	1	4	1	1	OUT, OUTA	Digital Output (comparator A)
4	4	3	2	2	V_{IN-} , V_{INA-}	Inverting Input (comparator A)
3	3	1	3	3	V_{IN+} , V_{INA+}	Non-inverting Input (comparator A)
5	2	5	8	4	V_{DD}	Positive Power Supply
—	—	—	5	5	V_{INB+}	Non-inverting Input (comparator B)
—	—	—	6	6	V_{INB-}	Inverting Input (comparator B)
—	—	—	7	7	OUTB	Digital Output (comparator B)
—	—	—	—	8	OUTC	Digital Output (comparator C)
—	—	—	—	9	V_{INC-}	Inverting Input (comparator C)
—	—	—	—	10	V_{INC+}	Non-inverting Input (comparator C)
2	5	2	4	11	V_{SS}	Negative Power Supply
—	—	—	—	12	V_{IND+}	Non-inverting Input (comparator D)
—	—	—	—	13	V_{IND-}	Inverting Input (comparator D)
—	—	—	—	14	OUTD	Digital Output (comparator D)

3.1 Analog Inputs

The comparator non-inverting and inverting inputs are high-impedance CMOS inputs with low bias currents.

3.2 Digital Outputs

The comparator outputs are CMOS, open-drain digital outputs. They are designed to make level shifting and wired-OR easy to implement.

3.3 Power Supply (V_{SS} and V_{DD})

The positive power supply pin (V_{DD}) is 1.8V to 5.5V higher than the negative power supply pin (V_{SS}). For normal operation, the other pins are at voltages between V_{SS} and V_{DD} .

Typically, these parts are used in a single (positive) supply configuration. In this case, V_{SS} is connected to ground and V_{DD} is connected to the supply. V_{DD} will need a local bypass capacitor (typically 0.01 μ F to 0.1 μ F) within 2 mm of the V_{DD} pin. These can share a bulk capacitor with nearby analog parts (within 100 mm), but it is not required.

MCP6566/6R/6U/7/9

NOTES:

4.0 APPLICATIONS INFORMATION

The MCP6566/6R/6U/7/9 family of open-drain output comparators are fabricated on Microchip's state-of-the-art CMOS process. They are suitable for a wide range of high speed applications that require low-power consumption.

4.1 Comparator Inputs

4.1.1 NORMAL OPERATION

The input stage of this family of devices uses two different input stages in parallel. This configuration provides three regions of operation, one operates at low input voltages, one at high input voltages, and one at mid input voltage. With this topology, the input voltage range is 0.3V above V_{DD} and 0.3V below V_{SS} , while providing low offset voltage throughout the common mode range. The input offset voltage is measured at both $V_{SS} - 0.3V$ and $V_{DD} + 0.3V$ to ensure proper operation.

The MCP6566/6R/6U/7/9 family has an internally-set hysteresis V_{HYST} , which is small enough to maintain input offset accuracy and large enough to eliminate output chattering caused by the comparator's own input noise voltage E_{NI} . Figure 4-1 depicts this behavior. Input offset voltage (V_{OS}) is the center (average) of the (input-referred) low-high and high-low trip points. Input hysteresis voltage (V_{HYST}) is the difference between the same trip points.

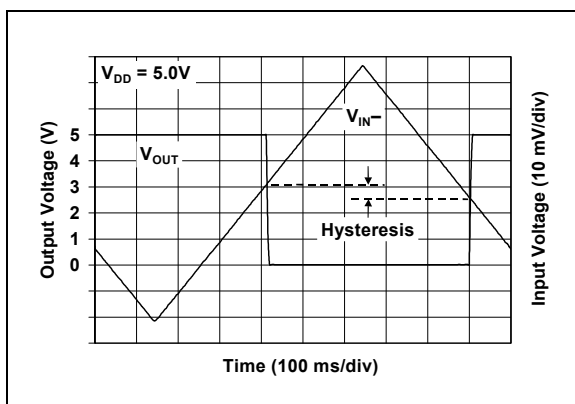

FIGURE 4-1: The MCP6566/6R/6U/7/9 comparators' internal hysteresis eliminates output chatter caused by input noise voltage.

4.1.2 INPUT VOLTAGE AND CURRENT LIMITS

The ESD protection on the inputs can be depicted as shown in Figure 4-2. This structure was chosen to protect the input transistors, and to minimize input bias current (I_B). The input ESD diodes clamp the inputs when they try to go more than one diode drop below V_{SS} . They also clamp any voltages that go too far above V_{DD} . The diodes' breakdown voltage is high enough to allow normal operation, but low enough to bypass ESD events within the specified limits.

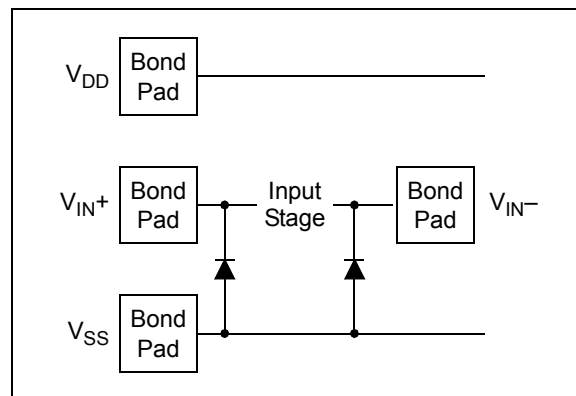

FIGURE 4-2: Simplified Analog Input ESD Structures.

In order to prevent damage and/or improper operation of these amplifiers, the circuits they are in must limit the currents (and voltages) at the V_{IN+} and V_{IN-} pins (see Section 1.1 "Maximum Ratings †" at the beginning of Section 1.0 "Electrical Characteristics"). Figure 4-3 shows the recommended approach to protecting these inputs. The internal ESD diodes prevent the input pins (V_{IN+} and V_{IN-}) from going too far below ground, and the resistors R_1 and R_2 limit the possible current drawn out of the input pin. Diodes D_1 and D_2 prevent the input pin (V_{IN+} and V_{IN-}) from going too far above V_{DD} . When implemented as shown, resistors R_1 and R_2 also limit the current through D_1 and D_2 .

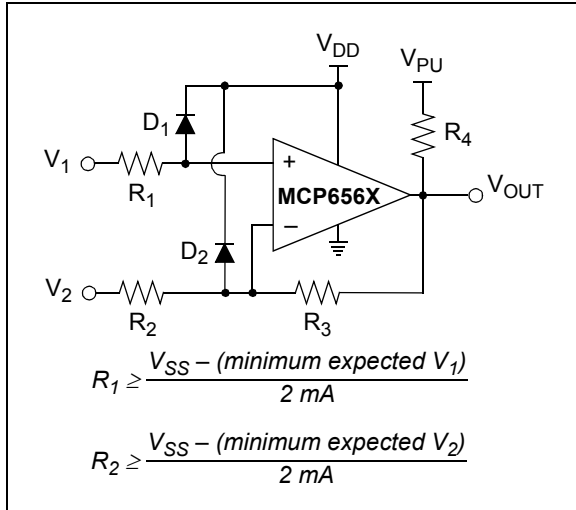

FIGURE 4-3: Protecting the Analog Inputs.

It is also possible to connect the diodes to the left of the resistors R_1 and R_2 . In this case, the currents through the diodes D_1 and D_2 need to be limited by some other mechanism. The resistor then serves as in-rush current limiter; the DC current into the input pins (V_{IN+} and V_{IN-}) should be very small.

A significant amount of current can flow out of the inputs when the common mode voltage (V_{CM}) is below ground (V_{SS}); see Figure 4-3. Applications that are high-impedance may need to limit the usable voltage range.

4.1.3 PHASE REVERSAL

The MCP6566/6R/6U/7/9 comparator family uses CMOS transistors at the input. They are designed to prevent phase inversion when the input pins exceed the supply voltages. Figure 2-3 shows an input voltage exceeding both supplies with no resulting phase inversion.

4.2 Open-Drain Output

The open-drain output is designed to make level-shifting and wired-OR logic easy to implement. The output stage minimizes switching current (shoot-through current from supply-to-supply) when the output changes state. See Figures 2-15, 2-18, 2-35 and 2-36, for more information.

4.3 Externally Set Hysteresis

Greater flexibility in selecting hysteresis (or input trip points) is achieved by using external resistors. Hysteresis reduces output chattering when one input is slowly moving past the other. It also helps in systems in which it is best not to cycle between high and low states too frequently (e.g., air conditioner thermostatic control). Output chatter also increases the dynamic supply current.

4.3.1 NON-INVERTING CIRCUIT

Figure 4-4 shows a non-inverting circuit for single-supply applications using just two resistors. The resulting hysteresis diagram is shown in Figure 4-5.

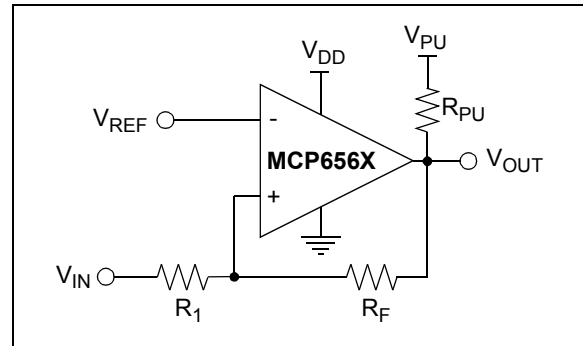

FIGURE 4-4: Non-Inverting Circuit with Hysteresis for Single-Supply.

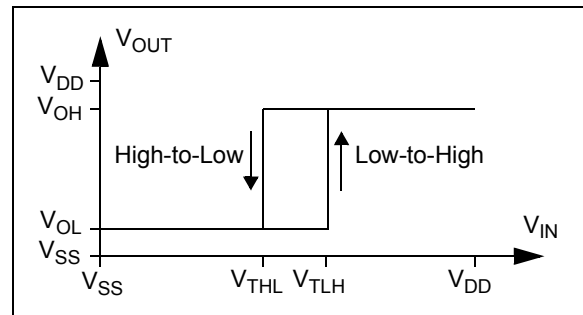

FIGURE 4-5: Hysteresis Diagram for the Non-Inverting Circuit.

The trip points for Figures 4-4 and 4-5 are:

EQUATION 4-1:

$$V_{TLH} = V_{REF} \left(1 + \frac{R_I}{R_F} \right) - V_{OL} \left(\frac{R_I}{R_F} \right)$$

$$V_{THL} = V_{REF} \left(1 + \frac{R_I}{R_F} \right) - V_{OH} \left(\frac{R_I}{R_F} \right)$$

Where:

- V_{TLH} = trip voltage from low-to-high
- V_{THL} = trip voltage from high-to-low

4.3.2 INVERTING CIRCUIT

Figure 4-6 shows an inverting circuit for single-supply using three resistors. The resulting hysteresis diagram is shown in Figure 4-7.

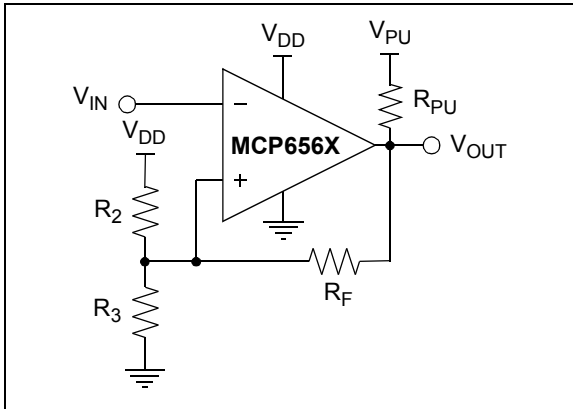

FIGURE 4-6: Inverting Circuit with Hysteresis.

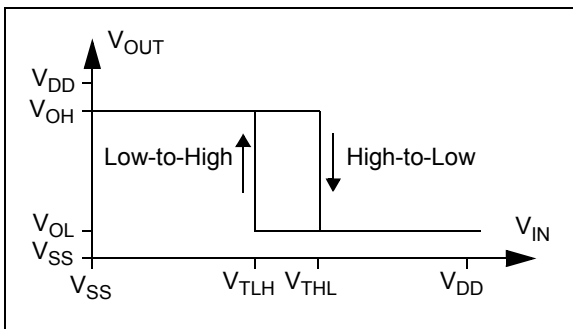

FIGURE 4-7: Hysteresis Diagram for the Inverting Circuit.

In order to determine the trip voltages (V_{THL} and V_{TLH}) for the circuit shown in Figure 4-6, R_2 and R_3 can be simplified to the Thevenin equivalent circuit with respect to V_{DD} , as shown in Figure 4-8.

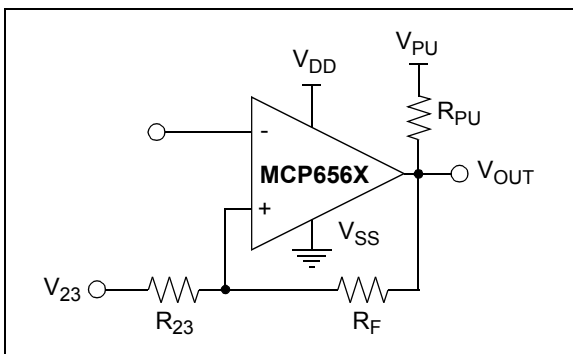

FIGURE 4-8: Thevenin Equivalent Circuit.

Where:

$$R_{23} = \frac{R_2 R_3}{R_2 + R_3}$$

$$V_{23} = \frac{R_3}{R_2 + R_3} \times V_{DD}$$

Using this simplified circuit, the trip voltage can be calculated using the following equation:

EQUATION 4-2:

$$V_{THL} = V_{OH} \left(\frac{R_{23}}{R_{23} + R_F} \right) + V_{23} \left(\frac{R_F}{R_{23} + R_F} \right)$$

$$V_{TLH} = V_{OL} \left(\frac{R_{23}}{R_{23} + R_F} \right) + V_{23} \left(\frac{R_F}{R_{23} + R_F} \right)$$

Where:

V_{TLH} = trip voltage from low-to-high

V_{THL} = trip voltage from high-to-low

Figure 2-21 and Figure 2-24 can be used to determine typical values for V_{OH} and V_{OL} .

4.4 Bypass Capacitors

With this family of comparators, the power supply pin (V_{DD} for single supply) should have a local bypass capacitor (i.e., 0.01 μF to 0.1 μF) within 2 mm for good edge rate performance.

4.5 Capacitive Loads

Reasonable capacitive loads (e.g., logic gates) have little impact on propagation delay (see Figure 2-32). The supply current increases with increasing toggle frequency (Figure 2-20), especially with higher capacitive loads. The output slew rate and propagation delay performance will be reduced with higher capacitive loads.

MCP6566/6R/6U/7/9

4.6 PCB Surface Leakage

In applications where low input bias current is critical, PCB (Printed Circuit Board) surface leakage effects need to be considered. Surface leakage is caused by humidity, dust or other contamination on the board. Under low humidity conditions, a typical resistance between nearby traces is $10^{12}\Omega$. A 5V difference would cause 5 pA of current to flow. This is greater than the MCP6566/6R/6U/7/9 family's bias current at +25°C (1 pA, typical).

The easiest way to reduce surface leakage is to use a guard ring around sensitive pins (or traces). The guard ring is biased at the same voltage as the sensitive pin. An example of this type of layout is shown in Figure 4-9.

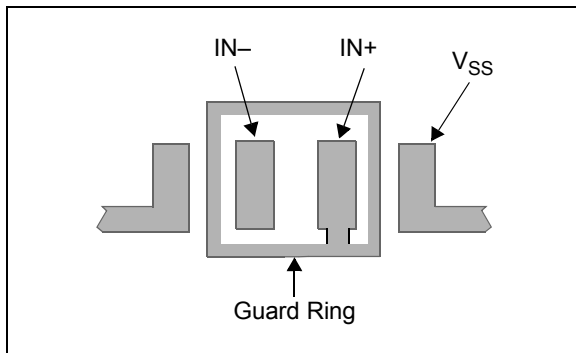

FIGURE 4-9: Example Guard Ring Layout for Inverting Circuit.

1. Inverting Configuration (Figures 4-6 and 4-9):
 - a) Connect the guard ring to the non-inverting input pin (V_{IN+}). This biases the guard ring to the same reference voltage as the comparator (e.g., $V_{DD}/2$ or ground).
 - b) Connect the inverting pin (V_{IN-}) to the input pad without touching the guard ring.
2. Non-inverting Configuration (Figure 4-4):
 - a) Connect the non-inverting pin (V_{IN+}) to the input pad without touching the guard ring.
 - b) Connect the guard ring to the inverting input pin (V_{IN-}).

4.7 PCB Layout Technique

When designing the PCB layout, it is critical to note that analog and digital signal traces are adequately separated to prevent signal coupling. If the comparator output trace is at close proximity to the input traces, then large output voltage changes from, V_{SS} to V_{DD} or visa versa, may couple to the inputs and cause the device output to oscillate. To prevent such oscillation, the output traces must be routed away from the input pins. The SC70-5 and SOT-23-5 are relatively immune because the output pin OUT (pin 1) is separated by the power pin V_{DD}/V_{SS} (pin 2) from the input pin +IN (as long as the analog and digital traces remain separated throughout the PCB). However, the pinouts for the dual and quad packages (SOIC, MSOP, TSSOP) have OUT and -IN pins (pin 1 and 2) close to each other. The recommended layout for these packages is shown in Figure 4-10.

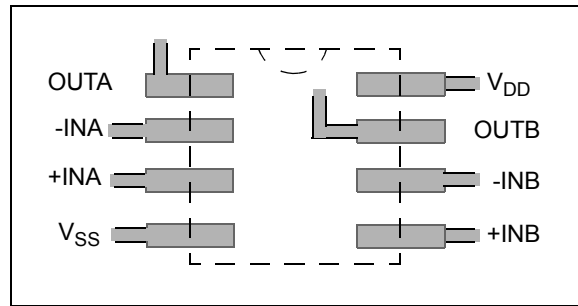

FIGURE 4-10: Recommended Layout.

4.8 Unused Comparators

An unused amplifier in a quad package (MCP6569) should be configured as shown in Figure 4-11. This circuit prevents the output from toggling and causing crosstalk. It uses the minimum number of components and draws minimal current (see Figure 2-15 and Figure 2-15).

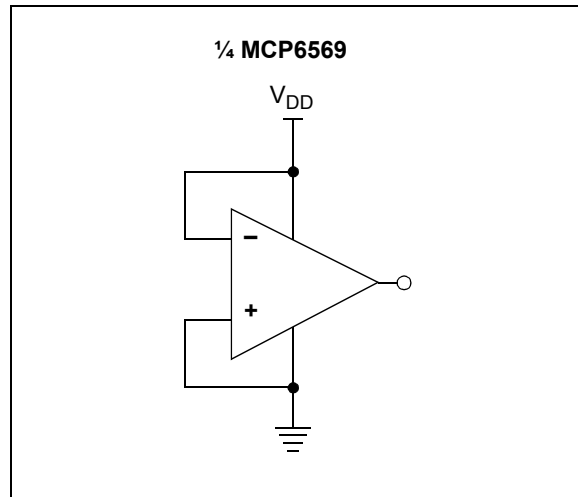

FIGURE 4-11: Unused Comparators.

4.9 Typical Applications

4.9.1 PRECISE COMPARATOR

Some applications require higher DC precision. An easy way to solve this problem is to use an amplifier (such as the MCP6291) to gain-up the input signal before it reaches the comparator. Figure 4-12 shows an example of this approach.

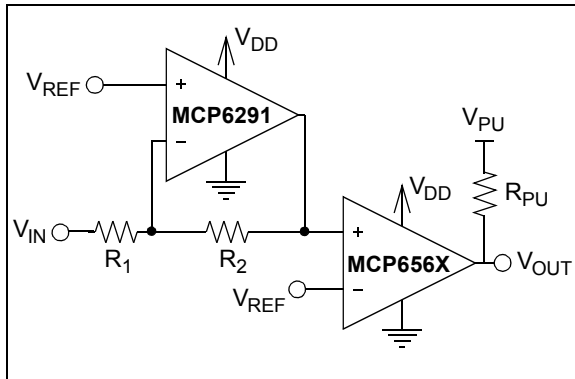

FIGURE 4-12: Precise Inverting Comparator.

4.9.2 WINDOWED COMPARATOR

Figure 4-13 shows one approach to designing a windowed comparator. The AND gate produces a logic '1' when the input voltage is between V_{RB} and V_{RT} (where $V_{RT} > V_{RB}$).

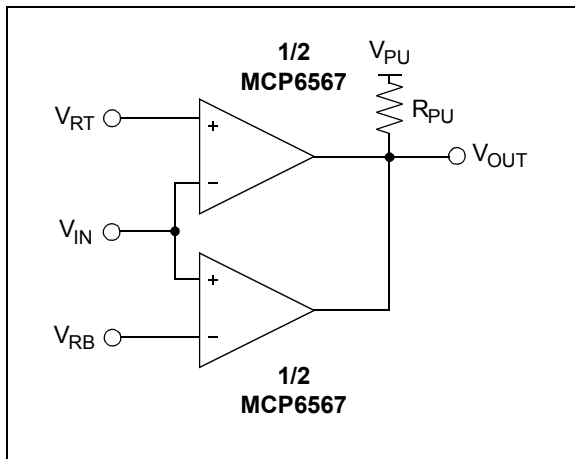

FIGURE 4-13: Windowed Comparator.

4.9.3 BISTABLE MULTIVIBRATOR

A simple bistable multivibrator design is shown in Figure 4-14. V_{REF} needs to be between the power supplies ($V_{SS} = GND$ and V_{DD}) to achieve oscillation. The output duty cycle changes with V_{REF} .

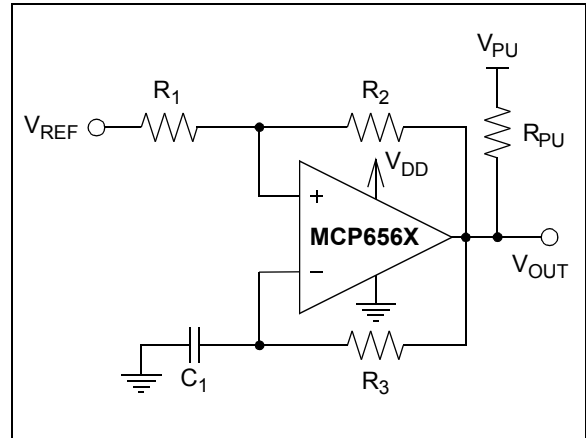

FIGURE 4-14: Bistable Multivibrator.

MCP6566/6R/6U/7/9

NOTES:

5.0 DESIGN AIDS

5.1 Microchip Advanced Part Selector (MAPS)

MAPS is a software tool that helps semiconductor professionals efficiently identify Microchip devices that fit a particular design requirement.

Available at no cost from the Microchip web site at www.microchip.com/maps, the MAPS is an overall selection tool for Microchip's product portfolio that includes Analog, Memory, MCU and DSC devices. Using this tool you can define a filter to sort features for a parametric search of devices and export side-by-side technical comparison reports. Helpful links are also provided for data sheets, purchase, and sampling of Microchip parts.

5.2 Analog Demonstration and Evaluation Boards

Microchip offers a broad spectrum of Analog Demonstration and Evaluation Boards that are designed to help you achieve faster time to market.

For a listing of these boards and their corresponding user's guides and technical information, visit the Microchip web site at www.microchip.com/analogtools. Three of the boards that are especially useful are:

- 8-Pin SOIC/MSOP/TSSOP/DIP Evaluation Board, P/N SOIC8EV
- 14-Pin SOIC/TSSOP/DIP Evaluation Board, P/N SOIC14EV
- 5/6-Pin SOT23 Evaluation Board, P/N VSUPEV2

5.3 Application Notes

The following Microchip Application Note is available on the Microchip web site at www.microchip.com and is recommended as a supplemental reference resource:

AN895 – “*Oscillator Circuits for RTD Temperature Sensors*” (DS00000895).

5.4 SPICE Macro Model

The latest SPICE macro model for the MCP6566/7/9 op amp is available on the Microchip web site at www.microchip.com. The model was written and tested in the official Cadence® (OrCAD®) PSpice®. For the other simulators, translation may be required.

The model covers a wide aspect of the comparator's electrical specifications. Not only does the model cover voltage, current and resistance of the comparator, but it also covers the temperature and the noise effects on the behavior of the comparator. The model has not been verified outside of the specification range listed in the comparator data sheet. The model behaviors under these conditions cannot ensure it will match the actual comparator performance. Moreover, the model is intended to be an initial design tool. Bench testing is a very important part of any design and cannot be replaced with simulations. Also, simulation results using this macro model need to be validated by comparing them to the data sheet specifications and characteristic curves.

MCP6566/6R/6U/7/9

NOTES:

6.0 PACKAGING INFORMATION

6.1 Package Marking Information

5-Lead SC70 (MCP6566)

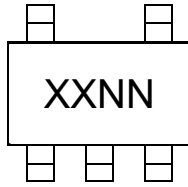

Example:

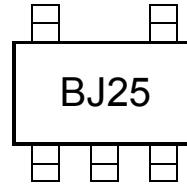

5-Lead SOT-23 (MCP6566, MCP6566R)

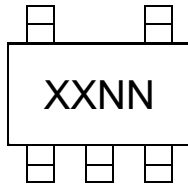

Device	Code
MCP6566T	JYNN
MCP6566RT	JZNN
MCP6566UT	WLNN

Note: Applies to 5-Lead SOT-23.

Example:

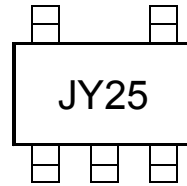

8-Lead MSOP (MCP6567)

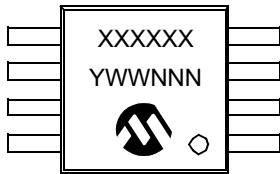

Example:

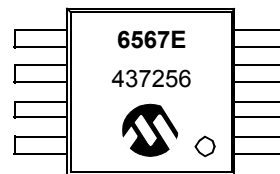

8-Lead SOIC (150 mil) (MCP6567)

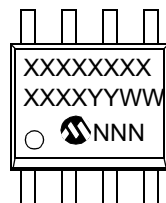

Example:

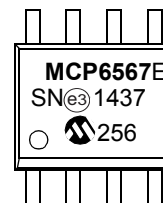

Legend:	XX...X	Customer-specific information
	Y	Year code (last digit of calendar year)
	YY	Year code (last 2 digits of calendar year)
	WW	Week code (week of January 1 is week '01')
	NNN	Alphanumeric traceability code
	(e3)	Pb-free JEDEC designator for Matte Tin (Sn)
	*	This package is Pb-free. The Pb-free JEDEC designator (e3) can be found on the outer packaging for this package.

Note: In the event the full Microchip part number cannot be marked on one line, it will be carried over to the next line, thus limiting the number of available characters for customer-specific information.

MCP6566/6R/6U/7/9

Package Marking Information (Continued)

14-Lead SOIC (150 mil) (MCP6569)

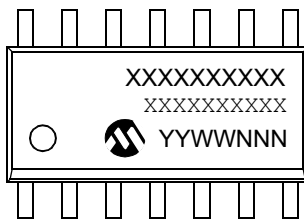

Example:

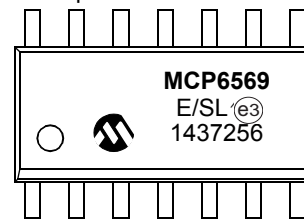

14-Lead TSSOP (MCP6569)

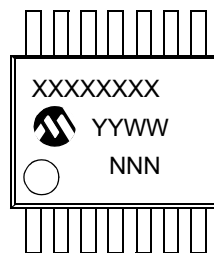

Example:

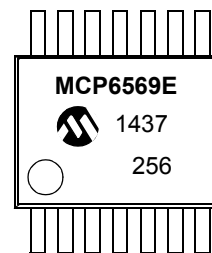

5-Lead Plastic Small Outline Transistor (LT) [SC70]

Note: For the most current package drawings, please see the Microchip Packaging Specification located at <http://www.microchip.com/packaging>

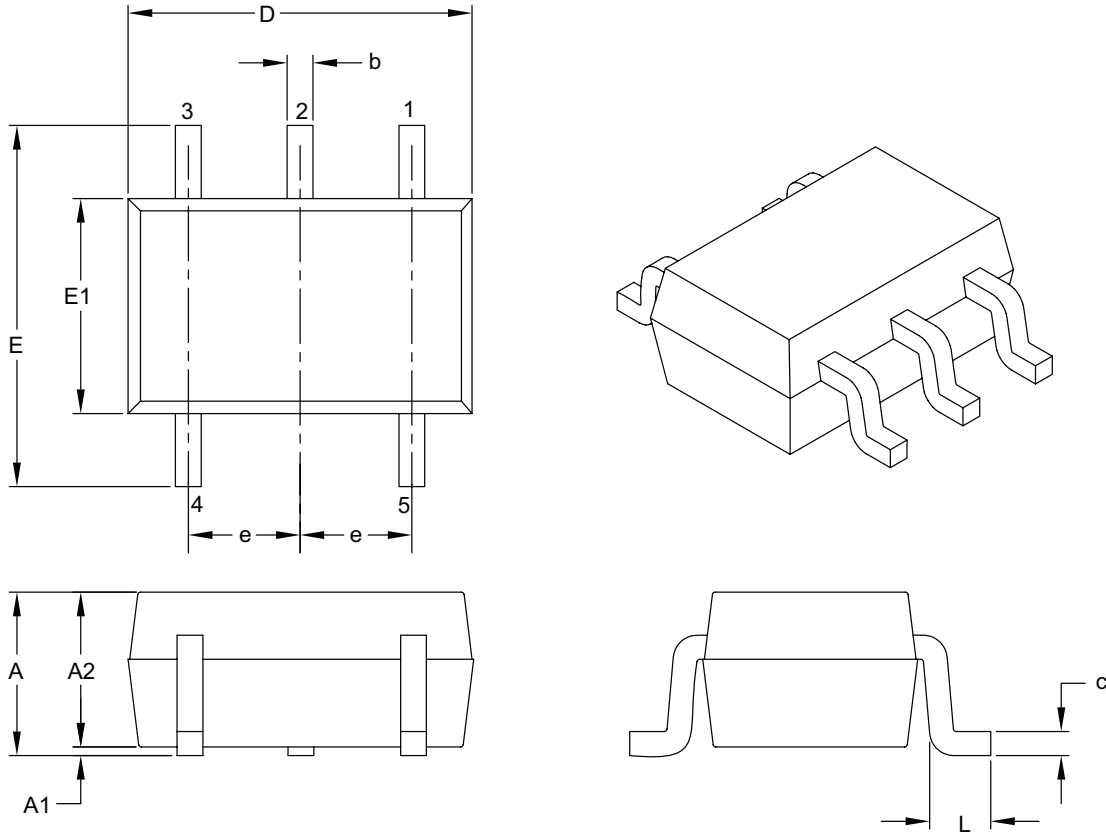

Dimension Limits	Units	MILLIMETERS		
		MIN	NOM	MAX
Number of Pins	N	5		
Pitch	e	0.65 BSC		
Overall Height	A	0.80	–	1.10
Molded Package Thickness	A2	0.80	–	1.00
Standoff	A1	0.00	–	0.10
Overall Width	E	1.80	2.10	2.40
Molded Package Width	E1	1.15	1.25	1.35
Overall Length	D	1.80	2.00	2.25
Foot Length	L	0.10	0.20	0.46
Lead Thickness	c	0.08	–	0.26
Lead Width	b	0.15	–	0.40

Notes:

- Dimensions D and E1 do not include mold flash or protrusions. Mold flash or protrusions shall not exceed 0.127 mm per side.
- Dimensioning and tolerancing per ASME Y14.5M.
BSC: Basic Dimension. Theoretically exact value shown without tolerances.

Microchip Technology Drawing C04-061B

MCP6566/6R/6U/7/9

5-Lead Plastic Small Outline Transistor (LT) [SC70]

Note: For the most current package drawings, please see the Microchip Packaging Specification located at <http://www.microchip.com/packaging>

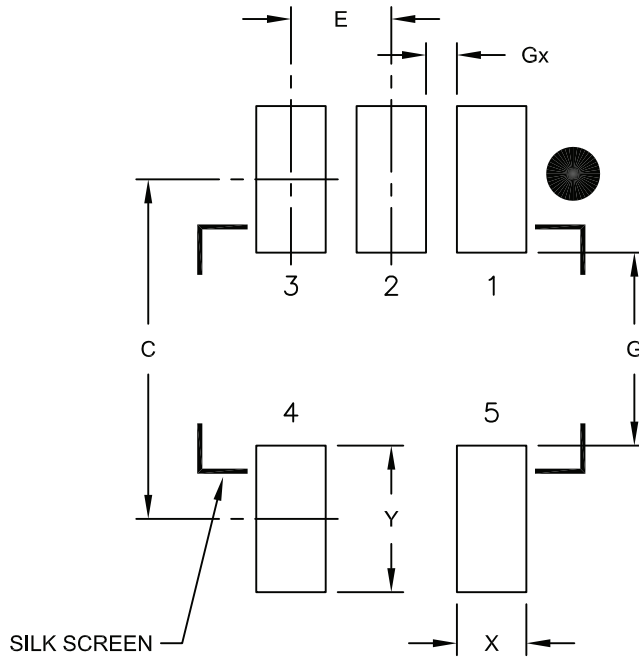

RECOMMENDED LAND PATTERN

Dimension Limits	Units	MILLIMETERS		
		MIN	NOM	MAX
Contact Pitch	E	0.65 BSC		
Contact Pad Spacing	C		2.20	
Contact Pad Width	X			0.45
Contact Pad Length	Y			0.95
Distance Between Pads	G	1.25		
Distance Between Pads	Gx	0.20		

Notes:

1. Dimensioning and tolerancing per ASME Y14.5M

BSC: Basic Dimension. Theoretically exact value shown without tolerances.

Microchip Technology Drawing No. C04-2061A

5-Lead Plastic Small Outline Transistor (OT) [SOT-23]

Note: For the most current package drawings, please see the Microchip Packaging Specification located at <http://www.microchip.com/packaging>

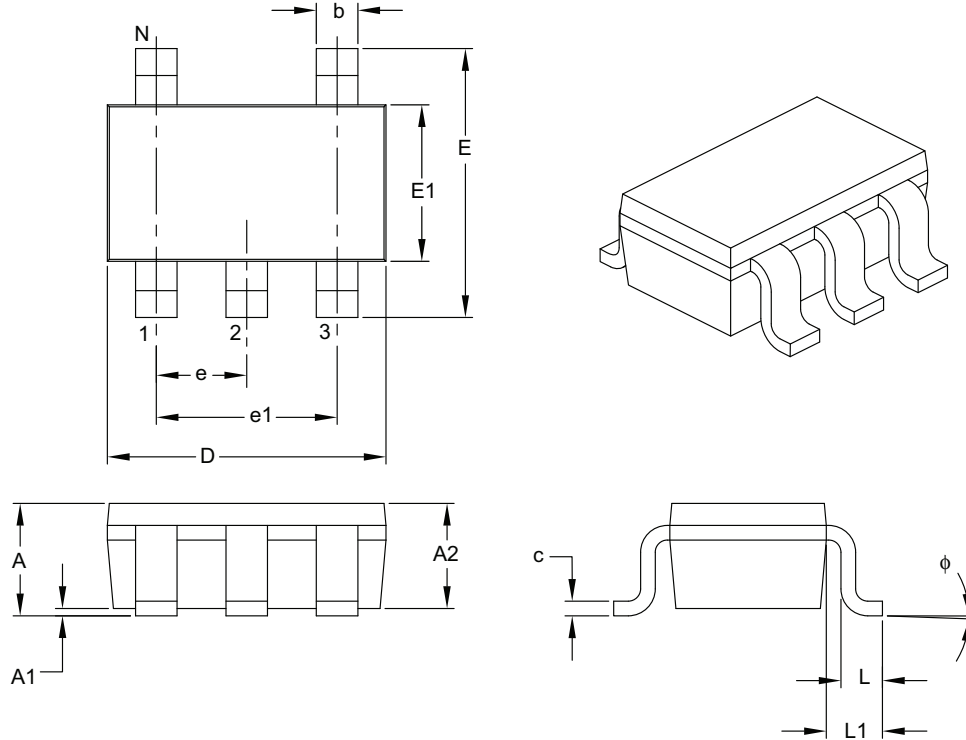

Dimension Limits	Units	MILLIMETERS		
		MIN	NOM	MAX
Number of Pins	N	5		
Lead Pitch	e	0.95 BSC		
Outside Lead Pitch	e1	1.90 BSC		
Overall Height	A	0.90	–	1.45
Molded Package Thickness	A2	0.89	–	1.30
Standoff	A1	0.00	–	0.15
Overall Width	E	2.20	–	3.20
Molded Package Width	E1	1.30	–	1.80
Overall Length	D	2.70	–	3.10
Foot Length	L	0.10	–	0.60
Footprint	L1	0.35	–	0.80
Foot Angle	ϕ	0°	–	30°
Lead Thickness	c	0.08	–	0.26
Lead Width	b	0.20	–	0.51

Notes:

- Dimensions D and E1 do not include mold flash or protrusions. Mold flash or protrusions shall not exceed 0.127 mm per side.
- Dimensioning and tolerancing per ASME Y14.5M.

BSC: Basic Dimension. Theoretically exact value shown without tolerances.

Microchip Technology Drawing C04-091B

MCP6566/6R/6U/7/9

5-Lead Plastic Small Outline Transistor (OT) [SOT-23]

Note: For the most current package drawings, please see the Microchip Packaging Specification located at <http://www.microchip.com/packaging>

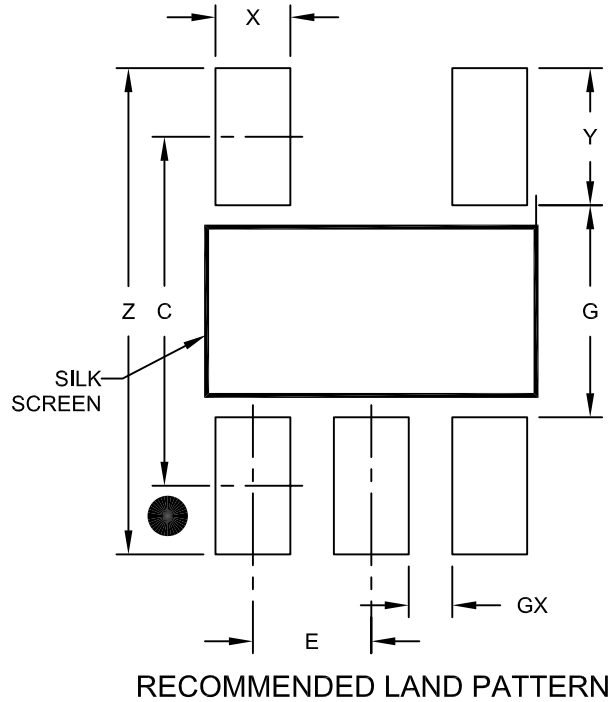

Dimension Limits	Units	MILLIMETERS		
		MIN	NOM	MAX
Contact Pitch	E	0.95 BSC		
Contact Pad Spacing	C		2.80	
Contact Pad Width (X5)	X			0.60
Contact Pad Length (X5)	Y			1.10
Distance Between Pads	G	1.70		
Distance Between Pads	GX	0.35		
Overall Width	Z			3.90

Notes:

1. Dimensioning and tolerancing per ASME Y14.5M

BSC: Basic Dimension. Theoretically exact value shown without tolerances.

Microchip Technology Drawing No. C04-2091A

8-Lead Plastic Micro Small Outline Package (MS) [MSOP]

Note: For the most current package drawings, please see the Microchip Packaging Specification located at <http://www.microchip.com/packaging>

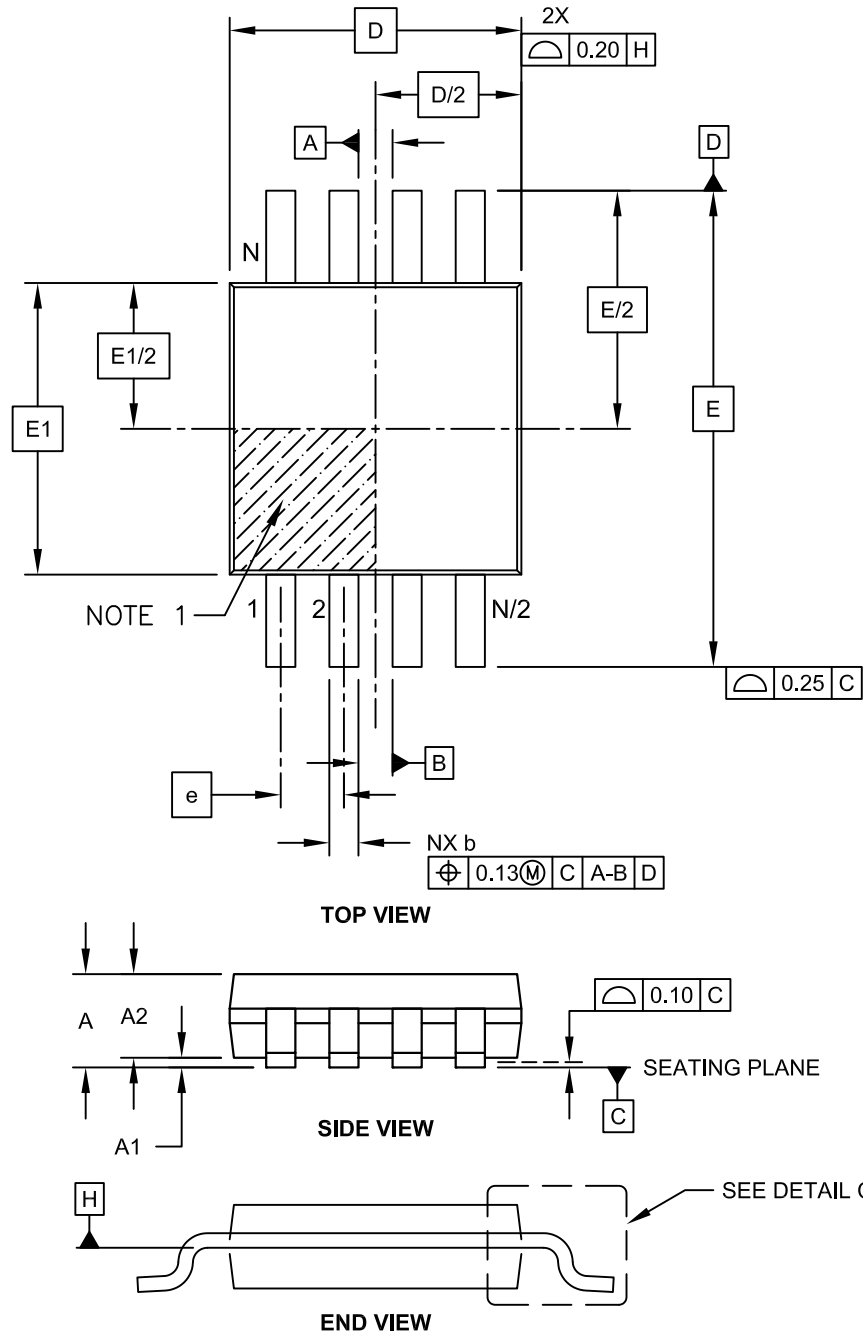

Microchip Technology Drawing C04-111C Sheet 1 of 2

MCP6566/6R/6U/7/9

8-Lead Plastic Micro Small Outline Package (MS) [MSOP]

Note: For the most current package drawings, please see the Microchip Packaging Specification located at <http://www.microchip.com/packaging>

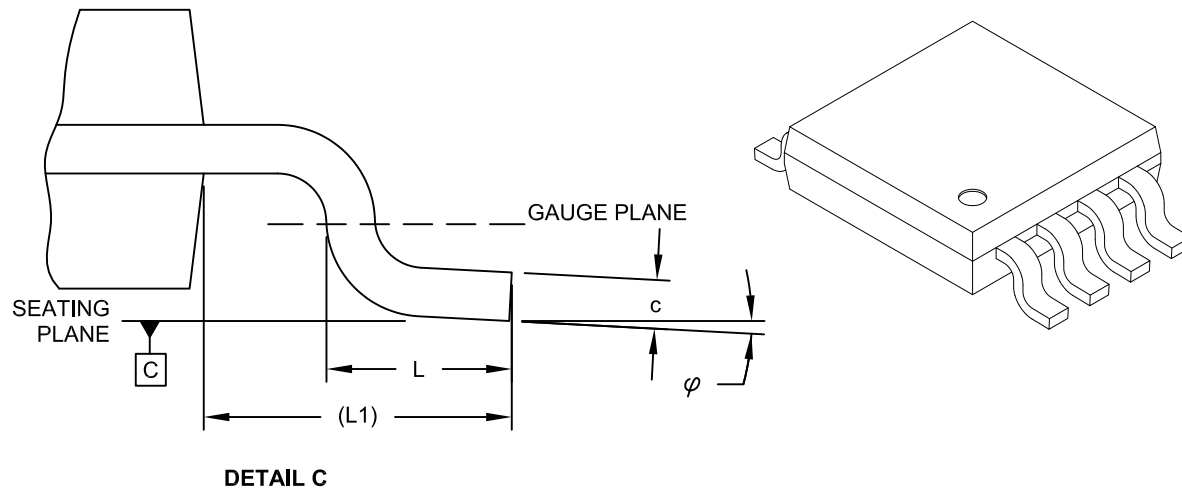

Dimension Limits	Units	MILLIMETERS		
		MIN	NOM	MAX
Number of Pins	N		8	
Pitch	e	0.65 BSC		
Overall Height	A	-	-	1.10
Molded Package Thickness	A2	0.75	0.85	0.95
Standoff	A1	0.00	-	0.15
Overall Width	E	4.90 BSC		
Molded Package Width	E1	3.00 BSC		
Overall Length	D	3.00 BSC		
Foot Length	L	0.40	0.60	0.80
Footprint	L1	0.95 REF		
Foot Angle	φ	0°	-	8°
Lead Thickness	c	0.08	-	0.23
Lead Width	b	0.22	-	0.40

Notes:

- Pin 1 visual index feature may vary, but must be located within the hatched area.
- Dimensions D and E1 do not include mold flash or protrusions. Mold flash or protrusions shall not exceed 0.15mm per side.
- Dimensioning and tolerancing per ASME Y14.5M.

BSC: Basic Dimension. Theoretically exact value shown without tolerances.

REF: Reference Dimension, usually without tolerance, for information purposes only.

Microchip Technology Drawing C04-111C Sheet 2 of 2

8-Lead Plastic Micro Small Outline Package (MS) [MSOP]

Note: For the most current package drawings, please see the Microchip Packaging Specification located at <http://www.microchip.com/packaging>

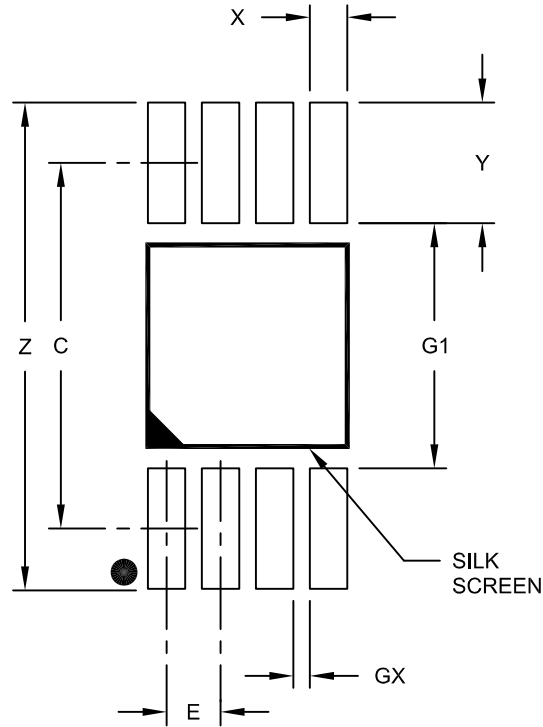

RECOMMENDED LAND PATTERN

Dimension Limits	Units	MILLIMETERS		
		MIN	NOM	MAX
Contact Pitch	E	0.65 BSC		
Contact Pad Spacing	C		4.40	
Overall Width	Z			5.85
Contact Pad Width (X8)	X1			0.45
Contact Pad Length (X8)	Y1			1.45
Distance Between Pads	G1	2.95		
Distance Between Pads	GX	0.20		

Notes:

1. Dimensioning and tolerancing per ASME Y14.5M

BSC: Basic Dimension. Theoretically exact value shown without tolerances.

Microchip Technology Drawing No. C04-2111A

MCP6566/6R/6U/7/9

8-Lead Plastic Small Outline (SN) - Narrow, 3.90 mm Body [SOIC]

Note: For the most current package drawings, please see the Microchip Packaging Specification located at <http://www.microchip.com/packaging>

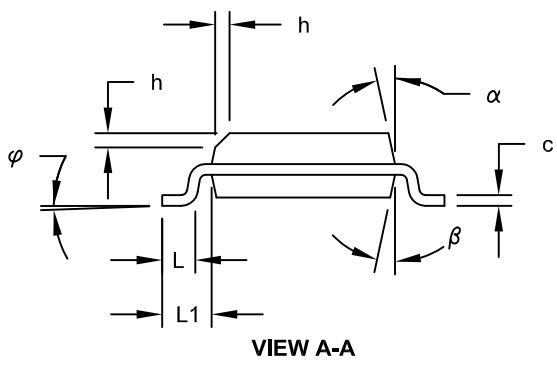
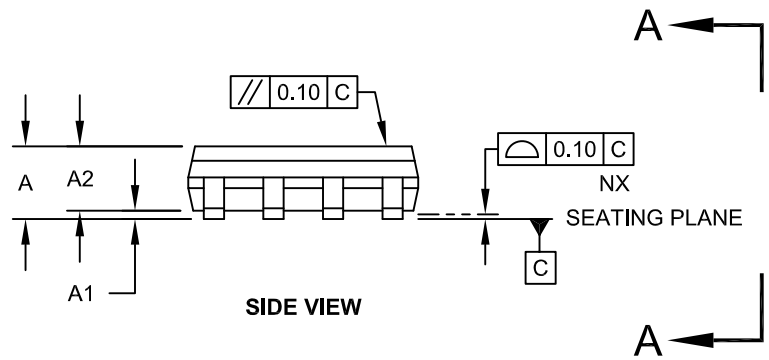
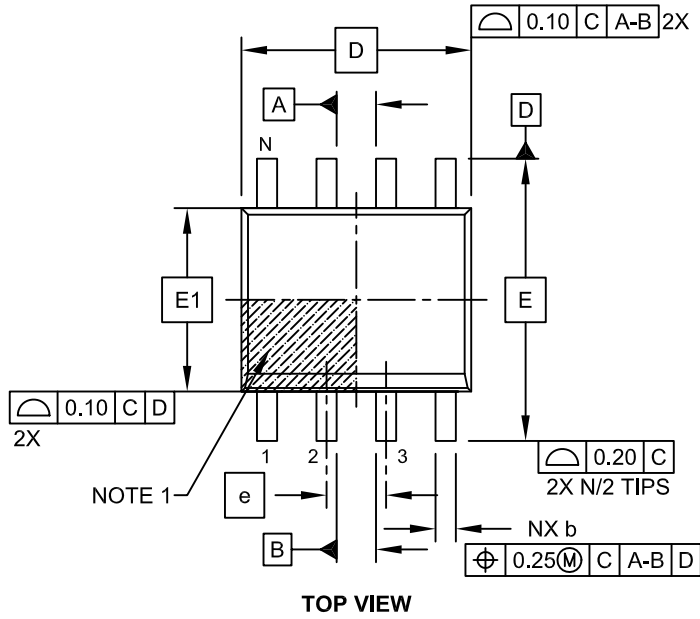

Microchip Technology Drawing No. C04-057C Sheet 1 of 2

MCP6566/6R/6U/7/9

8-Lead Plastic Small Outline (SN) - Narrow, 3.90 mm Body [SOIC]

Note: For the most current package drawings, please see the Microchip Packaging Specification located at <http://www.microchip.com/packaging>

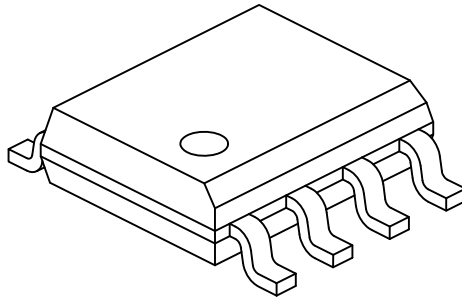

Dimension Limits	Units	MILLIMETERS		
		MIN	NOM	MAX
Number of Pins	N	8		
Pitch	e	1.27 BSC		
Overall Height	A	-	-	1.75
Molded Package Thickness	A2	1.25	-	-
Standoff §	A1	0.10	-	0.25
Overall Width	E	6.00 BSC		
Molded Package Width	E1	3.90 BSC		
Overall Length	D	4.90 BSC		
Chamfer (Optional)	h	0.25	-	0.50
Foot Length	L	0.40	-	1.27
Footprint	L1	1.04 REF		
Foot Angle	φ	0°	-	8°
Lead Thickness	c	0.17	-	0.25
Lead Width	b	0.31	-	0.51
Mold Draft Angle Top	α	5°	-	15°
Mold Draft Angle Bottom	β	5°	-	15°

Notes:

1. Pin 1 visual index feature may vary, but must be located within the hatched area.
2. § Significant Characteristic
3. Dimensions D and E1 do not include mold flash or protrusions. Mold flash or protrusions shall not exceed 0.15mm per side.
4. Dimensioning and tolerancing per ASME Y14.5M

BSC: Basic Dimension. Theoretically exact value shown without tolerances.

REF: Reference Dimension, usually without tolerance, for information purposes only.

Microchip Technology Drawing No. C04-057C Sheet 2 of 2

MCP6566/6R/6U/7/9

8-Lead Plastic Small Outline (SN) – Narrow, 3.90 mm Body [SOIC]

Note: For the most current package drawings, please see the Microchip Packaging Specification located at <http://www.microchip.com/packaging>

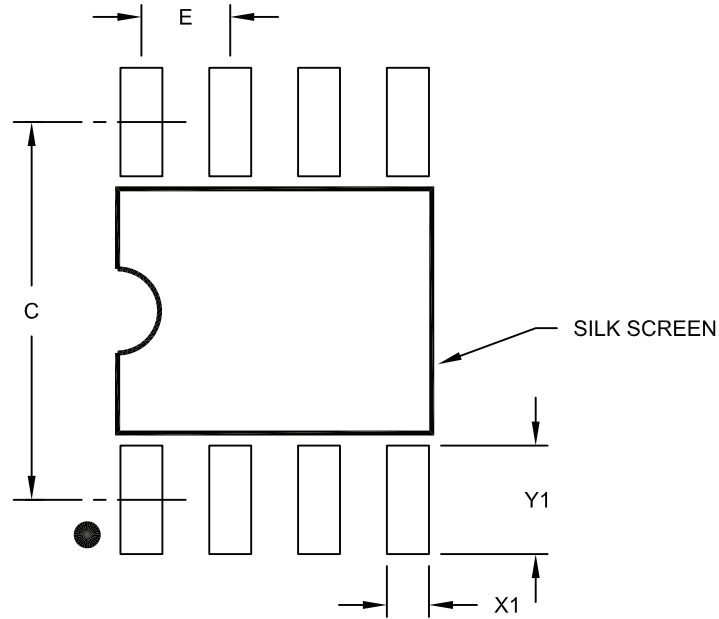

RECOMMENDED LAND PATTERN

Dimension Limits	Units	MILLIMETERS		
		MIN	NOM	MAX
Contact Pitch	E	1.27 BSC		
Contact Pad Spacing	C		5.40	
Contact Pad Width (X8)	X1			0.60
Contact Pad Length (X8)	Y1			1.55

Notes:

1. Dimensioning and tolerancing per ASME Y14.5M

BSC: Basic Dimension. Theoretically exact value shown without tolerances.

Microchip Technology Drawing No. C04-2057A

MCP6566/6R/6U/7/9

14-Lead Plastic Small Outline (SL) - Narrow, 3.90 mm Body [SOIC]

Note: For the most current package drawings, please see the Microchip Packaging Specification located at <http://www.microchip.com/packaging>

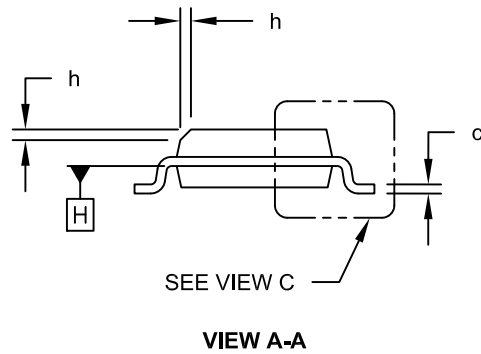
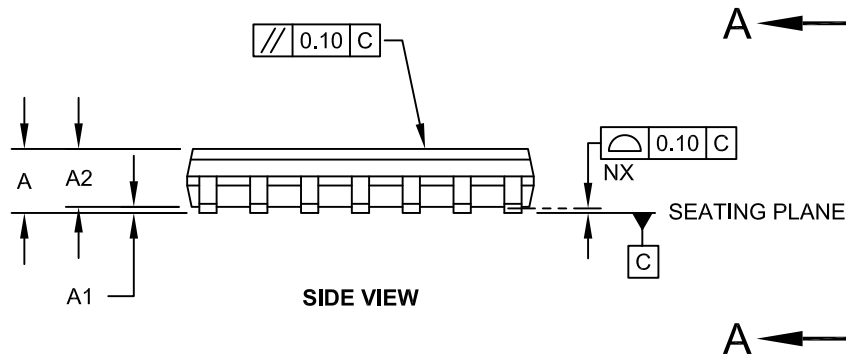
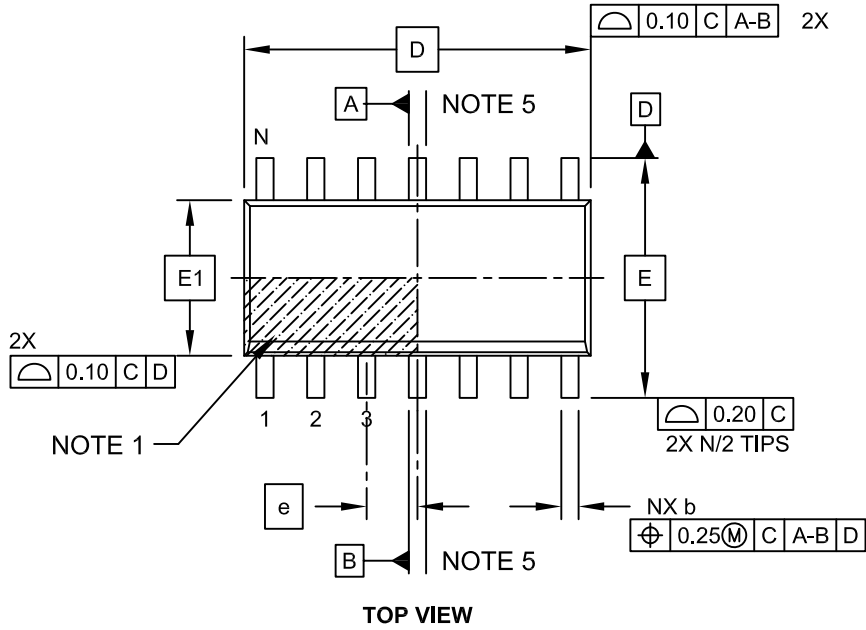

Microchip Technology Drawing No. C04-065C Sheet 1 of 2

MCP6566/6R/6U/7/9

14-Lead Plastic Small Outline (SL) - Narrow, 3.90 mm Body [SOIC]

Note: For the most current package drawings, please see the Microchip Packaging Specification located at <http://www.microchip.com/packaging>

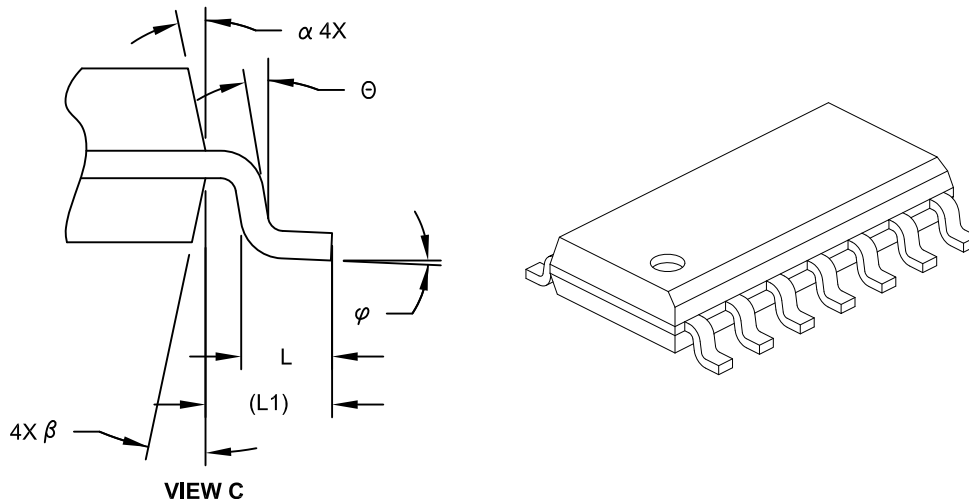

Dimension Limits	Units	MILLIMETERS		
		MIN	NOM	MAX
Number of Pins	N	14		
Pitch	e	1.27 BSC		
Overall Height	A	-	-	1.75
Molded Package Thickness	A2	1.25	-	-
Standoff §	A1	0.10	-	0.25
Overall Width	E	6.00 BSC		
Molded Package Width	E1	3.90 BSC		
Overall Length	D	8.65 BSC		
Chamfer (Optional)	h	0.25	-	0.50
Foot Length	L	0.40	-	1.27
Footprint	L1	1.04 REF		
Lead Angle	Θ	0°	-	-
Foot Angle	φ	0°	-	8°
Lead Thickness	c	0.10	-	0.25
Lead Width	b	0.31	-	0.51
Mold Draft Angle Top	α	5°	-	15°
Mold Draft Angle Bottom	β	5°	-	15°

Notes:

- Pin 1 visual index feature may vary, but must be located within the hatched area.
- § Significant Characteristic
- Dimension D does not include mold flash, protrusions or gate burrs, which shall not exceed 0.15 mm per end. Dimension E1 does not include interlead flash or protrusion, which shall not exceed 0.25 mm per side.
- Dimensioning and tolerancing per ASME Y14.5M
 BSC: Basic Dimension. Theoretically exact value shown without tolerances.
 REF: Reference Dimension, usually without tolerance, for information purposes only.
- Datums A & B to be determined at Datum H.

Microchip Technology Drawing No. C04-065C Sheet 2 of 2

MCP6566/6R/6U/7/9

14-Lead Plastic Small Outline (SL) - Narrow, 3.90 mm Body [SOIC]

Note: For the most current package drawings, please see the Microchip Packaging Specification located at <http://www.microchip.com/packaging>

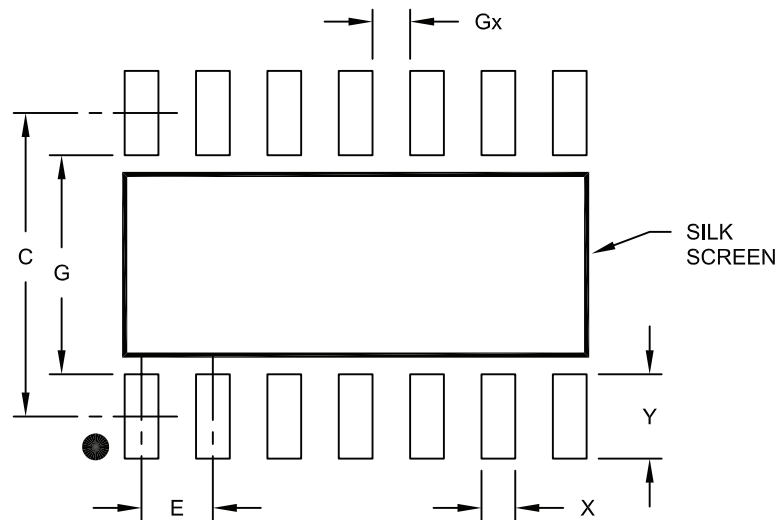

RECOMMENDED LAND PATTERN

Dimension Limits	Units	MILLIMETERS		
		MIN	NOM	MAX
Contact Pitch	E	1.27 BSC		
Contact Pad Spacing	C		5.40	
Contact Pad Width	X			0.60
Contact Pad Length	Y			1.50
Distance Between Pads	Gx	0.67		
Distance Between Pads	G	3.90		

Notes:

1. Dimensioning and tolerancing per ASME Y14.5M

BSC: Basic Dimension. Theoretically exact value shown without tolerances.

Microchip Technology Drawing No. C04-2065A

MCP6566/6R/6U/7/9

14-Lead Plastic Thin Shrink Small Outline (ST) - 4.4 mm Body [TSSOP]

Note: For the most current package drawings, please see the Microchip Packaging Specification located at <http://www.microchip.com/packaging>

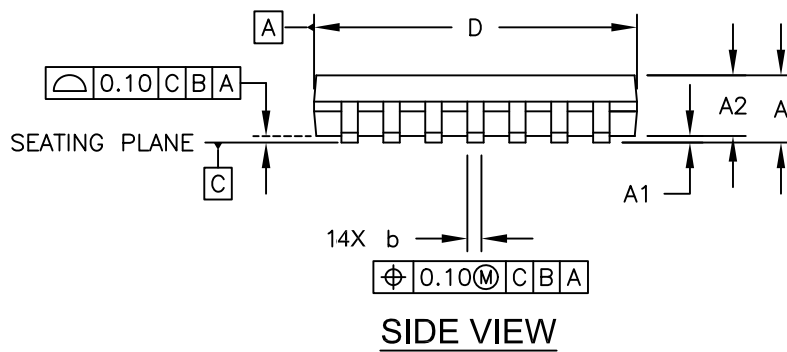
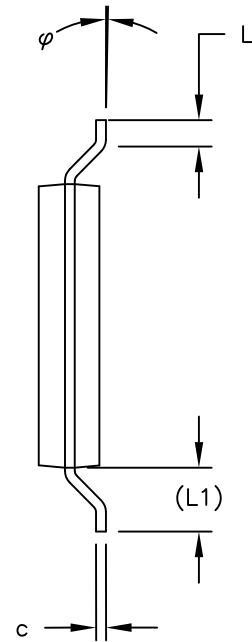
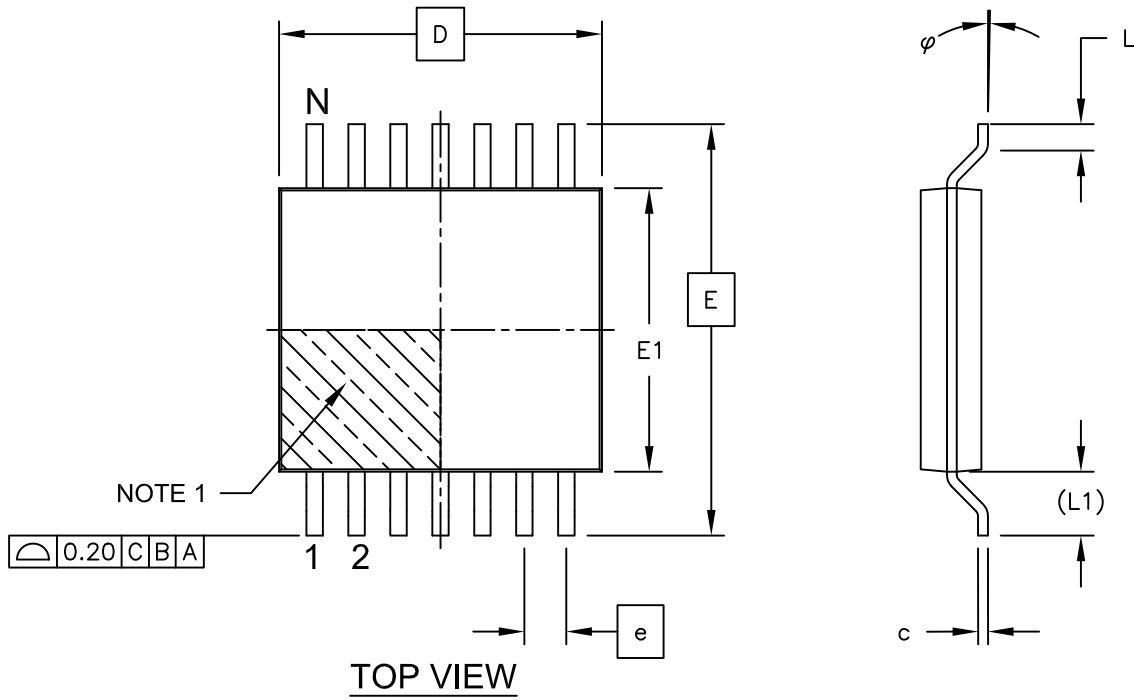

14-Lead Plastic Thin Shrink Small Outline (ST) - 4.4 mm Body [TSSOP]

Note: For the most current package drawings, please see the Microchip Packaging Specification located at <http://www.microchip.com/packaging>

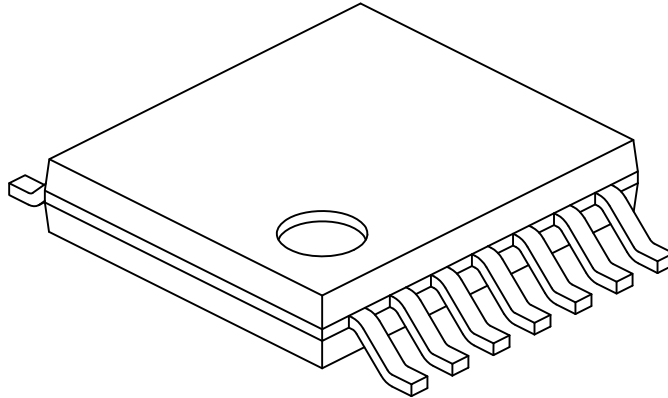

Dimension Limits	Units	MILLIMETERS		
		MIN	NOM	MAX
Number of Pins	N	14		
Pitch	e	0.65 BSC		
Overall Height	A	-	-	1.20
Molded Package Thickness	A2	0.80	1.00	1.05
Standoff	A1	0.05	-	0.15
Overall Width	E	6.40 BSC		
Molded Package Width	E1	4.30	4.40	4.50
Molded Package Length	D	4.90	5.00	5.10
Foot Length	L	0.45	0.60	0.75
Footprint	(L1)	1.00 REF		
Foot Angle	φ	0°	-	8°
Lead Thickness	c	0.09	-	0.20
Lead Width	b	0.19	-	0.30

Notes:

1. Pin 1 visual index feature may vary, but must be located within the hatched area.
2. Dimensions D and E1 do not include mold flash or protrusions. Mold flash or protrusions shall not exceed 0.15mm per side.
3. Dimensioning and tolerancing per ASME Y14.5M

BSC: Basic Dimension. Theoretically exact value shown without tolerances.

REF: Reference Dimension, usually without tolerance, for information purposes only.

Microchip Technology Drawing No. C04-087C Sheet 2 of 2

MCP6566/6R/6U/7/9

14-Lead Plastic Thin Shrink Small Outline (ST) - 4.4 mm Body [TSSOP]

Note: For the most current package drawings, please see the Microchip Packaging Specification located at <http://www.microchip.com/packaging>

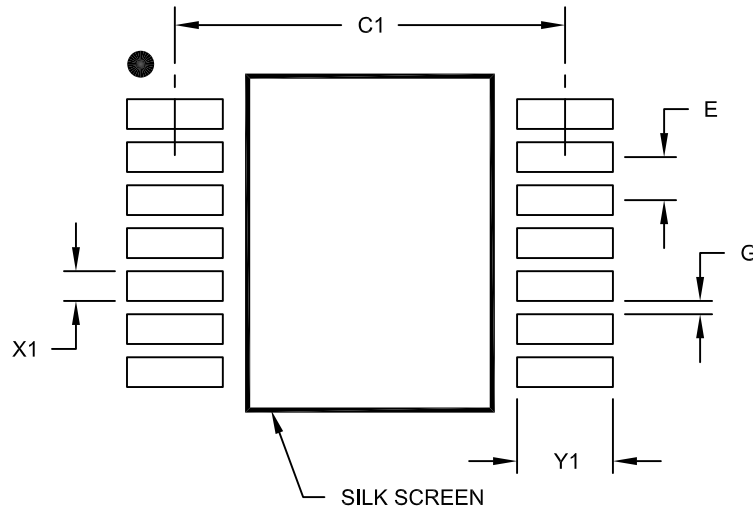

RECOMMENDED LAND PATTERN

Dimension Limits	Units	MILLIMETERS		
		MIN	NOM	MAX
Contact Pitch	E		0.65 BSC	
Contact Pad Spacing	C1		5.90	
Contact Pad Width (X14)	X1			0.45
Contact Pad Length (X14)	Y1			1.45
Distance Between Pads	G	0.20		

Notes:

1. Dimensioning and tolerancing per ASME Y14.5M

BSC: Basic Dimension. Theoretically exact value shown without tolerances.

Microchip Technology Drawing No. C04-2087A

APPENDIX A: REVISION HISTORY

Revision E (November 2014)

The following is the list of modifications:

1. Added SPICE Macro Model in the Related Device features section.
2. Updated [Temperature Specifications](#) table.
3. Corrected pin table in [Section 3.0, Pin Descriptions](#).
4. Added new [Section 5.4, SPICE Macro Model](#).

Revision D (February 2013)

The following is the list of modifications:

1. Added the Analog Input (V_{IN}) parameter in [Section 1.0 "Electrical Characteristics"](#).

Revision C (February 2011)

The following is the list of modifications:

1. Replaced the MCP5468 package name with the correct MCP6567 package name on page 1 and in [Table 3-1](#).

Revision B (August 2009)

The following is the list of modifications:

1. Added MCP6566U throughout the document.
2. Updated package outline drawings.

Revision A (March 2009)

- Original Release of this Document.

MCP6566/6R/6U/7/9

NOTES:

PRODUCT IDENTIFICATION SYSTEM

To order or obtain information, e.g., on pricing or delivery, refer to the factory or the listed sales office.

<u>PART NO.</u>	-	<u>X</u>	<u>/XX</u>
Device		Temperature Range	Package
Device:			MCP6566T: Single Comparator (Tape and Reel) (SC70, SOT-23) MCP6566RT: Single Comparator (Tape and Reel) (SOT-23 only) MCP6566UT: Single Comparator (Tape and Reel) (SOT-23 only) MCP6567: Dual Comparator MCP6567T: Dual Comparator (Tape and Reel) MCP6569: Quad Comparator MCP6569T: Quad Comparator (Tape and Reel)
Temperature Range:		E = -40°C to +125°C	
Package:			LT = Plastic Small Outline Transistor (SC70), 5-lead OT = Plastic Small Outline Transistor (SOT-23), 5-lead MS = Plastic Micro Small Outline Transistor, 8-lead SN = Plastic Small Outline Transistor, 8-lead ST = Plastic Thin Shrink Small Outline Transistor, 14-lead SL = Plastic Small Outline Transistor, 14-lead
Examples:			
a)	MCP6566T-E/LT:	Tape and Reel, Extended Temperature, 5LD SC70 package.	
b)	MCP6566T-E/OT:	Tape and Reel, Extended Temperature, 5LD SOT-23 package.	
a)	MCP6566RT-E/OT:	Tape and Reel, Extended Temperature, 5LD SOT-23 package.	
a)	MCP6566UT-E/OT:	Tape and Reel, Extended Temperature, 5LD SOT-23 package.	
a)	MCP6567-E/MS:	Extended Temperature 8LD MSOP package.	
b)	MCP6567-E/SN:	Extended Temperature 8LD SOIC package.	
a)	MCP6569T-E/SL:	Tape and Reel, Extended Temperature 14LD SOIC package.	
b)	MCP6569T-E/ST:	Tape and Reel, Extended Temperature 14LD TSSOP package.	

MCP6566/6R/6U/7/9

NOTES:

Note the following details of the code protection feature on Microchip devices:

- Microchip products meet the specification contained in their particular Microchip Data Sheet.
- Microchip believes that its family of products is one of the most secure families of its kind on the market today, when used in the intended manner and under normal conditions.
- There are dishonest and possibly illegal methods used to breach the code protection feature. All of these methods, to our knowledge, require using the Microchip products in a manner outside the operating specifications contained in Microchip's Data Sheets. Most likely, the person doing so is engaged in theft of intellectual property.
- Microchip is willing to work with the customer who is concerned about the integrity of their code.
- Neither Microchip nor any other semiconductor manufacturer can guarantee the security of their code. Code protection does not mean that we are guaranteeing the product as “unbreakable.”

Code protection is constantly evolving. We at Microchip are committed to continuously improving the code protection features of our products. Attempts to break Microchip's code protection feature may be a violation of the Digital Millennium Copyright Act. If such acts allow unauthorized access to your software or other copyrighted work, you may have a right to sue for relief under that Act.

Information contained in this publication regarding device applications and the like is provided only for your convenience and may be superseded by updates. It is your responsibility to ensure that your application meets with your specifications. MICROCHIP MAKES NO REPRESENTATIONS OR WARRANTIES OF ANY KIND WHETHER EXPRESS OR IMPLIED, WRITTEN OR ORAL, STATUTORY OR OTHERWISE, RELATED TO THE INFORMATION, INCLUDING BUT NOT LIMITED TO ITS CONDITION, QUALITY, PERFORMANCE, MERCHANTABILITY OR FITNESS FOR PURPOSE. Microchip disclaims all liability arising from this information and its use. Use of Microchip devices in life support and/or safety applications is entirely at the buyer's risk, and the buyer agrees to defend, indemnify and hold harmless Microchip from any and all damages, claims, suits, or expenses resulting from such use. No licenses are conveyed, implicitly or otherwise, under any Microchip intellectual property rights.

Trademarks

The Microchip name and logo, the Microchip logo, dsPIC, FlashFlex, flexPWR, JukeBlox, KEELOQ, KEELOQ logo, Klear, LANCheck, MediaLB, MOST, MOST logo, MPLAB, OptoLyzer, PIC, PICSTART, PIC³² logo, RightTouch, SpyNIC, SST, SST Logo, SuperFlash and UNI/O are registered trademarks of Microchip Technology Incorporated in the U.S.A. and other countries.

The Embedded Control Solutions Company and mTouch are registered trademarks of Microchip Technology Incorporated in the U.S.A.

Analog-for-the-Digital Age, BodyCom, chipKIT, chipKIT logo, CodeGuard, dsPICDEM, dsPICDEM.net, ECAN, In-Circuit Serial Programming, ICSP, Inter-Chip Connectivity, KlearNet, KlearNet logo, MiWi, MPASM, MPF, MPLAB Certified logo, MPLIB, MPLINK, MultiTRAK, NetDetach, Omniscient Code Generation, PICDEM, PICDEM.net, PICkit, PICtail, RightTouch logo, REAL ICE, SQI, Serial Quad I/O, Total Endurance, TSHARC, USBCheck, VariSense, ViewSpan, WiperLock, Wireless DNA, and ZENA are trademarks of Microchip Technology Incorporated in the U.S.A. and other countries.

SQTP is a service mark of Microchip Technology Incorporated in the U.S.A.

Silicon Storage Technology is a registered trademark of Microchip Technology Inc. in other countries.

GestIC is a registered trademarks of Microchip Technology Germany II GmbH & Co. KG, a subsidiary of Microchip Technology Inc., in other countries.

All other trademarks mentioned herein are property of their respective companies.

© 2009-2014, Microchip Technology Incorporated, Printed in the U.S.A., All Rights Reserved.

ISBN: 978-1-63276-677-9

QUALITY MANAGEMENT SYSTEM
CERTIFIED BY DNV
== ISO/TS 16949 ==

Microchip received ISO/TS-16949:2009 certification for its worldwide headquarters, design and wafer fabrication facilities in Chandler and Tempe, Arizona; Gresham, Oregon and design centers in California and India. The Company's quality system processes and procedures are for its PIC® MCUs and dsPIC® DSCs, KEELOQ® code hopping devices, Serial EEPROMs, microperipherals, nonvolatile memory and analog products. In addition, Microchip's quality system for the design and manufacture of development systems is ISO 9001:2000 certified.



MICROCHIP

Worldwide Sales and Service

AMERICAS

Corporate Office
2355 West Chandler Blvd.
Chandler, AZ 85224-6199
Tel: 480-792-7200
Fax: 480-792-7277
Technical Support:
<http://www.microchip.com/support>
Web Address:
www.microchip.com

Atlanta
Duluth, GA
Tel: 678-957-9614
Fax: 678-957-1455

Austin, TX
Tel: 512-257-3370

Boston
Westborough, MA
Tel: 774-760-0087
Fax: 774-760-0088

Chicago
Itasca, IL
Tel: 630-285-0071
Fax: 630-285-0075

Cleveland
Independence, OH
Tel: 216-447-0464
Fax: 216-447-0643

Dallas
Addison, TX
Tel: 972-818-7423
Fax: 972-818-2924

Detroit
Novi, MI
Tel: 248-848-4000

Houston, TX
Tel: 281-894-5983

Indianapolis
Noblesville, IN
Tel: 317-773-8323
Fax: 317-773-5453

Los Angeles
Mission Viejo, CA
Tel: 949-462-9523
Fax: 949-462-9608

New York, NY
Tel: 631-435-6000

San Jose, CA
Tel: 408-735-9110

Canada - Toronto
Tel: 905-673-0699
Fax: 905-673-6509

ASIA/PACIFIC

Asia Pacific Office
Suites 3707-14, 37th Floor
Tower 6, The Gateway
Harbour City, Kowloon
Hong Kong
Tel: 852-2943-5100
Fax: 852-2401-3431

Australia - Sydney
Tel: 61-2-9868-6733
Fax: 61-2-9868-6755

China - Beijing
Tel: 86-10-8569-7000
Fax: 86-10-8528-2104

China - Chengdu
Tel: 86-28-8665-5511
Fax: 86-28-8665-7889

China - Chongqing
Tel: 86-23-8980-9588
Fax: 86-23-8980-9500

China - Hangzhou
Tel: 86-571-8792-8115
Fax: 86-571-8792-8116

China - Hong Kong SAR
Tel: 852-2943-5100
Fax: 852-2401-3431

China - Nanjing
Tel: 86-25-8473-2460
Fax: 86-25-8473-2470

China - Qingdao
Tel: 86-532-8502-7355
Fax: 86-532-8502-7205

China - Shanghai
Tel: 86-21-5407-5533
Fax: 86-21-5407-5066

China - Shenyang
Tel: 86-24-2334-2829
Fax: 86-24-2334-2393

China - Shenzhen
Tel: 86-755-8864-2200
Fax: 86-755-8203-1760

China - Wuhan
Tel: 86-27-5980-5300
Fax: 86-27-5980-5118

China - Xian
Tel: 86-29-8833-7252
Fax: 86-29-8833-7256

China - Xiamen
Tel: 86-592-2388138
Fax: 86-592-2388130

China - Zhuhai
Tel: 86-756-3210040
Fax: 86-756-3210049

ASIA/PACIFIC

India - Bangalore
Tel: 91-80-3090-4444
Fax: 91-80-3090-4123

India - New Delhi
Tel: 91-11-4160-8631
Fax: 91-11-4160-8632

India - Pune
Tel: 91-20-3019-1500

Japan - Osaka
Tel: 81-6-6152-7160
Fax: 81-6-6152-9310

Japan - Tokyo
Tel: 81-3-6880-3770
Fax: 81-3-6880-3771

Korea - Daegu
Tel: 82-53-744-4301
Fax: 82-53-744-4302

Korea - Seoul
Tel: 82-2-554-7200
Fax: 82-2-558-5932 or
82-2-558-5934

Malaysia - Kuala Lumpur
Tel: 60-3-6201-9857
Fax: 60-3-6201-9859

Malaysia - Penang
Tel: 60-4-227-8870
Fax: 60-4-227-4068

Philippines - Manila
Tel: 63-2-634-9065
Fax: 63-2-634-9069

Singapore
Tel: 65-6334-8870
Fax: 65-6334-8850

Taiwan - Hsin Chu
Tel: 886-3-5778-366
Fax: 886-3-5770-955

Taiwan - Kaohsiung
Tel: 886-7-213-7830

Taiwan - Taipei
Tel: 886-2-2508-8600
Fax: 886-2-2508-0102

Thailand - Bangkok
Tel: 66-2-694-1351
Fax: 66-2-694-1350

EUROPE

Austria - Wels
Tel: 43-7242-2244-39
Fax: 43-7242-2244-393

Denmark - Copenhagen
Tel: 45-4450-2828
Fax: 45-4485-2829

France - Paris
Tel: 33-1-69-53-63-20
Fax: 33-1-69-30-90-79

Germany - Dusseldorf
Tel: 49-2129-3766400

Germany - Munich
Tel: 49-89-627-144-0
Fax: 49-89-627-144-44

Germany - Pforzheim
Tel: 49-7231-424750

Italy - Milan
Tel: 39-0331-742611
Fax: 39-0331-466781

Italy - Venice
Tel: 39-049-7625286

Netherlands - Drunen
Tel: 31-416-690399
Fax: 31-416-690340

Poland - Warsaw
Tel: 48-22-3325737

Spain - Madrid
Tel: 34-91-708-08-90
Fax: 34-91-708-08-91

Sweden - Stockholm
Tel: 46-8-5090-4654

UK - Wokingham
Tel: 44-118-921-5800
Fax: 44-118-921-5820

03/25/14

Mouser Electronics

Authorized Distributor

Click to View Pricing, Inventory, Delivery & Lifecycle Information:

[Microchip:](#)

[MCP6566RT-E/OT](#)