

REVISIONS					
REV	ECO	DESCRIPTION	DATE	BY	APPR
A1	-	TECHNICAL DATA SHEET RELEASE	12-MAY-14	KMM	RFC

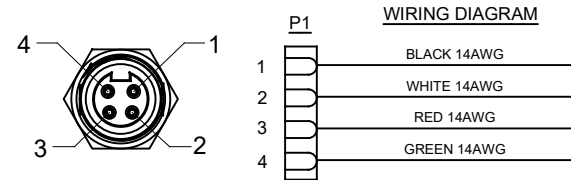
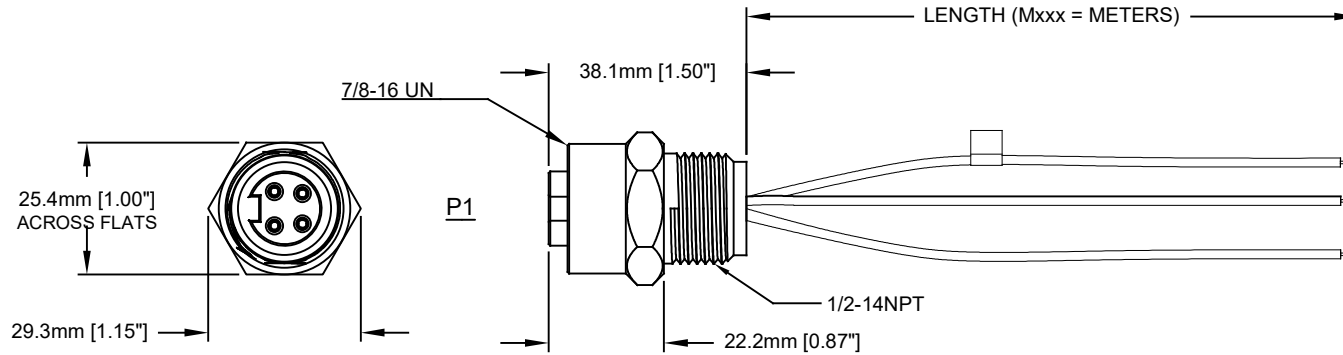

TECHNICAL DATA:

- MATERIALS:**
 HOUSING: MACHINED ALUMINUM, ANODIZED
 INSULATION INSERT: THERMOPLASTIC, UL 94/V-0
 CONTACT: GOLD FLASH PLATING OVER COPPER ALLOY
 CONDUCTOR INSULATION: PVC
 NUMBER OF CONDUCTORS: (4) 14AWG
- ELECTRICAL DATA:**
 CURRENT (MAX): 15A
 VOLTAGE (MAX): 600V AC/DC
 INSULATION RESISTANCE (MIN): 5000M OHMS
 DIELECTRIC TEST VOLTAGE: 2200V
- MECHANICAL DATA:**
 KNOCKOUT HOLE SIZE FOR PANEL MOUNT: 22.2mm [.88"]
 TEMPERATURE RANGE: -40°C TO 90°C
 PROTECTION: IP67 (MATED CONDITION)
 MATING CYCLES: >500
 VIBRATION RESISTANCE PER MIL-STD-202 METHOD 204
 THERMAL SHOCK PER MIL-STD-202 METHOD 207
 48 HOUR SALT SPRAY PER MIL-STD-202 METHOD 101
- RoHS COMPLIANT**
- UL 2237 LISTED ASSEMBLY**
 UL FILE NUMBERS: E339703

Amphenol P/N	ROCKWELL P/N	MOLEX	TURCK
P29037-M*	280-M22F-M*	1R4C00A20A*	RKF44-*.M/NPT
P29037-M.5	280-M22F-M.5	1R4C00A20A005G	RKF44-.5M/NPT
P29037-M1	280-M22F-M1	1R4C00A20A010G	RKF44-1M/NPT
P29037-M2	280-M22F-M2	1R4C00A20A020G	RKF44-2M/NPT
P29037-M3	280-M22F-M3	1R4C00A20A030G	RKF44-3M/NPT

TOLERANCE	
0-2.99 M = +100.0/-25.0mm	0-9.99 FT = +4" / -1"
3-8.99 M = +150.0/-25.0mm	10.00-29.99 FT = +6" / -1"
9-14.99 M = +300.0/-25.0mm	30.00-49.99 FT = +12" / -1"
15-OVER M = +450.0/-25.0mm	50 FT-OVER = +18" / -1"

QUANTITY	PART NUMBER	DESCRIPTION	ITEM
MATERIALS LIST			
<small>UNLESS OTHERWISE SPECIFIED</small> 1) All dimensions are in metric (mm). 2) Tolerances are as follows: 1 PL DEC ±0.30 Fractions ±1/64 2 PL DEC ±0.15 Angles ±1° 3 PL DEC ±0.08 3) Note reference =		Amphenol Sine Systems - www.amphenol-sine.com 44724 Morley Drive Clinton Township, MI 48036	
<small>SIGNATURES</small> DRAWN: KMM CHECKED: MRF ENGINEER: KMM APPROVAL: RFC DATE: 12-MAY-14		M22 PB LITE, 4 PIN, FEMALE RECEPTACLE DROP, 14 AWG, 1/2 - 14NPT	
<small>MATERIAL SPECIFICATIONS:</small> CUSTOMER:		<small>THIS DRAWING IS SUPPLIED FOR INFORMATION ONLY. DESIGN FEATURES, SPECIFICATIONS AND PERFORMANCE DATA SHOWN HEREON ARE THE PROPERTY OF THE AMPHENOL CORPORATION. NO RIGHTS OF REPRODUCTION ARE IMPLIED. ALL DIMENSIONS ARE SUBJECT TO NORMAL MANUFACTURING VARIATIONS.</small>	
<small>PROCESS SPECIFICATIONS:</small> NEXT ASSY:		SIZE: C- SCALE: FULL	DWG NO: P29037-Mxxx SHEET 1 OF 1

TRM: 4/22 PB LITE, 4 PIN, FEMALE REC., 14AWG, 1/2-14NPT dwg no: C-P29037-Mxxx rev: A1 sh: 1 of: 1