

DATA SHEET

HGARAN008A

List of Contents

1	Product Description	製品説明	3
1.1	Overview	概要	3
1.2	Target Applications	ターゲットアプリケーション	3
2	Functional Description	機能説明	4
2.1	Pin Configuration	ピン配置	4
2.2	Pin Description	ピン機能	4
3	Specifications	仕様	5
3.1	Absolute Maximum Ratings	絶対最大定格	5
3.2	Operating Conditions	動作条件	5
3.3	Basic Characteristics	基本特性	6
3.4	Electric Characteristics	電気特性	6
4	Package Information	パッケージ情報	10
4.1	Appearance	外観	10
4.2	Package Outline	外形図	10
4.3	Footprint	フットプリント	11
4.4	Package Marking	捺印	11
4.5	Structure	構造	12
5	Packing Specifications	梱包仕様	13
5.1	Packing Information	梱包情報	13
5.2	Packing Specifications	梱包仕様	14
6	Reliability Test Conditions	信頼性試験条件	16
6.1	Preconditioning for Reliability Test	信頼性試験の前処理	16
6.2	Reliability Test Items	信頼性試験項目	16
7	Precautions When Handling Magnetic Sensor	製品お取り扱い時の注意	17
7.1	Storage Environment	保管環境	17
7.2	Long-term Storage	長期保管	17
7.3	ESD	静電気ESD	17
7.4	External Magnetic Field	外乱磁場	17
	Appendix		
A1	List of Figures	図のリスト	18
A2	List of Tables	表のリスト	18
A3	Revision History	改定履歴	19

1 Product Description 製品説明

1.1 Overview 概要

ALPS Product No.	HGARAN008A
Characteristic	Angle Sensor
Package type	DFN 1.8mm x 1.05mm x t0.65mm
Supply Voltage	max. 5.5V
Operating Magnetic Field	20 ~ 60 mT
Operating Temperature	-40 ~ 105 deg.C
Interface	Analog Output

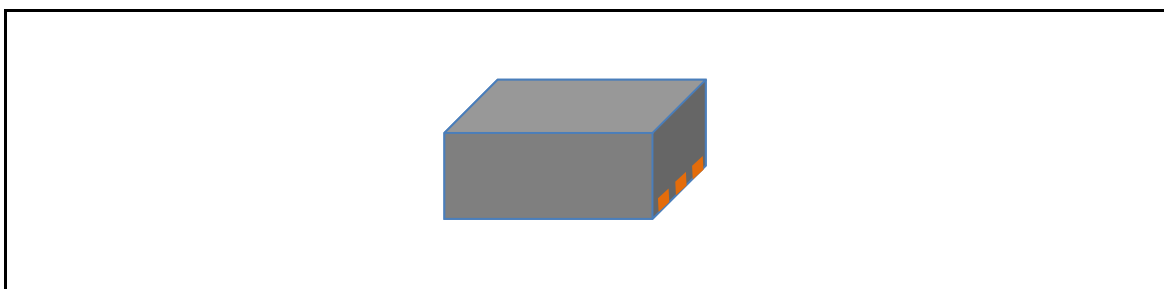

Figure 1-1 Image of HGARAN008A in the DFN Package

1.2 Target Applications ターゲットアプリケーション

Home Appliance
Office Automation
Industrial

2 Functional Description 機能説明

2.1 Pin Configuration ピン配置

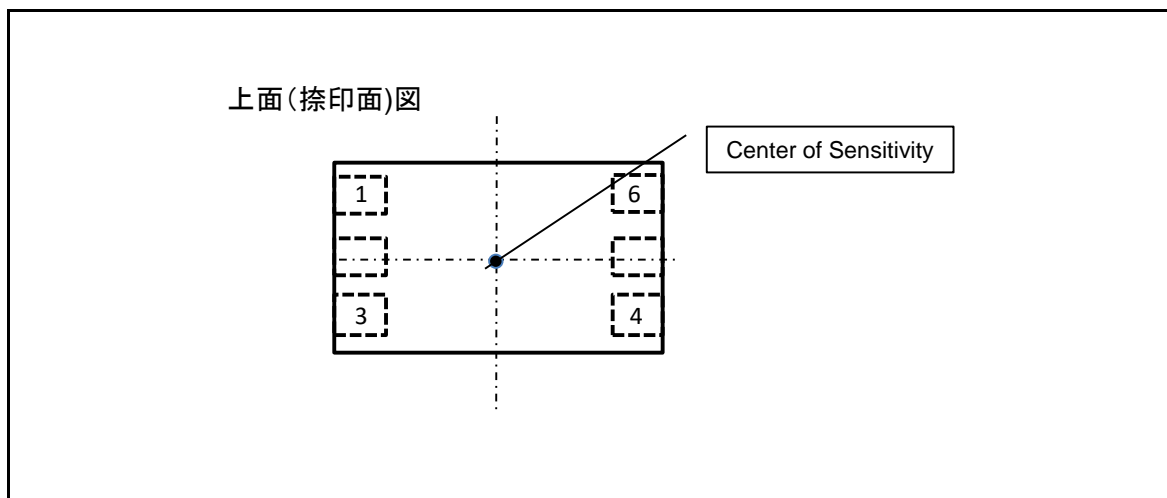

Figure 2-1 Pin Configuration

2.2 Pin Description ピン機能

Table 2-1 Pin Description

Pin No.	Function	Pin No.	Function
1	+Sin out	4	-Sin out
2	+Cos out	5	-Cos out
3	GND	6	VDD

3 Specifications 仕様

3.1 Absolute Maximum Ratings 絶対最大定格

Table 3-1 Absolute Maximum Rating Parameters

Parameter	Symbol	Values			Unit	Note
		Min.	Typ.	Max.		
Supply Voltage	VDD	-	-	5.5	V	
Storage Temperature	Tstg	-40	-	105	deg.C	
Magnetic Field Strength	Hext	-	-	200	mT	at Room Temp.
		-	-	160	kA/m	

[note]

The maximum rating is the value that must not be exceeded it even if it is momentary. There is a possibility of the breakdown and/or destruction when this value is exceeded.

最大定格とは、たとえ瞬間的であっても超えてはならない値であり、この値を超えた場合、故障・破壊の可能性がります。

Even if it is use within the maximum rating, continuous use on a high stress (high temperature and high superimposed voltage/large current drive, etc.) might spoil the product reliability.

最大定格内の使用であっても高負荷(高温および高電圧印加/大電流駆動etc.)での連続使用は製品の信頼性を低下させる恐れがあります。

3.2 Operating Conditions 動作条件

Table 3-2 Operating Conditions

Parameter	Symbol	Values			Unit	Note
		Min.	Typ.	Max.		
Operating Temperature	Top	-40	-	105	deg.C	
Magnetic Field Strength	Hext*	20	-	60	mT	
		16	-	48	kA/m	

* the applied horizontal magnetic field rotated above the sensor

3.3 Basic Characteristics 基本特性

Table 3-3 Basic Characteristics

Parameter	Symbol	Values			Unit	Note
		Min.	Typ.	Max.		
Each Element Resistance	Rel	8	10	12	kOhm	at Room Temp.
Bridge Resistance	Rtotal	4	5	6	kOhm	at Room Temp.
Temperature Coefficient of Bridge Resistance	TcR	-	-	1600	ppm/deg.C	-40 ~105deg.C
Temperature Coefficient of Change Rate of Magnetoresistance	TcΔR	-3900	-	-	ppm/deg.C	-40 ~105deg.C

3.4 Electric Characteristics 電気特性

Table 3-4 Electric Characteristics @25deg.C

Parameter	Symbol	Values			Unit	Note
		Min.	Typ.	Max.		
Offset Voltage	Voffset	-20	0	20	mV	(1)
Center Voltage	Vcenter	2.45	2.5	2.55	V	(2)
Peak to Peak Voltage	Vpeak	490	550	610	mVp-p	(3)
Phase Difference	Pdiff	87.5	90	92.5	deg.	(4)
Waveform Distortion	Wd	-	-	7	mV	(5)
Angular Accuracy	Δα	-	-	1.0	deg.	(6)

[note]

Unless otherwise specified, measurement condition is as follows.

VDD=5V, Hext=30mT, Top=25deg.C

特に注記ない限り、測定条件は下記の通り

VDD=5V, Hext=30mT, Top=25deg.C .

Definition of Parameter パラメータの定義

$$(1) \text{Voffset} = \frac{(+\sin \text{out max.}) + (+\sin \text{out min.})}{2} - \frac{(-\sin \text{out max.}) + (-\sin \text{out min.})}{2}$$

* The same calculation is applied to “+cos out” and “-cos out”.

$$(2) \text{Vcenter} = \frac{(+\sin \text{out max.}) + (+\sin \text{out min.})}{2}$$

* The same calculation is applied to “-sin out”, “+cos out” and “-cos out”.

$$(3) \text{Vpeak} = (+\sin \text{out max.}) - (+\sin \text{out min.}) + (-\sin \text{out max.}) - (-\sin \text{out min.})$$

* The same calculation is applied to “cos out”.

* Vpeak ratio is defined as ratio of Vpeak_sin and Vpeak_cos.

$$(4) \text{Pdiff} = \text{SinPhase} - \text{CosPhase}$$

* SinPhase: Phase of Vsin

* CosPhase: Phase of Vcos

* Vsin and Vcos are ideal curve.

$$(5) \text{Wd} = \text{Max.} | \text{Vmeas} - \text{Videal} |$$

* Vmeas: measured value

* Videal: ideal curve

$$(6) \Delta\alpha = \text{Max.} | \alpha_{\text{meas}} - \alpha_{\text{ideal}} |$$

* α_{meas} : calculated angle compensated offset, gain, and Pdiff.

* α_{ideal} : ideal angle calculated from Vsin and Vcos

* Vsin and Vcos are ideal curve.

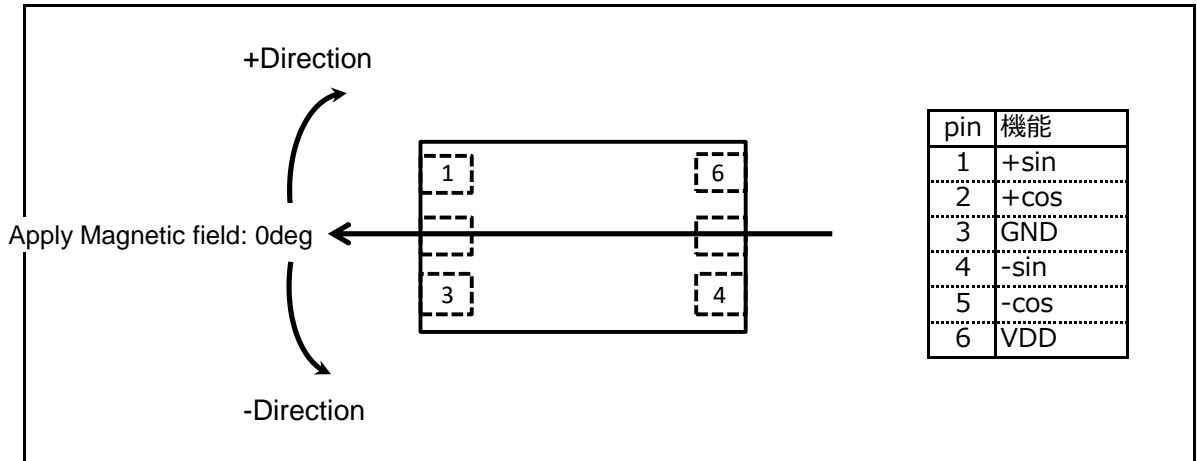

Figure 3-1 Definition of Magnetic Field Direction

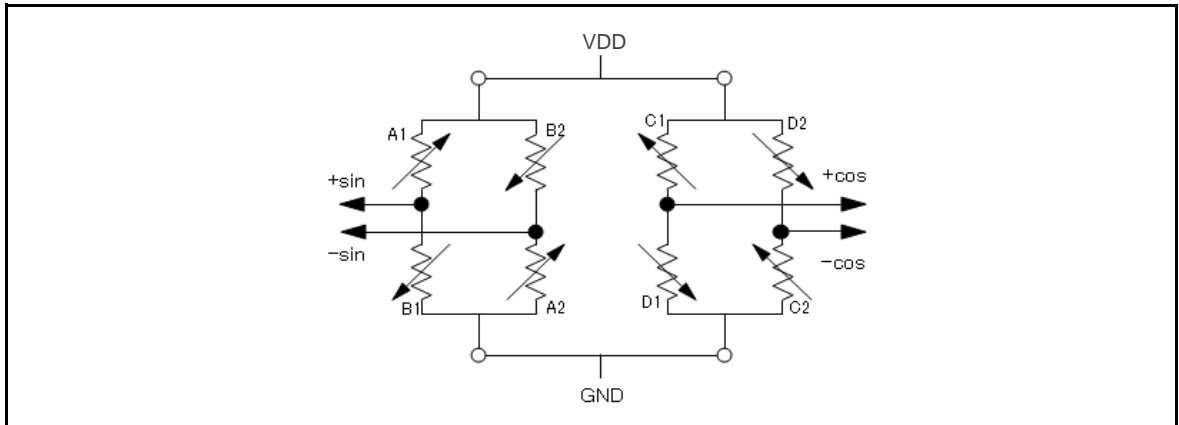

Figure 3-2 Equivalent Circuit

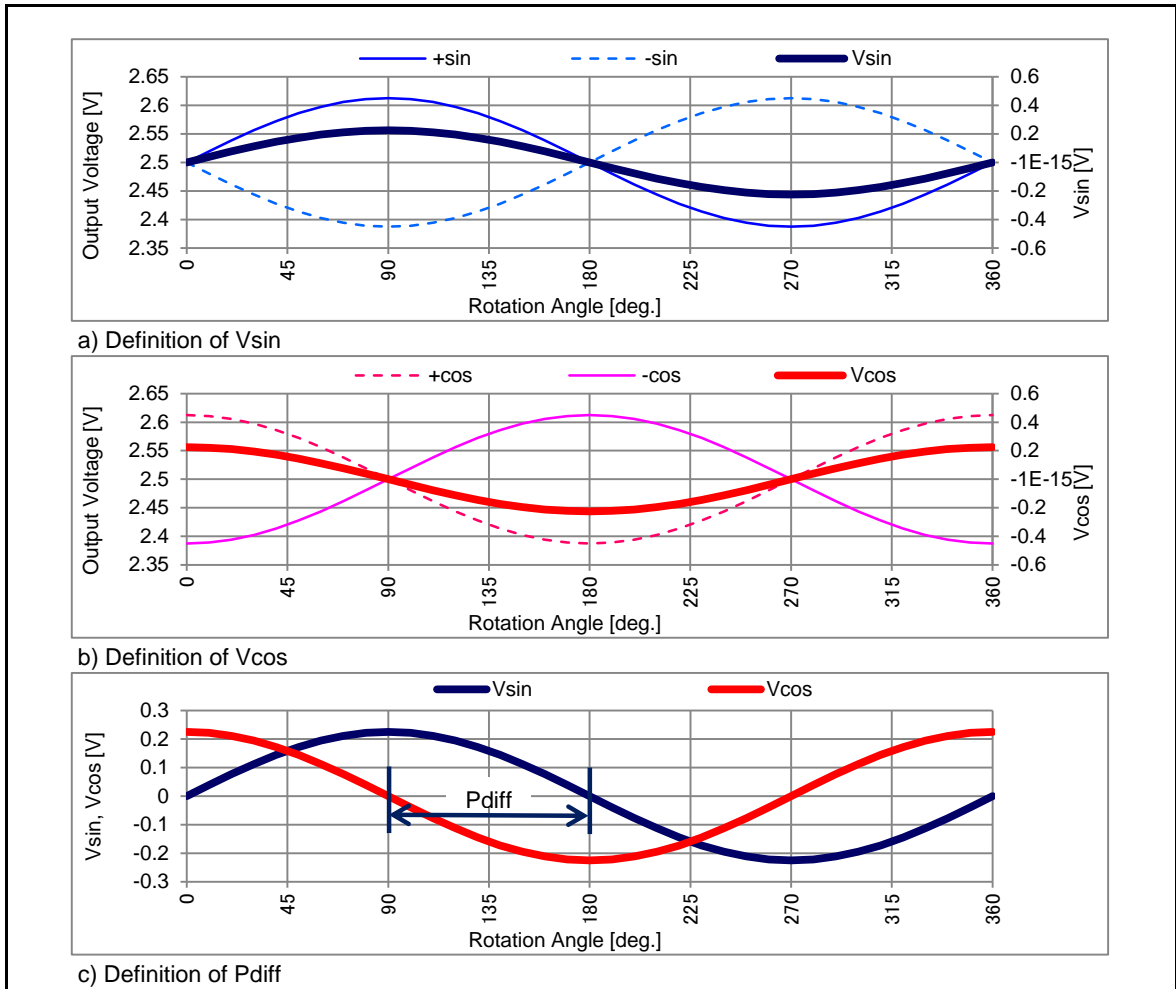

Figure 3-3 Definition of Vsin, Vcos, and Pdiff

4 Package Information パッケージ情報

4.1 Appearance 外観

The sensor shall be in good appearance, and have no functional failure or excessive damage such as rust, cracks, and split in any part.

各部の仕上げは良好で機能上有害な錆、傷、割れが有ってはならない。

4.2 Package Outline 外形図

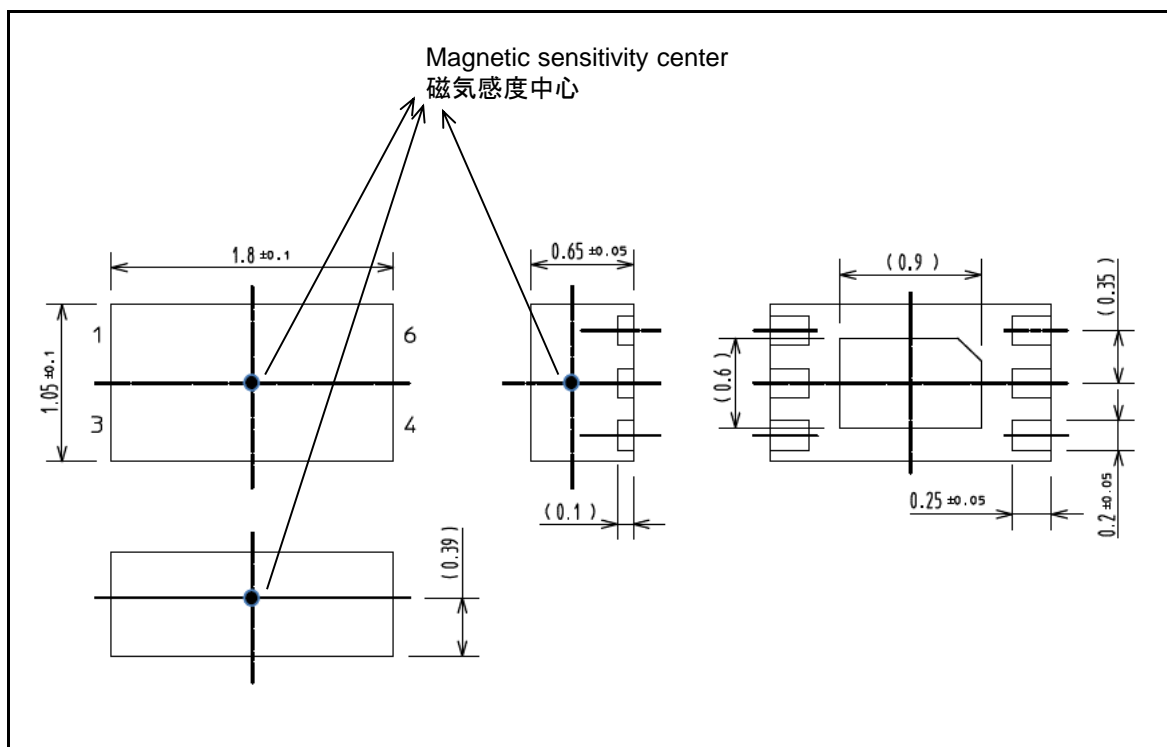

Figure 4-1 Package Outline (All dimensions in mm)

4.3 Footprint フットプリント

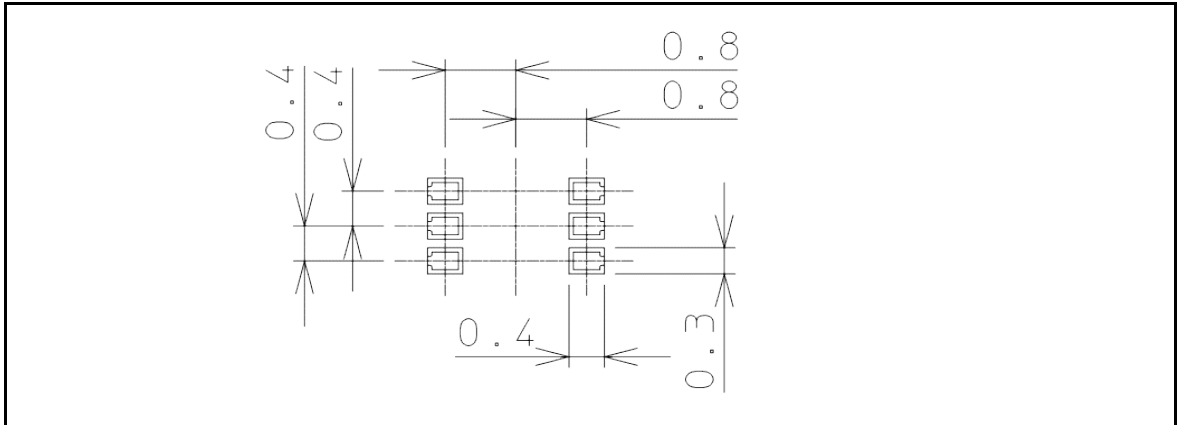

Figure 4-2 Recommended Footprint (Reference)

4.4 Package Marking 捺印

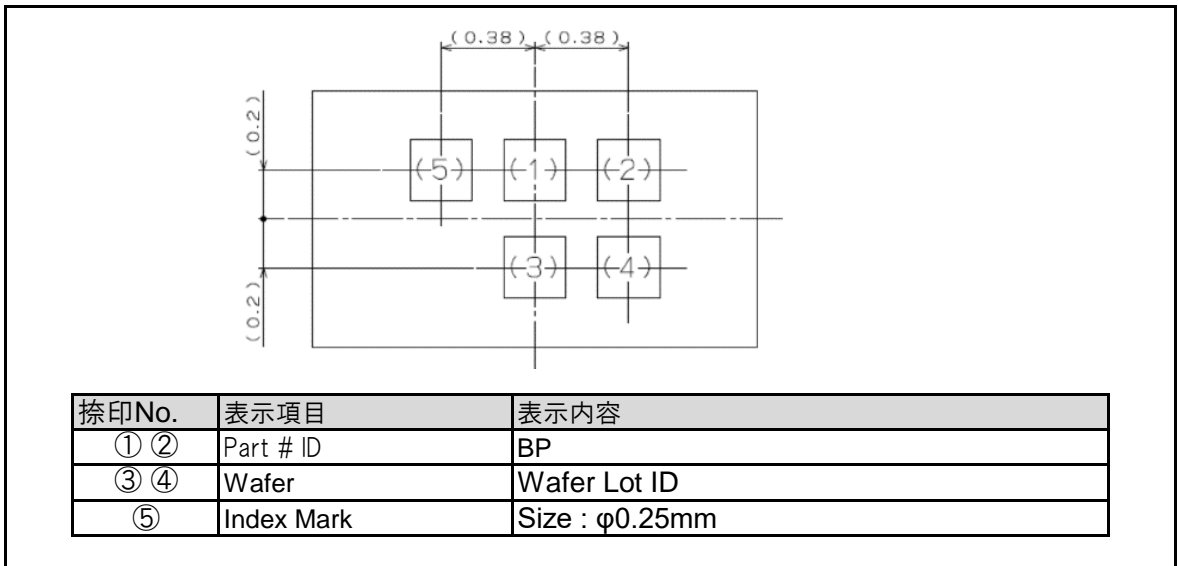

Figure 4-3 Marking of HGARAN008A

4.4 Structure 構造

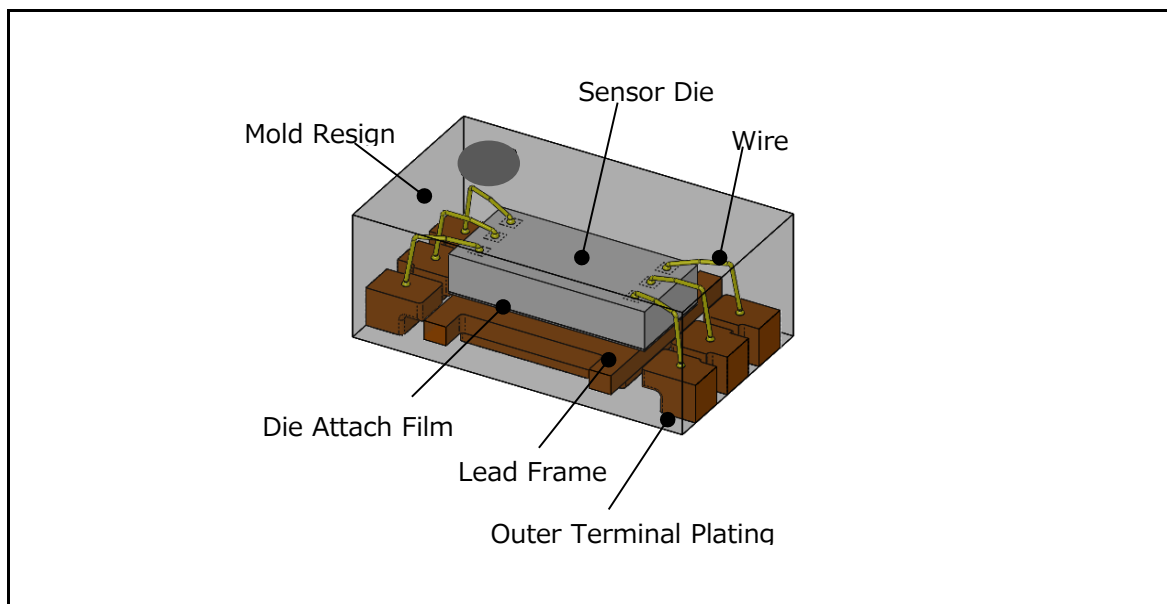

Figure 4-4 Internal Structure

Table 4-1 Components

Process	Parts Name	Materials
Die Mount	Sensor Chip	Si
	Die Attach Film	DAF tape
	Lead Frame	Cu, Pd-PPF
Wire Bonding	Wire	Au
Molding	Mold Resign	Epoxy Resign
Terminal Plating	Outer Terminal Plating	Pd-PPF

5 Packing Specifications 梱包仕様

5.1 Packing Information 梱包情報

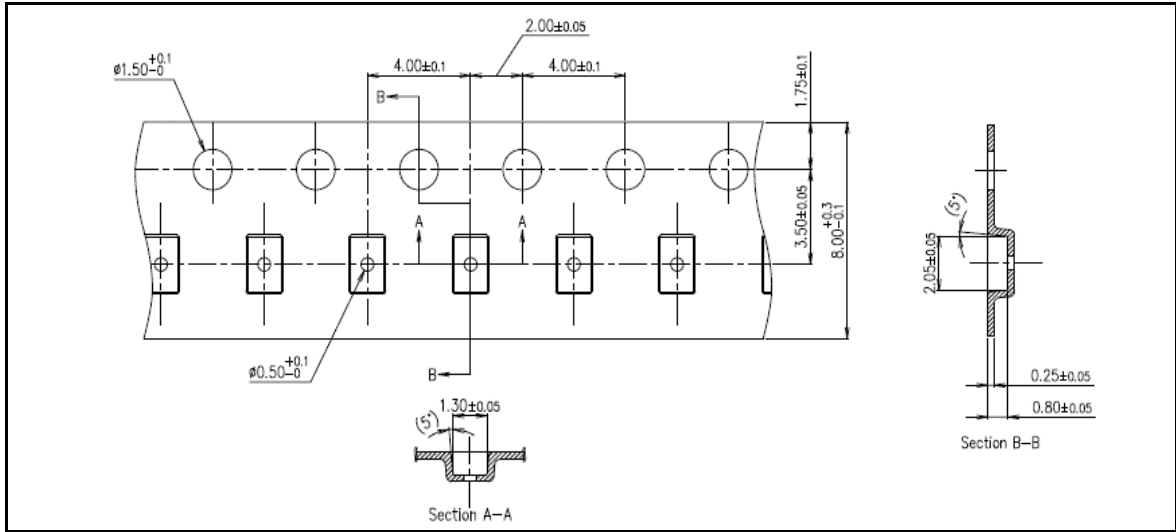

Figure 5-1 Emboss Tape Dimensions

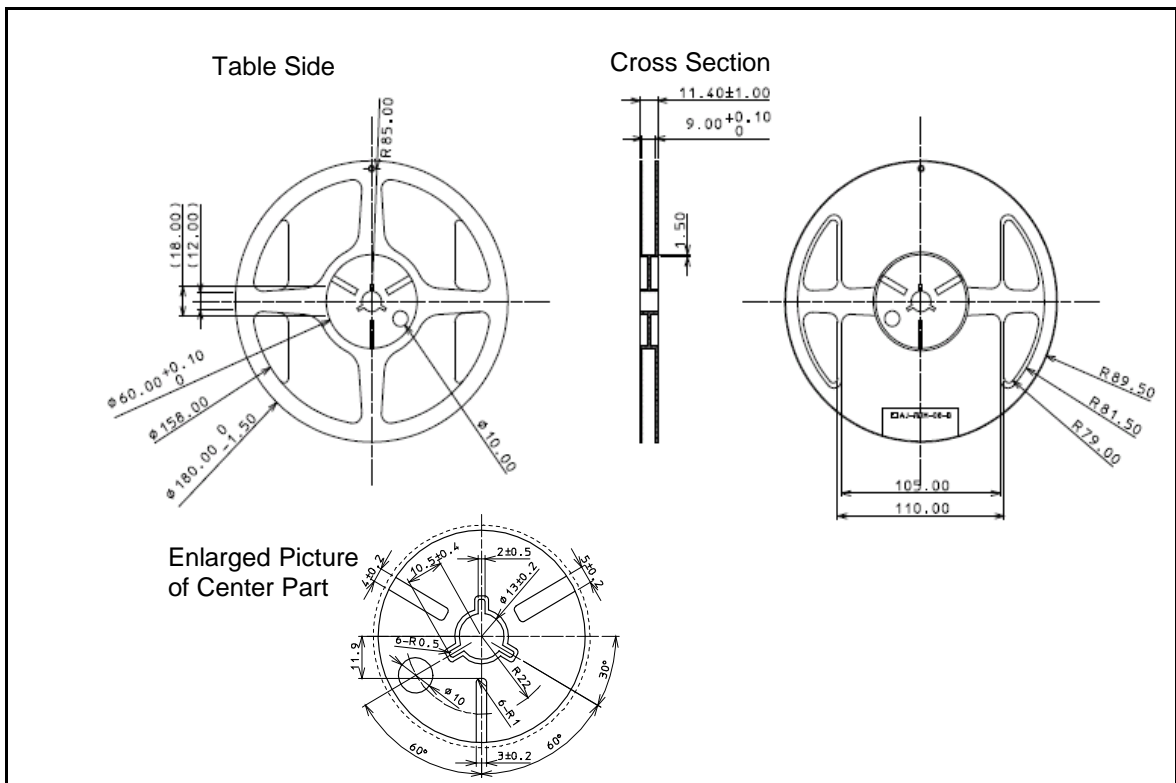

Figure 5-2 Reel Dimensions

5.2 Packing Specifications 梱包仕様

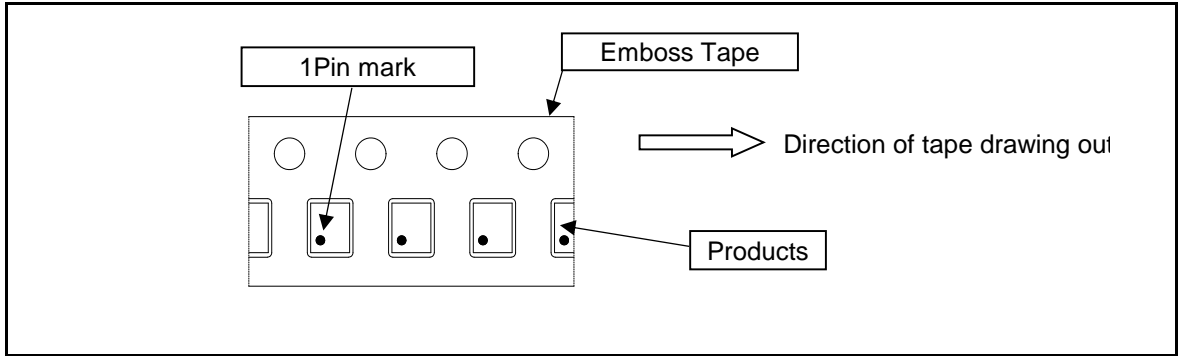

Figure 5-3 Orientation of Product Storing

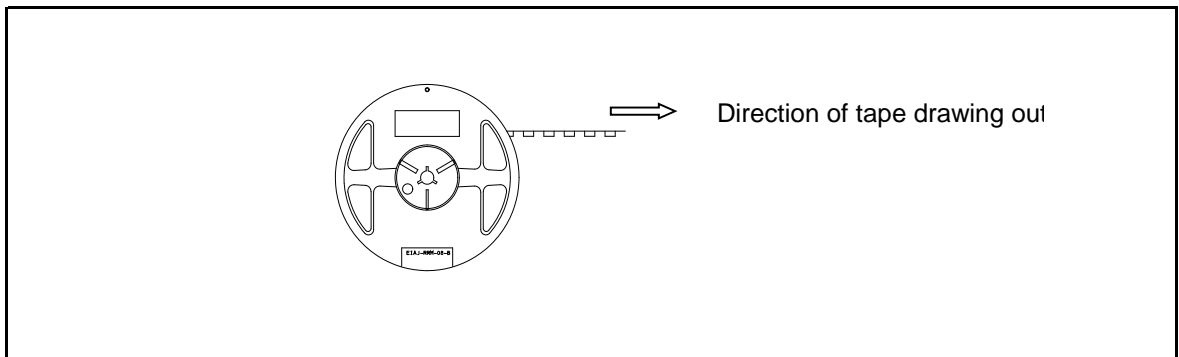

Figure 5-4 Feeding Direction

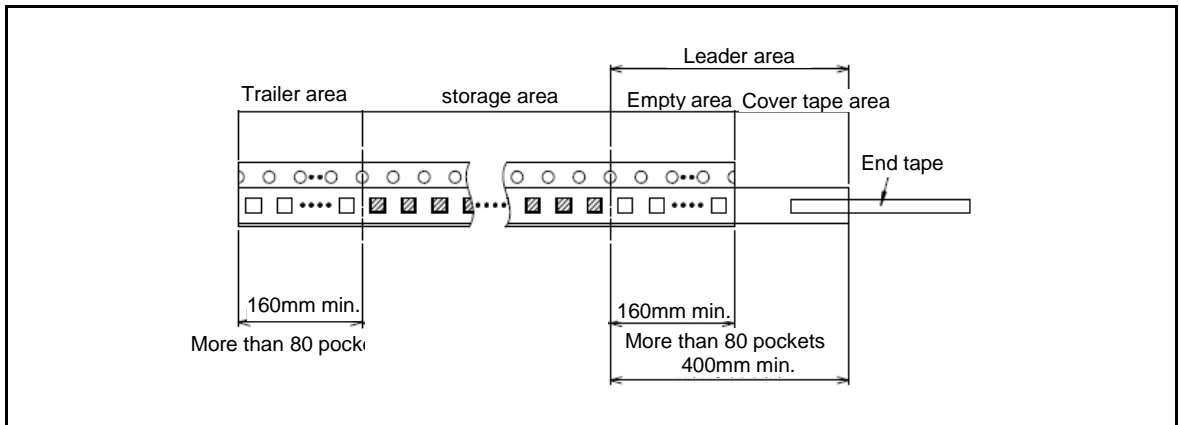

Figure 5-5 Taping Specification

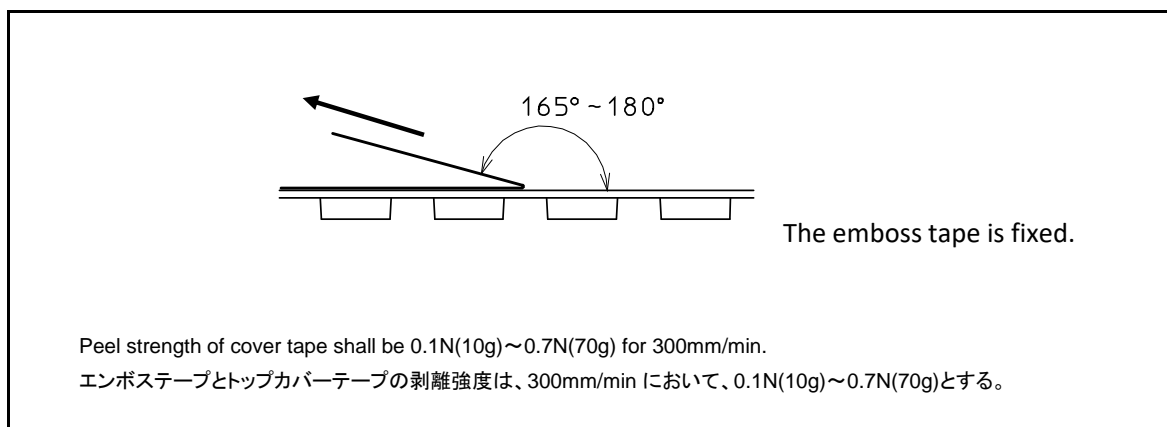

Figure 5-6 Peel Strength

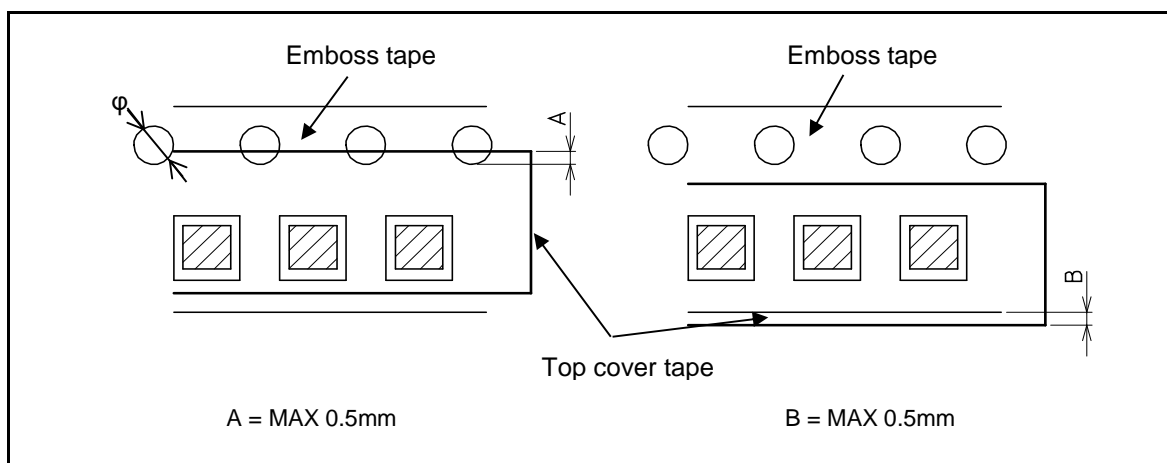

Figure 5-7 Top cover Tape Offset

6 Reliability Test Conditions 信頼性試験条件

6.1 Preconditioning for Reliability Test 信頼性試験の前処理

Baking [125°C×24Hr] + Moisture Absorption[85±5°C85±5%×168Hr] + Reflow 2times

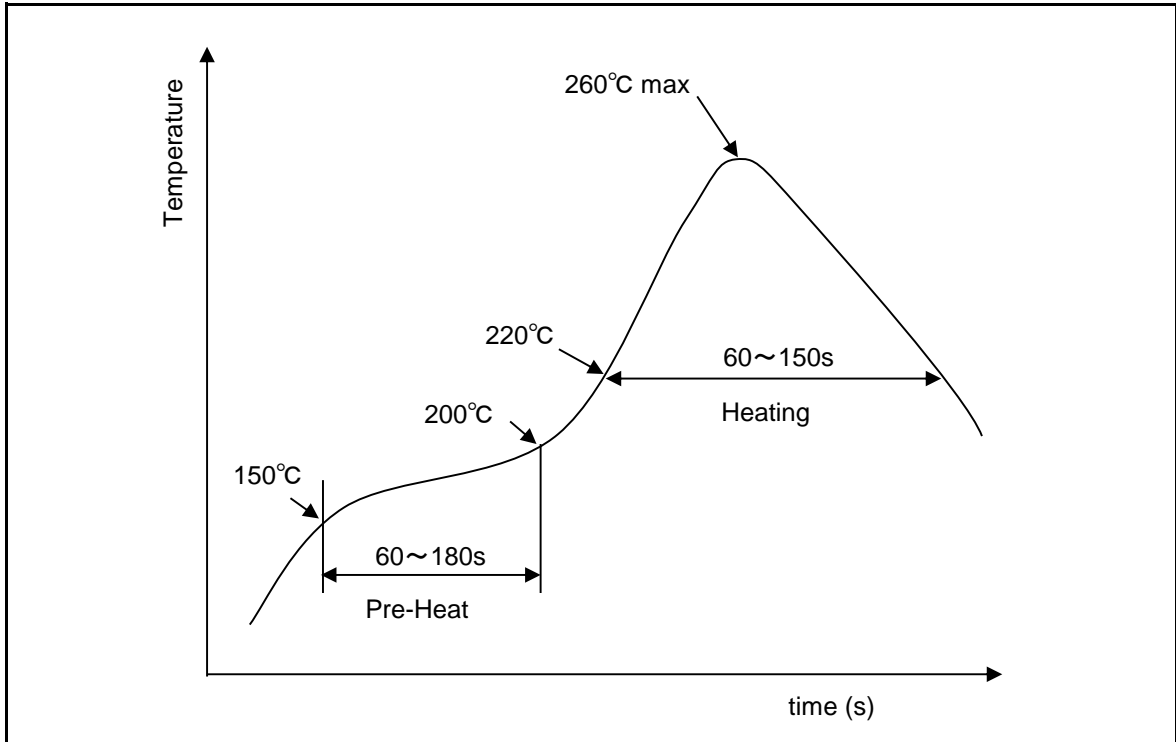

Figure 6-1 Reflow Profile for Pre-Conditioning

6.2 Reliability Test Items 信頼性試験項目

Table 6-1 Package Reliability Test Items

Test Items	Testing Methods / Conditions	Testing Time	Pre-Conditioning
Low Temp. Storage	-40±5deg.C	500Hr	N/A
High Temp. High Humidity Bias	+85±5deg.C, 85±5%RH, VDD=5±0.5V Bias	500Hr	Applied
High Temp. Bias	+105±5degC, VDD=5±0.5V Bias	500Hr	Applied
Thermal Cycle	1cycle: -40±3degC(30min)→+105±3degC(30min)	300cycle	Applied
ESD	±350V, 150pF, 330Ω, interval 10sec.	3 times per each terminal	N/A

7 Precautions When Handling Magnetic Sensor 製品お取り扱い時の注意

7.1 Storage Environment 保管環境

Products should be stored at an appropriate temperature and humidity (Recommended storage condition). Keep products away from chlorine and corrosive gas. There is a thing that influences product features when keeping it in an improper environment.

適切な温度・湿度環境(推奨保管条件)で保管していただけるようお願いいたします。また、塩素や腐食性のあるガスも避けるようお願いします。不適切な環境で保管した場合は、製品特性に影響する事があります。

7.2 Long-term Storage 長期保管

Long-term storage may result in poor lead solder ability and degraded electrical performance even under proper conditions. For those part that stored more than 1 year, solder ability should be checked before use. For storage longer than 1 year, it is recommended to store in nitrogen atmosphere. Oxygen in atmosphere oxidant leads of products and lead solder ability get worse.

適切な保管環境でも長期に保管した場合は、リード端子の半田付け性が悪くなったり、電気特性が不良になる場合がありますので、長期保管した場合は、半田付け性や電気特性をご確認の上、ご使用下さい。保管が長期(1年以上)に及ぶ場合は、窒素雰囲気中での保管をお勧めします。大気中で保管されますと、大気中の酸素により素子のリード部分が酸化され、リード端子の半田付け性が悪くなります。

7.3 ESD 静電気ESD

This products does NOT have built in ESD protect circuit, so it may break if over ESD applied to this circuit. Please take measure for ESD when handle the products. Conducted container is recommended for product conveyance and packing instead of plastic container. Please connect ground line and use non high voltage leakage, when using soldering iron or external measurement circuit.

本製品は静電気保護回路を内蔵していません。その能力を超える静電気が加わった場合には破壊されることがありますので、製品を取り扱う場合には十分な静電気対策を実施してください。包装・運搬容器はプラスチック製を極力避け、導電容器をご使用ください。また製品のハンドリングについても充分に考慮してください。(リストストラップの使用等)はんだごてや測定回路などは高電圧リークのないものを、必ずアースを取ってご使用ください。

7.4 External Magnetic Field 外乱磁場

This sensor has detects the direction of the magnetic field that the installed magnet on the measurement device makes. Therefore, please note that an external magnetic field in the system environment influences the angle detection of the sensor. (see Figure 7-1)

本製品は、被測定物に取付けた磁石が作る磁界の方向を検出しています。従って、使用環境における外部磁界が、センサの角度検出に影響を及ぼしますので、ご注意ください。(Figure 7-1参照)

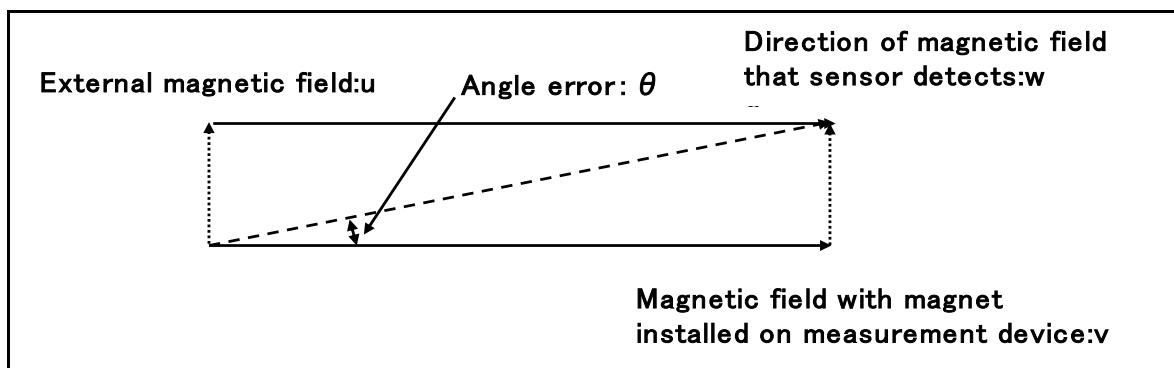

Figure 7-1 Influence on Detection Angle by External Magnetic Field

Appendix
A1 List of Figures 図のリスト

Figure 1-1	Image of HGARAN008A in the DFN Package	3
Figure 2-1	Pin Configuration	4
Figure 3-1	Definition of Magnetic Field Direction	8
Figure 3-2	Equivalent Circuit	8
Figure 3-3	Definition of V_{sin} , V_{cos} , and P_{diff}	9
Figure 4-1	Package Outline (All dimensions in mm)	10
Figure 4-2	Recommended Footprint (Reference)	11
Figure 4-3	Marking of HGARAN008A	11
Figure 4-4	Internal Structure	12
Figure 5-1	Emboss Tape Dimensions	13
Figure 5-2	Reel Dimensions	13
Figure 5-3	Orientation of Product Storing	14
Figure 5-4	Feeding Direction	14
Figure 5-5	Taping Specification	14
Figure 5-6	Peel Strength	15
Figure 5-7	Top cover Tape Offset	15
Figure 6-1	Reflow Profile for Pre-Conditioning	16
Figure 7-1	Influence on Detection Angle by External Magnetic Field	17

A2 List of Tables 表のリスト

Table 2-1	Pin Description	4
Table 3-1	Absolute Maximum Rating Parameters	5
Table 3-2	Operating Conditions	5
Table 3-3	Basic Characteristics	6
Table 3-4	Electric Characteristics @25deg.C	6
Table 4-1	Components	12
Table 6-1	Package Reliability Test Items	16

Appendix

A3 Document Revision History 改定履歴

Revision	Date	Description
01	Jun.13, 2017	First release
02	Nov.22, 2017	Revised Figure 4-3, Figure 4-4, Table 4-1, Figure 5-1, Figure 5-2 Figure 5-3, Figure 5-4, Figure 5-5, Figure 5-7