

Part number description :

10134330-XXXLF

- ▶ LF: Lead Free, RoHs compliant, see note
- ▶ XXX : Color ref or/and version

PN	Colour	Version
10134330-001LF	grey	(A)
10134330-002LF	blue	(A)
10134330-003LF	yellow-green	(A)

TECHNICAL DATA / DIMENSIONS

Dimensions	
Width mm	31.0
Length mm	84.0
Height mm	49.0
Mounting type (EN 60715)	Omega TH35
Panel mounting	M5 screw
Technical data	
Maximum load current	Cu 320A Al 290A
Insulating material	PA
Self-extinguishing degree acc. to UL94	V2
Nominal Voltage	690V
Nominal Current	320A
Connection data	
Conductor cross-section solid min/max	25 / 150 mm <sup>2</sup>
Stripping length	max 20 mm
Screw – recessed Allen screw	M16 – SW6
Tightening torque: 25-35 mm <sup>2</sup>	14 Nm
Tightening torque: 70-120 mm <sup>2</sup>	25 Nm
Tightening torque: 150 mm <sup>2</sup>	30 Nm

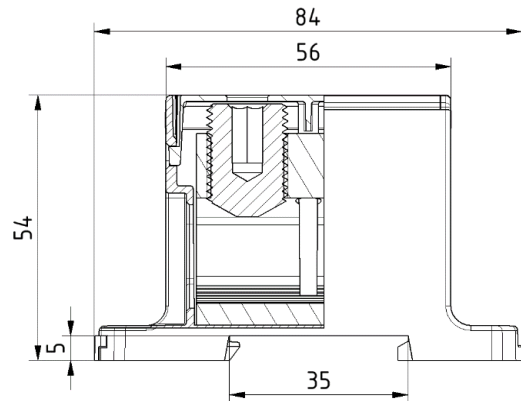
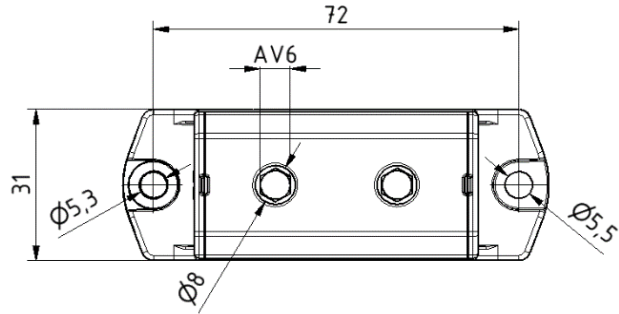

APPROVALS

EN60947-7-1  
690V – Cu 320A / Al 290A

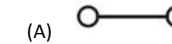

Note : THIS PRODUCT MEETS EUROPEAN UNION DIRECTIVES AND OTHER COUNTRY REGULATIONS AS PER GS-47-0004

ACCESSORIES

Item	Description
<b>DIN RAIL system - Mounting and Installation material</b>	
10134392-001LF	Steel Omega Rail TH35x7,5mm -2mt length
10134393-001LF	Slotted Steel Omega Rail TH35x7,5mm -2mt length
10134394-001LF	Steel Omega Rail TH35x15mm -2mt length
10134395-001LF	Slotted Steel Omega Rail TH35x15mm -2mt length
10134387-001LF	Angled support bracket
10134389-001LF	End Bracket for TH35 Omega rail -Width 9mm
10134390-001LF	End Bracket for TH35 Omega rail -Width 6mm

spec ref	dr	Aymeric Soudy	29-06-2015	projection	size	A3	scale	size out of scale
tolerance std	eng	Aymeric Soudy	29-06-2015		mm	ecn no	rel level	rev
ISO 406 ISO 1101	chr							
surface ✓ ISO 1302	appr	Aymeric Soudy	29-06-2015	product family	DIN Terminal Block			dwg no 10134330
	linear	0.X	± 0.3	SCREW Terminal block		A		
		0.XX	± 0.1	Higt current 150				
		0.XXX	± 0.05	www.fcicon				
	angular	0°	± 2°	cat. no.	- Product customer drawing		sheet 1 of 1	