

AVERY DENNISON MARKETING SPECIFICATION

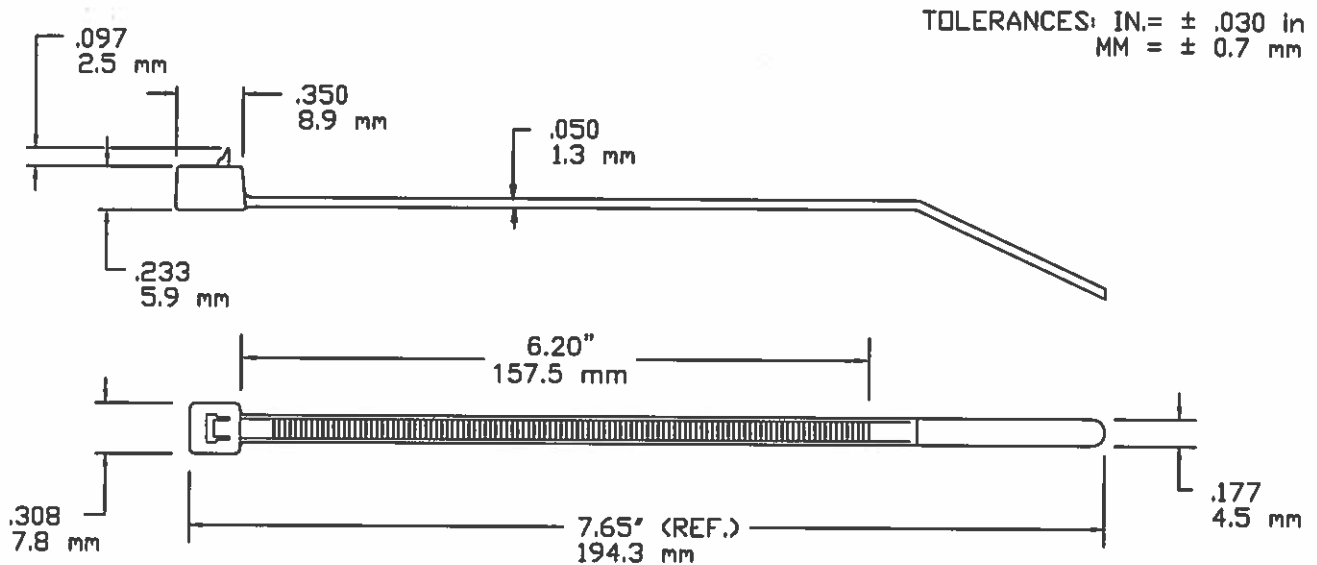

TOLERANCES: IN. = ± .030 in
MM = ± 0.7 mm

NOT TO SCALE

LOOP TENSILE STRENGTH:	50 LBF / 220N MIN. PER AS-23190
OPERATING TEMPERATURE:	-40°F (-40°C) TO 185°F (85°C)
MIN. INSTALLATION TEMP:	32°F (0°C)
MATERIAL:	NYLON 6/6
WEIGHT:	.04838 oz. / 1.42 grams
BUNDLE DIAMETER:	Ø0.063"/1.59mm TO Ø1.75"/44mm
PACKAGED IN:	100/BAG, 5000/CASE

NOTE: THESE CABLE TIES ARE PLENUM RATED AND HAVE A FLAMMABILITY RATING OF V2.



FASTENER DIVISION
FITCHBURG, MA 01420 U.S.A.
TEL. 1-800-225-5913
MA. 978-353-8157



**E57800
TYPE11**

DESCRIPTION:

7.5" / 190mm CABLE TIE, RELEASABLE
NATURAL

APPROVAL:

J. Boyle 9/18/2015

STOCK NO.

10364-0

REV

B