

PAD PRINTED INDICATOR LINE (0.020 WIDE) IN-WHITE.
 Ⓟ

SECTION A-A

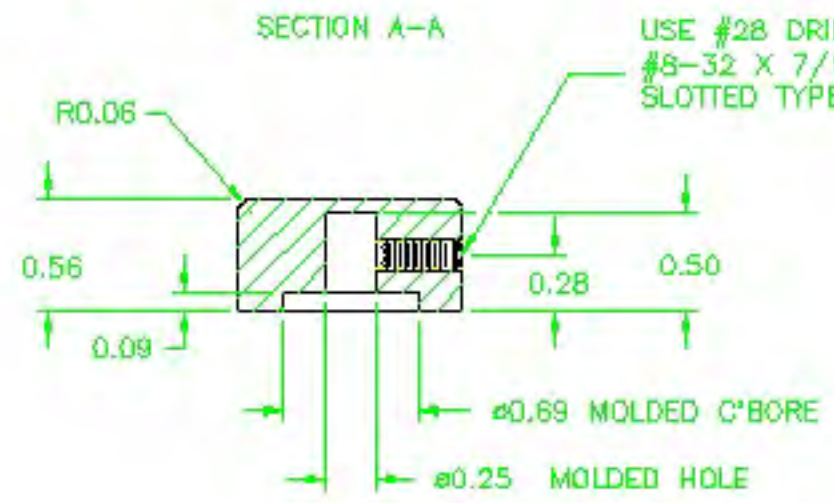

USE #28 DRILL (0.140), #8-32 TAP, #8-32 X 7/16 LG. CUP POINTED, SLOTTED TYPE, SET SCREW 10022.

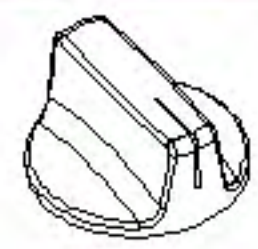

NOT TO SCALE/ FOR REFERENCE

MATERIAL: #2311 PLENCO PHENDLIC (B11)
 COLOR: BLACK

Ⓐ

| | | | | | |
|--|----------------------------------|---|---------------------------|----|---------|
| TOLERANCES: UNLESS OTHERWISE SPECIFIED | DO NOT SCALE DRAWING | | | | |
| DECIMALS: X.XXX ± .005 X.XX ± .015 | MM: X.XX ± 0.15MM X.X ± 0.4MM | B | DELETED "FLEED" FROM NAME | RF | 7/31/02 |
| FRACTIONS ± 1/64 | ANG. ± 1' | - | UPDATED/140 TOOLBOOK | ST | 4/25/01 |
| | | A | ADDED NEW TOOL BRUSH | HD | 2/24/98 |
| CHANGES | | | | | |