

REVISIONS					
P.	LTN	DESCRIPTION	DATE	DMN	APVD
P	REV PER ECO	17-012106	8-22-17	CT	DM

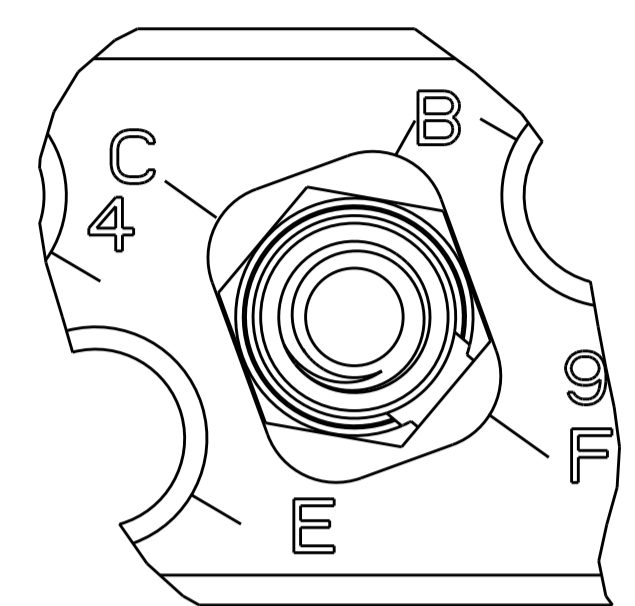

JACKSCREW POLARIZATION "F" SHOWN
SCALE 4:1

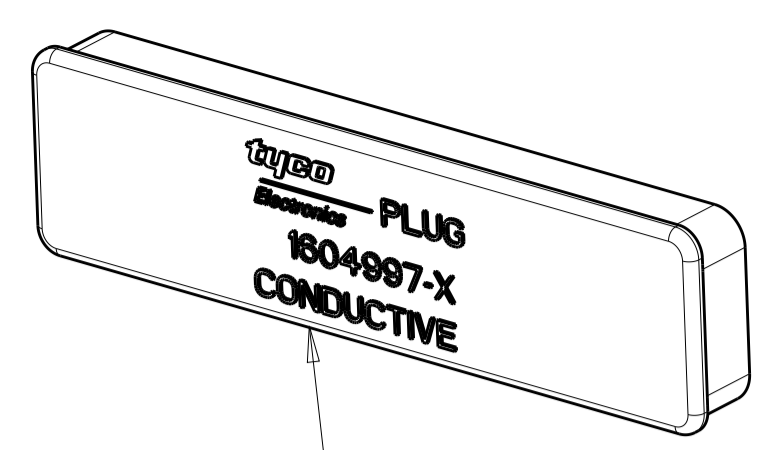
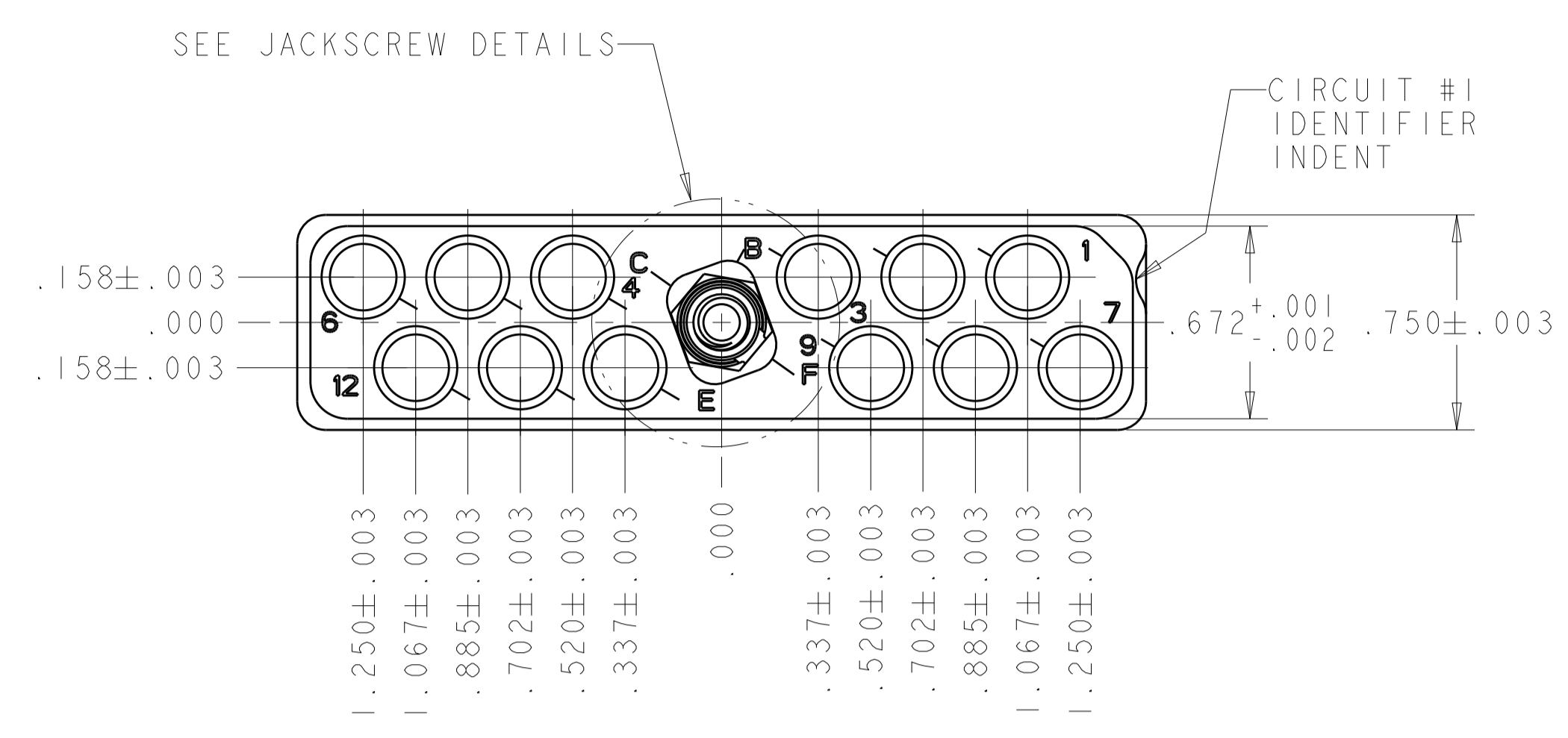
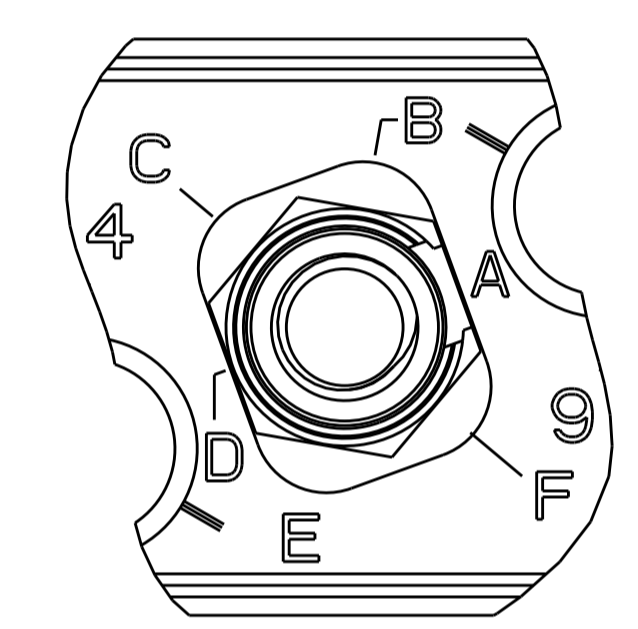
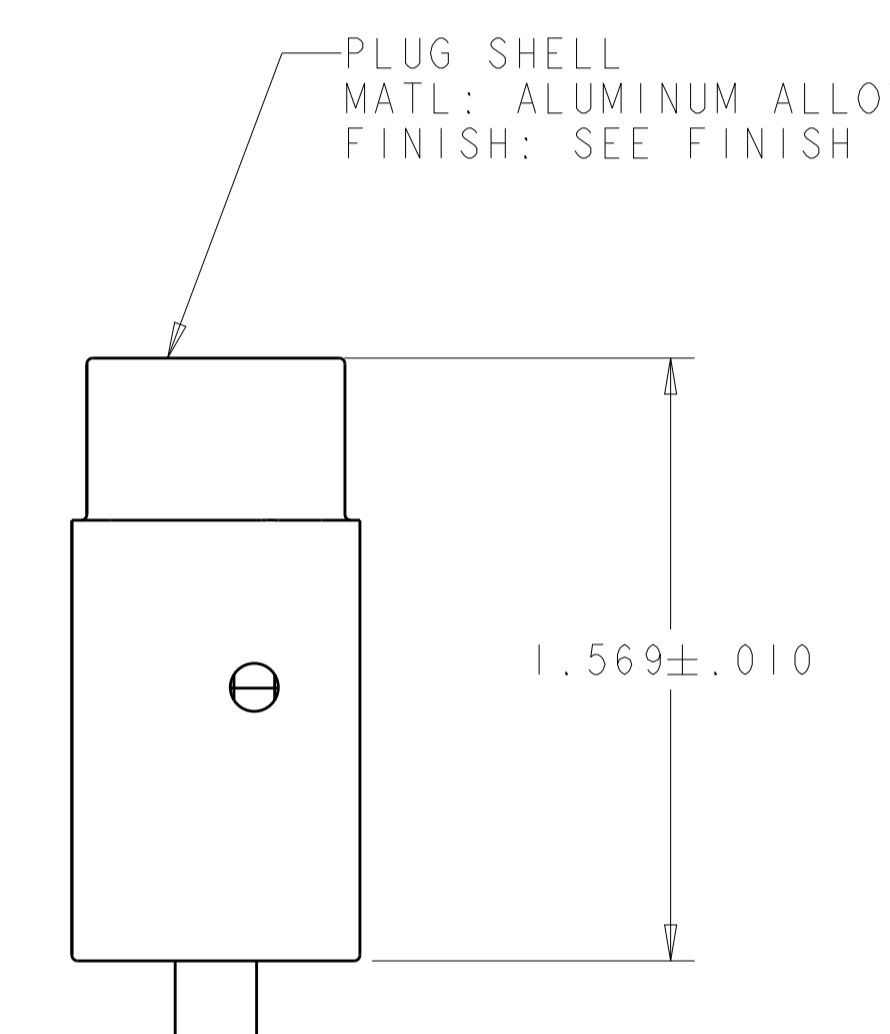
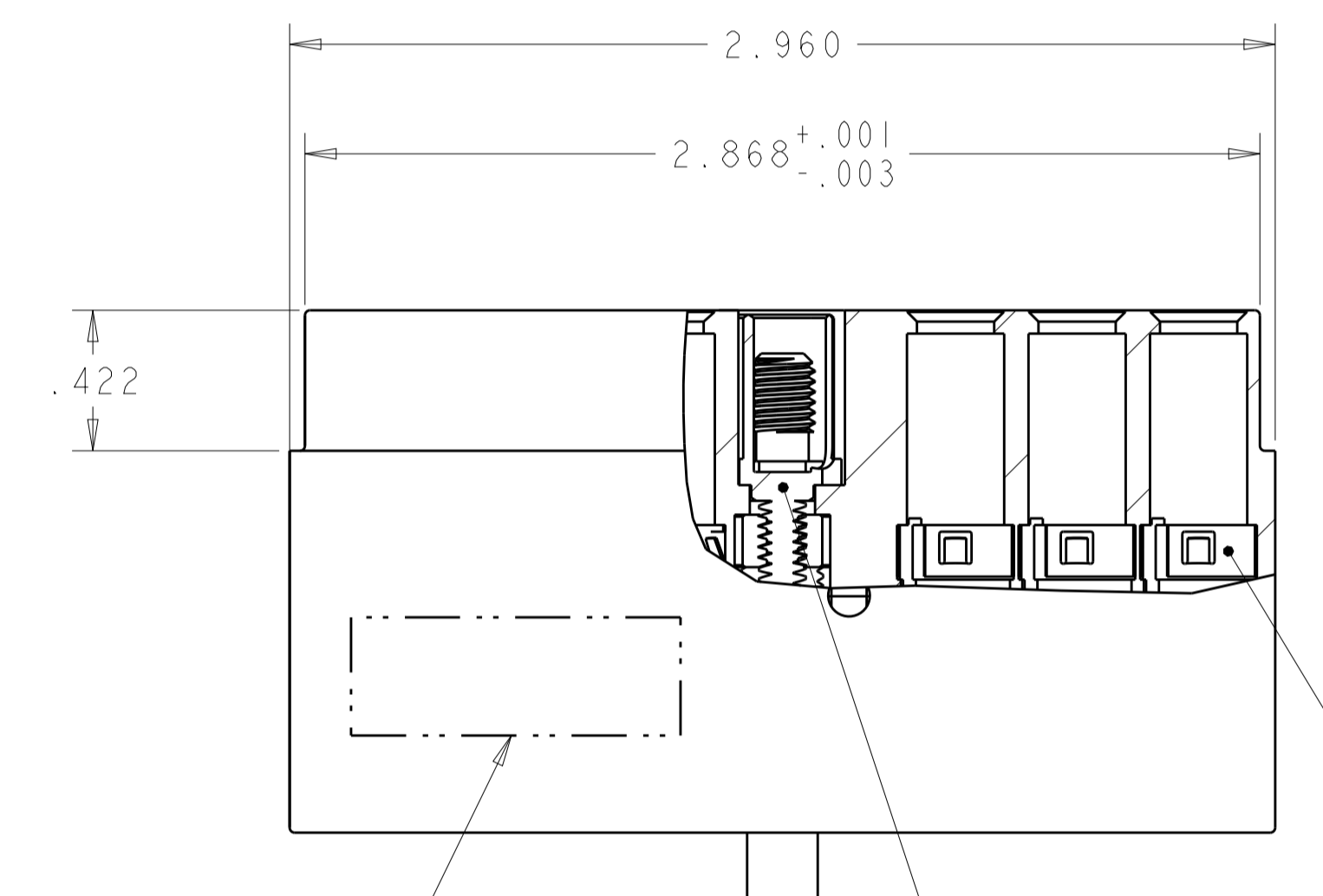

JACKSCREW POLARIZATION "A" SHOWN
SCALE 4:1

TE LOGO, DATE CODE AND EITHER CUSTOMER OR TE PART NUMBER (PER TABLE), CAGE CODE 00779 (-6 ONLY) MARKED APPROX AS SHOWN ON NEAR OR FAR SIDE)

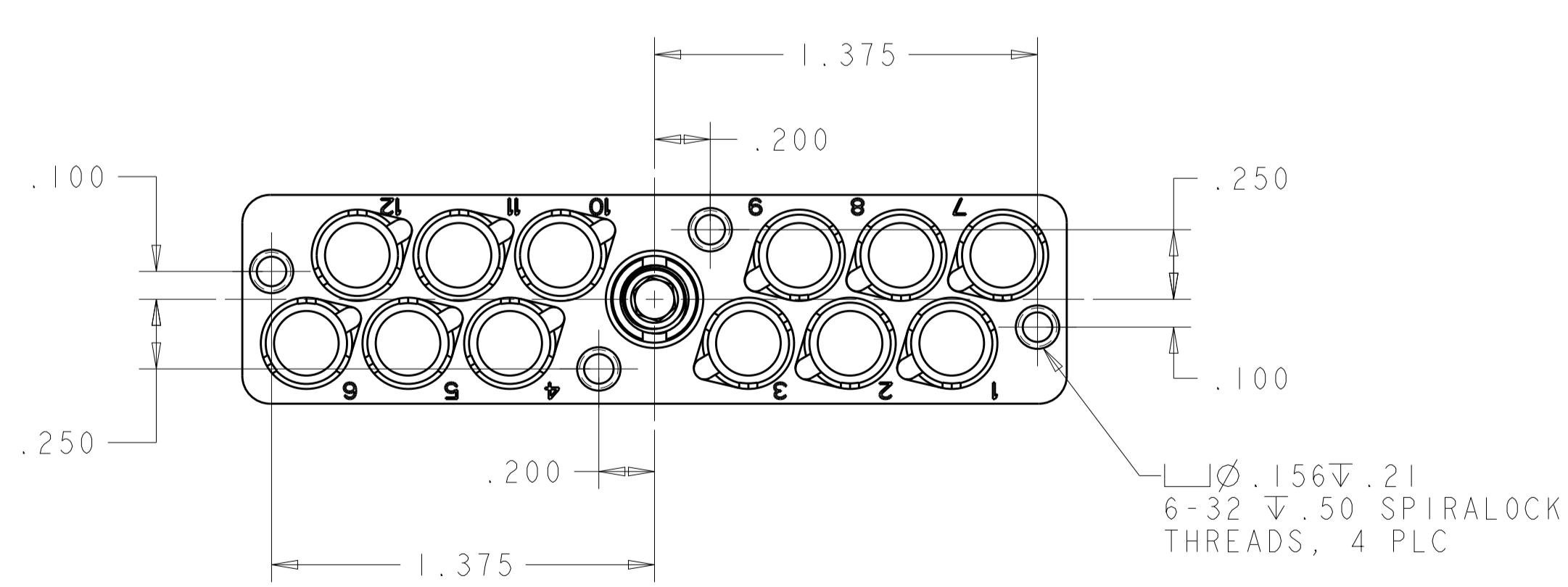

ELECTROLESS NICKEL	1445693-4	BACC65BC12ND	JACKSCREW ASSEMBLED PLZN CODE D	1-1604800-5
ELECTROLESS NICKEL	1445693-4	BACC65BC12N	WITH JACKSCREW-RETENTION NUT KIT	1-1604800-4
ELECTROLESS NICKEL	1445693-4	BACC65BC12NE	JACKSCREW ASSEMBLED PLZN CODE E	1-1604800-3
ELECTROLESS NICKEL	1445693-4	BACC65BC12NC	JACKSCREW ASSEMBLED PLZN CODE C	1-1604800-2
ELECTROLESS NICKEL	1445693-4	BACC65BC12NB	JACKSCREW ASSEMBLED PLZN CODE B	1-1604800-1
ELECTROLESS NICKEL	1445693-4	BACC65BC12NF	JACKSCREW ASSEMBLED PLZN CODE F	1-1604800-0
ELECTROLESS NICKEL	1445693-4	BACC65BC12NA	JACKSCREW ASSEMBLED PLZN CODE A	1604800-9
ELECTROLESS NICKEL	1445693-3	---	WITH JACKSCREW-RETENTION NUT KIT	1604800-8
ELECTROLESS NICKEL	1445693-3	---	JACKSCREW ASSEMBLED PLZN CODE A	1604800-6
ELECTROLESS NICKEL	1445693-3	---	WITH JACKSCREW-RETENTION NUT KIT	1604800-5
OBSELETE BLACK ANODIZED	1445693-4	BACC65BC12A	WITH JACKSCREW-RETENTION NUT KIT	1604800-4
SHELL FINISH	RECOMMENDED CONTACT WITH WIRE SEAL	BOEING PART NUMBER	DESCRIPTION	PART NO.

SUPERSEDED BY 1604800-5

WITH JACKSCREW-RETENTION NUT KIT IS UNASSEMBLED TO CONNECTOR ASSY. KIT IS PACKAGED IN SEALED BAG.

THIS DRAWING IS A CONTROLLED DOCUMENT. DWN: Brent D. Toth 24 JUNE 2004
 CHK: W.H. BERNHART 24 JUNE 2004
 APVD: W.H. BERNHART 24 JUNE 2004

STE TE Connectivity

NAME: PLUG ASSEMBLY, QUADRAX, FREE HANGING, RR/RR, 12 POSITION

SIZE: A1 CAGE CODE: 00779 DRAWING NO: 1604800

SCALE: 2:1 SHEET 1 OF 1 REV P