

E-15

Incremental Encoder



FEATURES

- 3 or 6 pulses per revolution (standard).
- SMD or Through-hole Mount.
- Working Temperature Range (-40°C to +120°C).
- Low Profile (4.4 mm).
- Embossed Tape (SMD) or Bulk packaging (Through hole).
- Reflow Soldering capability.
- Shaft insertable from both sides.
- Polarised "T" rotor (European Home Appliance standard).
- All PT/ PTC 15 shafts compatible.
- IP54 protection according to IEC 60529.

STANDARD SPECIFICATIONS

Closed Contact Resistance:	< 5Ω
Open Contact Resistance:	> 10MΩ
Contact Current:	10μA – 100mA
Operating Voltage:	16 VDC (3 pulse) 13.5±0.2 VDC (6 pulse)
Number of pulses	3 or 6
Mechanical Life:	36K cycles (3 pulse) 10K (6 pulse)
Rotational Torque:	<2Ncm
Mechanical rotation angle:	360° (endless)
Temperature Range:	-40°C to +120°C

TYPICAL APPLICATIONS

The N-15 potentiometer/sensor series has been expanded to incorporate both encoders and rotary switches in the same package configuration allowing the user to design in any one of the three options whilst keeping the same board layout and user interface. The extended temperature range (-40°C to +120°C) allows the encoder to be employed in extreme environmental applications where other encoders currently on the market can not be used. This in combination with optional SMD or through-hole mounting makes the E-15 series ideal for Automotive Heating, Ventilation & Air conditioning, Oven & Microwave (White and Brown goods in general), Kitchen Appliance and Power Tool Controls.

GRAPH CODE

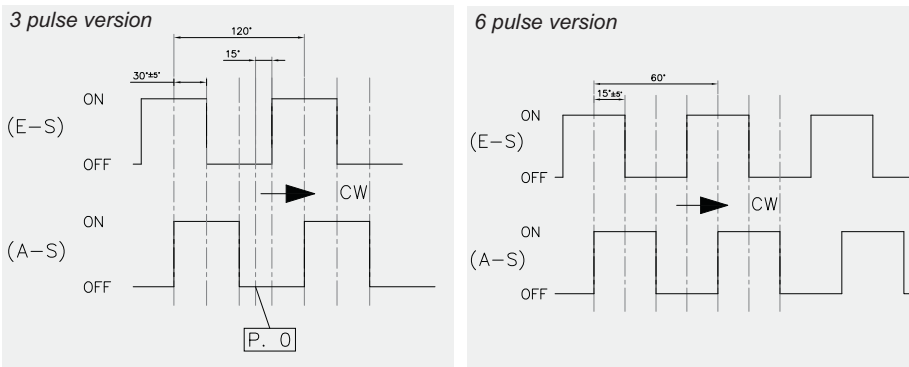

TERMINAL DESIGNATIONS

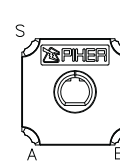

Viewed from mounting side

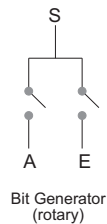

Bit Generator (rotary)

HOW TO ORDER

E15	T	S	-	03
Series	Rotors	Mounting Method		Pulses
E-15	T	V = Through Hole S = SMD H = Horizontal Adjust		03 06

(See note 1)

NOTES:

(1) Horizontal adjust versions will be studied case by case

Shafts are not available mounted to the encoder and should be ordered separately

Please note that the features and specifications of custom products are to be used as general guidelines only

E-15 T S + DRAWING NUMBER (Max. 16 digits)

This way of ordering should be used for options which are not included in the "How to order" standard and optional extras.

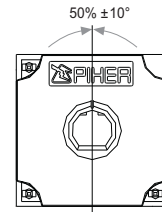

SMD VERSION

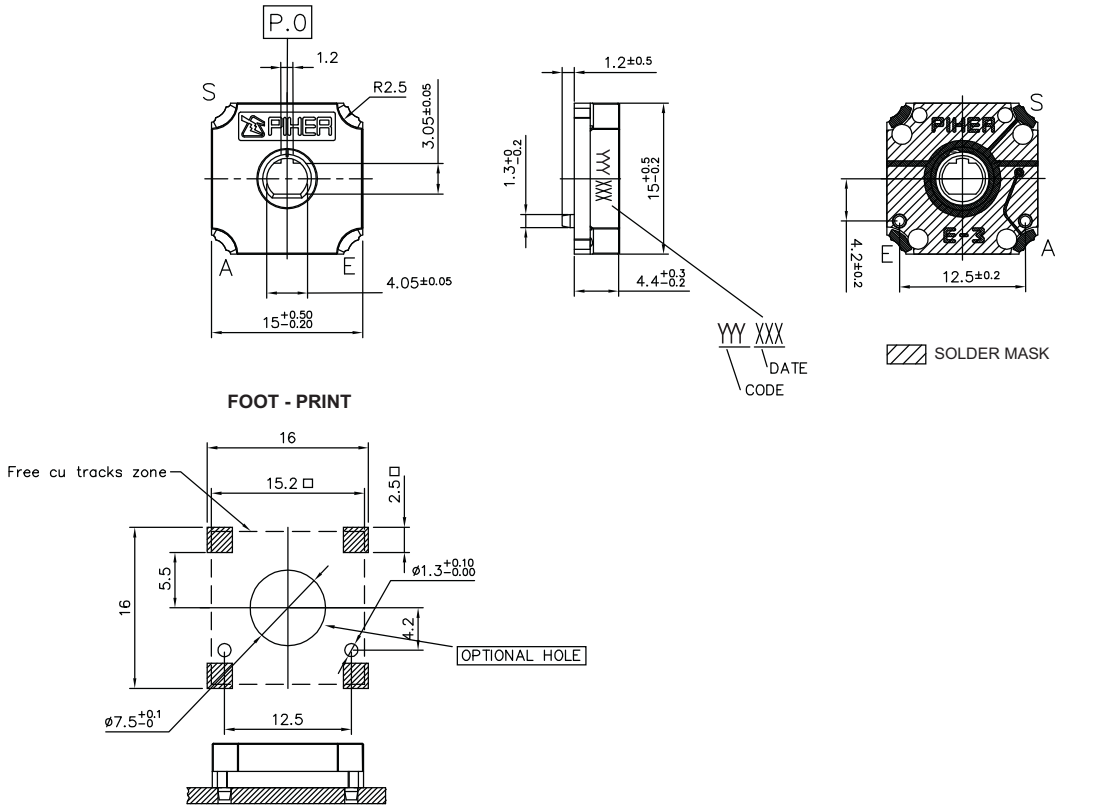

THROUGH HOLE VERSION

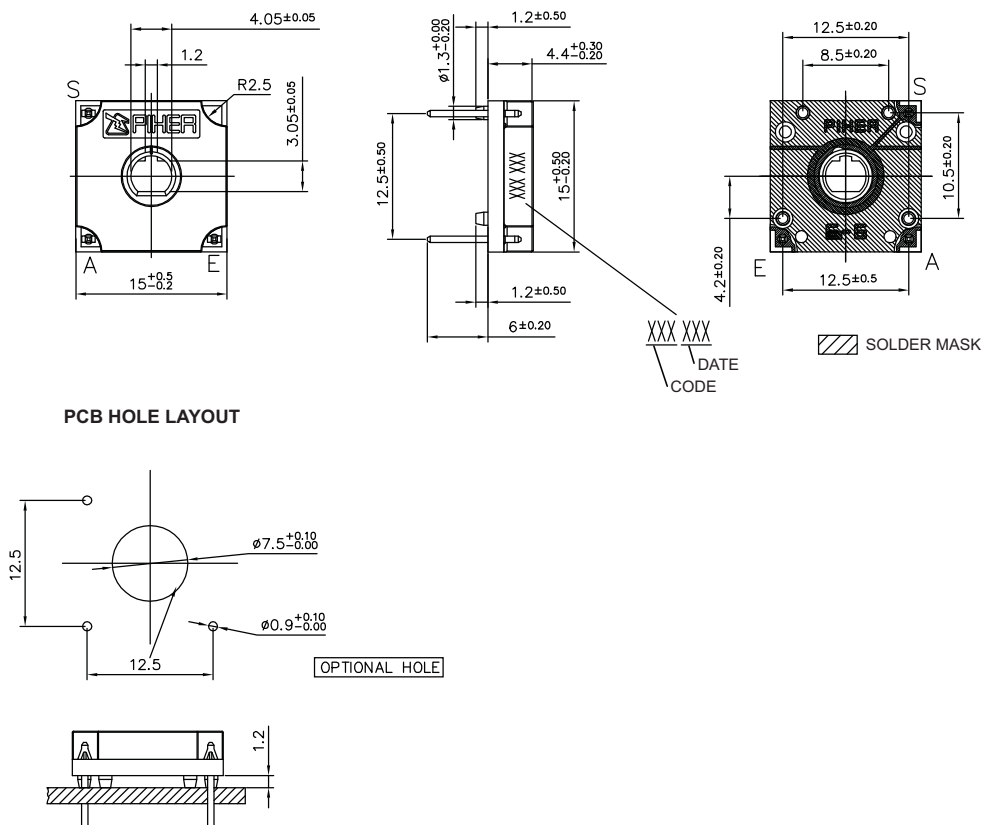

HORIZONTAL ADJUST - VERTICAL MOUNT

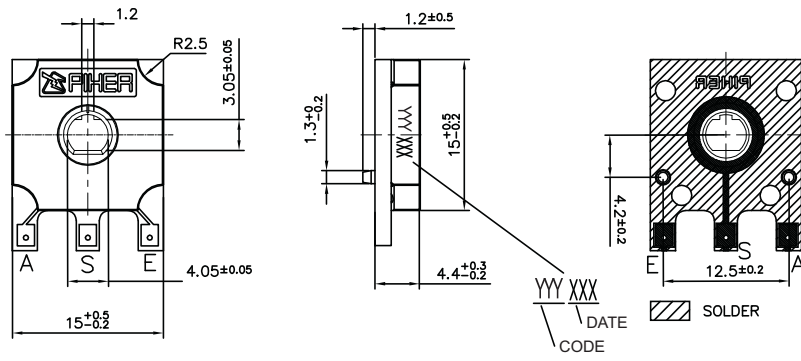

PACKAGING

BULK

150 Units per box.
Through hole version only

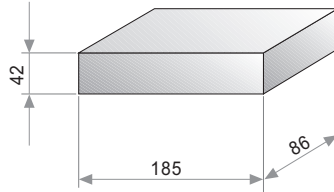

TAPE ON REEL

500 Units per reel.
SMD type only.

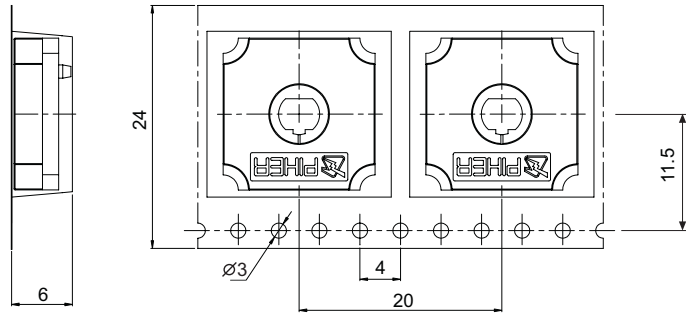
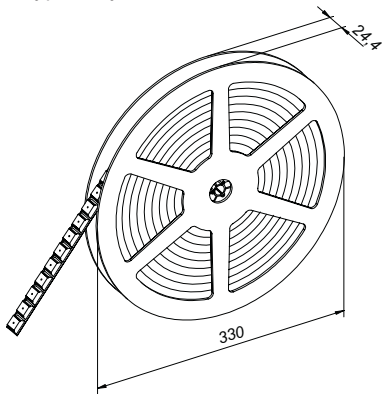

TEST CIRCUIT DIAGRAM

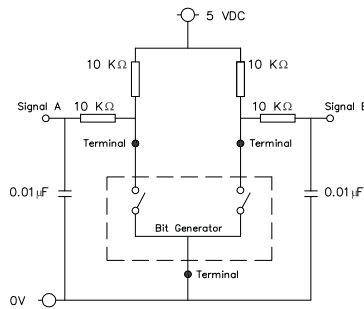

RECOMMENDED REFLOW PROFILE (SMD types)

SnPb Reflow Profile

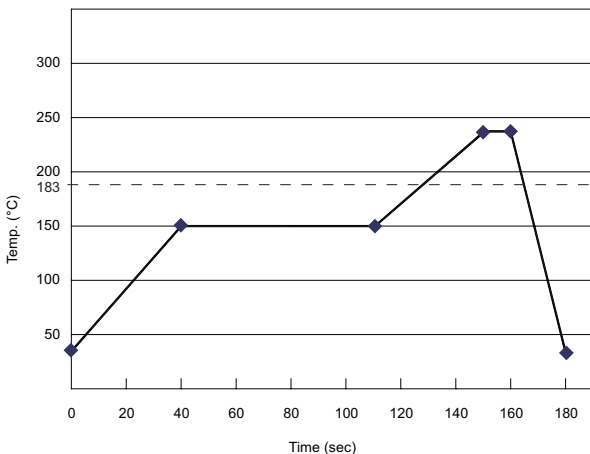

Lead Free Reflow Profile

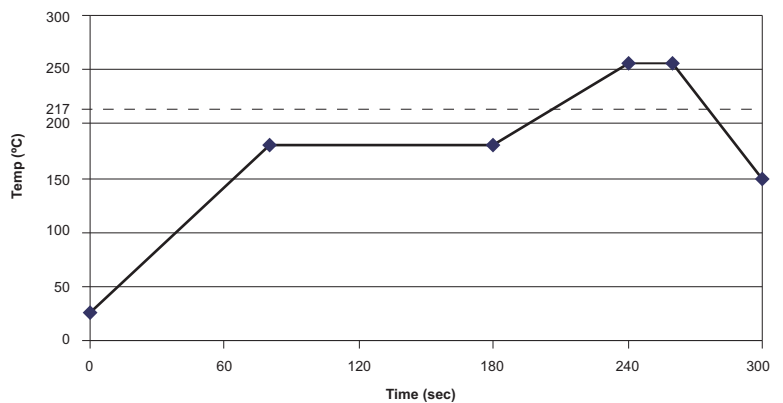

The recommended reflow profile is provided as a guideline. Optimal profile may differ due to oven type, assembly layout or other design or process variables. Customers should verify actual device performance in their specific application and reflow process. Please contact Piher if you require additional support.

Disclaimer

The product information in this catalogue is for reference purposes. Please consult for the most up to date and accurate design information.

Piher Sensors & Controls S.A., its affiliates, agents, and employees, and all persons acting on its or their behalf (collectively, "Piher"), disclaim any and all liability for any errors, inaccuracies or incompleteness contained herein or in any other disclosure relating to any product described herein.

Piher disclaims any and all liability arising out of the use or application of any product described herein or of any information provided herein to the maximum extent permitted by law. The product specifications do not expand or otherwise modify Piher's terms and conditions of sale, including but not limited to the warranty expressed therein, which apply to these products.

No licence, express or implied, by estoppel or otherwise, to any intellectual property rights is granted by this document or by any conduct of Piher.

The products shown herein are not designed for use in medical, life-saving, or life-sustaining applications unless otherwise expressly indicated. Customers using or selling Piher products not expressly indicated for use in such applications do so entirely at their own risk and agree to fully indemnify Piher for any damages arising or resulting from such use or sale. Please contact authorised Piher personnel to obtain written terms and conditions regarding products designed for such applications.

Product names and markings noted herein may be trademarks of their respective owners.

Information contained in and/or attached to this catalogue may be subject to export control regulations of the European Community, USA, or other countries. Each recipient of this document is responsible to ensure that usage and/or transfer of any information contained in this document complies with all relevant export control regulations. If you are in any doubt about the export control restrictions that apply to this information, please contact the sender immediately. For any Piher Sensors & Controls Exports, Note: All products / technologies are EAR99 Classified commodities. Exports from the United States are in accordance with the Export Administration Regulations. Diversion contrary to US law is prohibited.

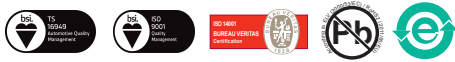

All Piher products can be adapted to meet customer's requirements.
Please always use the latest updated datasheets published at our website www.piher.net.